

49 CFR Part 195 - Transportation of Hazardous Liquids by Pipeline



Provided by **ViaData LP**
Publishers of **WinDOT™ The Pipeline Safety Encyclopedia**

History: Current through Amendment 195-107 of April 29, 2024
Authority: 30 U.S.C. 185(w)(3), 49 U.S.C. 5103, 60101 et seq., and 49 CFR 1.97.
Source: Amdt. 195-22, 46 FR 38360, July 27, 1981, unless otherwise noted.

CAUTION ! Printed copies eventually become out of date. Refer to this code part at www.49CFRPipeline.com to verify that you have the latest version.

To view all the federal pipeline safety codes in 49 CFR, go to www.49cfrpipeline.com.

For full versions of the pipeline safety codes, including amendments, interpretations, special permits, alert notices advisory bulletins and much more go to www.windot.com.

To receive up to date information on important pipeline safety issues, subscribe to our free Rapid Update Service at <https://www.viadata.com/contact>.

Disclaimer: The WinDOT package is based on documentation originating at the US Department of Transportation. While every effort has been made to maintain accuracy with respect to the original documentation, the user should base any final judgment or actions on current Department of Transportation documents.

Table of Contents

SubPart A - General (§§0-15)	1
SubPart A - General.....	1
§195.0 Scope.....	1
§195.1 Which pipelines are covered by this Part?.....	1
§195.2 Definitions.....	3
§195.3 What documents are incorporated by reference partly or wholly in this part?.....	6
§195.4 Compatibility necessary for transportation of hazardous liquids or carbon dioxide.	9
§195.5 Conversion to service subject to this part.	10
§195.6 Unusually Sensitive Areas (USAs).....	10
§195.8 Transportation of hazardous liquid or carbon dioxide in pipelines constructed with other than steel pipe.....	14
§195.9 Outer continental shelf pipelines.....	14
§195.11 What is a regulated rural gathering line and what requirements apply?.....	14
§195.10 Responsibility of operator for compliance with this part.	16
§195.12 What requirements apply to low-stress pipelines in rural areas?.....	16
§195.13 What requirements apply to pipelines transporting hazardous liquids by gravity?.....	19
§195.15 What requirements apply to reporting-regulated-only gathering lines?	20
§195.18 How to notify PHMSA.	20
SubPart B - Annual, Accident, and Safety-Related Condition Reporting (§§48-65).....	21
SubPart B - Annual, Accident, and Safety-Related Condition Reporting	21
§195.48 Scope.....	21
§195.49 Annual report.....	21
§195.50 Reporting accidents.	21
§195.52 Immediate notice of certain accidents.	22
§195.54 Accident reports.....	23
§195.55 Reporting safety-related conditions.	23
§195.56 Filing safety-related condition reports.	24
§195.57 Removed	24
§195.58 Report submission requirements.....	24
§195.59 Abandonment or deactivation of facilities.	25
§195.60 Operator assistance in investigation.....	26
§195.61 National Pipeline Mapping System.	26
§195.62 [Removed].....	26
§195.63 OMB control number assigned to information collection	27
§195.64 National Registry of Operators.	27
§195.65 Safety data sheets.	28
Subpart C - Design Requirements (§§100-134)	29
SubPart C - Design Requirements	29
§195.100 Scope.....	29
§195.101 Qualifying metallic components other than pipe.	29
§195.102 Design temperature.	30
§195.104 Variations in pressure.	30
§195.106 Internal design pressure.	30
§195.108 External pressure.	32
§195.110 External loads.....	32

§195.111 Fracture propagation.....	32
§195.112 New pipe.....	32
§195.114 Used pipe.....	33
§195.116 Valves.....	33
§195.118 Fittings.....	34
§195.120 Passage of internal inspection devices.....	34
§195.122 Fabricated branch connections.....	35
§195.124 Closures.....	35
§195.126 Flange connection.....	35
§195.128 Station piping.....	35
§195.130 Fabricated assemblies.....	35
§195.132 Design and construction of aboveground breakout tanks.....	35
§195.134 Leak detection.....	36
SubPart D - Construction (§§200-266).....	37
SubPart D - Construction.....	37
§195.200 Scope.....	37
§195.202 Compliance with specifications or standards.....	37
§195.204 Inspection-general.....	38
§195.205 Repair, alteration and reconstruction of aboveground breakout tanks that have been in service.....	38
§195.206 Material inspection.....	38
§195.207 Transportation of pipe.....	38
§195.208 Welding of supports and braces.....	39
§195.210 Pipeline location.....	39
§195.212 Bending of pipe.....	39
§195.214 Welding procedures.....	40
§195.216 Welding: Miter joints.....	40
§195.218 [Removed].....	40
§195.220 [Removed].....	40
§195.222 Welders and welding operators: Qualification of welders and welding operators.....	40
§195.224 Welding: Weather.....	41
§195.226 Welding: Arc burns.....	41
§195.228 Welds and welding inspection: Standards of acceptability.....	41
§195.230 Welds: Repair or removal of defects.....	41
§195.232 [Removed].....	42
§195.234 Welds: Nondestructive testing.....	42
§195.236 [Removed].....	42
§195.238 [Removed].....	43
§195.242 [Removed].....	43
§195.244 [Removed].....	43
§195.246 Installation of pipe in a ditch.....	43
§195.248 Cover over buried pipeline.....	43
§195.250 Clearance between pipe and underground structures.....	44
§195.252 Backfilling.....	44
§195.254 Above ground components.....	44
§195.256 Crossing of railroads and highways.....	45
§195.258 Valves: General.....	45

§195.260 Valves: Location.....	46
§195.262 Pumping equipment.....	47
§195.254 Above ground components.....	48
§195.264 Impoundment, protection against entry, normal/emergency venting or pressure/vacuum relief for aboveground breakout tanks.....	48
§195.266 Construction records.....	49
SubPart E - Pressure Testing (§§300-310).....	50
SubPart E - Pressure Testing.....	50
§195.300 Scope.....	50
§195.302 General requirements.....	50
§195.303 Risk-based alternative to pressure testing older hazardous liquid and carbon dioxide pipelines.....	51
§195.304 Test pressure.....	53
§195.305 Testing of components.....	53
§195.306 Test medium.....	53
§195.307 Pressure testing aboveground breakout tanks.....	54
§195.308 Testing of tie-ins.....	54
§195.310 Records.....	55
SubPart F - Operation and Maintenance (§§400-454).....	56
SubPart F -Operation and Maintenance.....	56
§195.400 Scope.....	56
§195.401 General requirements.....	57
§195.402 Procedural manual for operations, maintenance, and emergencies.....	57
§195.403 Emergency response training.....	61
§195.404 Maps and records.....	62
§195.405 Protection against ignitions and safe access/egress involving floating roofs.....	63
§195.406 Maximum operating pressure.....	63
§195.408 Communications.....	64
§195.410 Line markers.....	64
§195.412 Inspection of rights-of-way and crossings under navigable waters.....	65
§195.413 Underwater inspection and reburial of pipelines in the Gulf of Mexico and its inlets.....	65
§195.414 Inspections of pipelines in areas affected by extreme weather and natural disasters.....	66
§195.416 Pipeline assessments.....	66
§195.417 Notification of potential rupture.....	68
§195.418 Valves: Onshore valve shut-off for rupture mitigation.....	68
§195.419 Valve capabilities.....	70
§195.420 Valve maintenance.....	71
§195.422 Pipeline repairs.....	73
§195.424 Pipe movement.....	73
§195.426 Scraper and sphere facilities.....	74
§195.428 Overpressure safety devices and overflow protection systems.....	74
§195.430 Firefighting equipment.....	74
§195.432 Inspection of in-service breakout tanks.....	75
§195.434 Signs.....	75
§195.436 Security of facilities.....	76
§195.438 Smoking or open flames.....	76
§195.440 Public awareness.....	76

§195.442 Damage prevention program.....	77
§195.444 Leak detection.....	78
§195.446 Control room management.	78
§195.450 Definitions.....	81
§195.452 Pipeline integrity management in high consequence areas.....	82
§195.454 Integrity assessments for certain underwater hazardous liquid pipeline facilities located in high consequence areas.....	91
Subpart G - Qualification of Pipeline Personnel (§§501-509).....	92
Subpart G - Qualification of Pipeline Personnel	92
§195.501 Scope.....	92
§195.503 Definitions.....	92
§195.505 Qualification program.....	93
§195.507 Recordkeeping.....	93
§195.509 General.....	94
SubPart H - Corrosion Control (§§551-591).....	95
SubPart H - Corrosion Control.....	95
§195.551 What do the regulations in this subpart cover?	95
§195.553 What special definitions apply to this subpart?	95
§195.555 What are the qualifications for supervisors?.....	96
§195.557 Which pipelines must have coating for external corrosion control?.....	96
§195.559 What coating material may I use for external corrosion control?.....	96
§195.561 When must I inspect pipe coating used for external corrosion control?	97
§195.563 Which pipelines must have cathodic protection?	97
§195.565 How do I install cathodic protection on breakout tanks?.....	97
§195.567 Which pipelines must have test leads and what must I do to install and maintain the leads?	98
§195.569 Do I have to examine exposed portions of buried pipelines?	98
§195.571 What criteria must I use to determine the adequacy of cathodic protection?	98
§195.573 What must I do to monitor external corrosion control?	98
§195.575 Which facilities must I electrically isolate and what inspections, tests, and safeguards are required?.....	100
§195.577 What must I do to alleviate interference currents?	100
§195.579 What must I do to mitigate internal corrosion?	100
§195.581 Which pipelines must I protect against atmospheric corrosion and what coating material may I use?	101
§195.583 What must I do to monitor atmospheric corrosion control?	101
§195.585 What must I do to correct corroded pipe?	101
§195.587 What methods are available to determine the strength of corroded pipe?	102
§195.588 What standards apply to direct assessment?	102
§195.589 What corrosion control information do I have to maintain?.....	105
§195.591 In-Line inspection of pipelines.	105
Appendix A to Part 195 - Delineation Between Federal and State Jurisdiction—Statement of Agency Policy and Interpretation	107
Appendix A to Part 195 - Delineation Between Federal and State Jurisdiction—Statement of Agency Policy and Interpretation	107
Example Appendix A - 1	110

Example Appendix A - 2 111
Example Appendix A - 3 112
Example Appendix A - 4a 113
Example Appendix A - 4b 114
Example Appendix A - 5a 115
Example Appendix A - 5b 116
Example Appendix A - 6 117
Example Appendix A - 7 118
Example Appendix A - 8 119
Example Appendix A - 9 120
Example Appendix A - 10 121
Appendix B to Part 195 - Risk-Based Alternative to Pressure Testing Older Hazardous Liquid and Carbon Dioxide Pipelines 122
Appendix C to Part 195 - Guidance for Implementation of an Integrity Management Program 125
Jurisdictional Tank Drawings 133
 Jurisdictional Tank Drawings 133
 Jurisdictional Tank Drawing 1 133
 Jurisdictional Tank Drawing 2 134
 Jurisdictional Tank Drawing 3 134
 Jurisdictional Tank Drawing 4 135
 Jurisdictional Tank Drawing 5 136
 Jurisdictional Tank Drawing 6 137
 Jurisdictional Tank Drawing 7 138

SubPart A - General (§§0-15)

SubPart A - General

- §195.0 [Scope.](#)
- §195.1 [Which pipelines are covered by this part?](#)
- §195.2 [Definitions.](#)
- §195.3 [Matter incorporated by reference in whole or in part](#)
- §195.4 [Compatibility necessary for transportation of hazardous liquids or carbon dioxide.](#)
- §195.5 [Conversion to service subject to this part.](#)
- §195.6 [Unusually Sensitive Areas \(USAs\)](#)
- §195.8 [Transportation of hazardous liquid or carbon dioxide in pipelines constructed with other than steel pipe.](#)
- §195.9 [Outer continental shelf pipelines](#)
- §195.10 [Responsibility of operator for compliance with this part.](#)
- §195.11 [What is a regulated rural gathering line and what requirements apply?](#)
- §195.12 [What requirements apply to low-stress pipelines in rural areas?](#)
- §195.13 [What requirements apply to pipelines transporting hazardous liquids by gravity?](#)
- §195.15 [What requirements apply to reporting-regulated-only gathering lines?](#)
- §195.18 [How to notify PHMSA.](#)

§195.0 Scope.

This part prescribes safety standards and reporting requirements for pipeline facilities used in the transportation of hazardous liquids or carbon dioxide.

[Amdt. 195-45, 56 FR 26925, June 12, 1991]

§195.1 Which pipelines are covered by this Part?

This section has been amended by Amdt. 195-107, eff. 6/28/24.

- (a) Covered. Except for the pipelines listed in paragraph (b) of this Section, this Part applies to pipeline facilities and the transportation of hazardous liquids or carbon dioxide associated with those facilities in or affecting interstate or foreign commerce, including pipeline facilities on the Outer Continental Shelf (OCS). Covered pipelines include, but are not limited to:
- (1) Any pipeline that transports a highly volatile liquid;
 - (2) Any pipeline segment that crosses a waterway currently used for commercial navigation;
 - (3) Except for a gathering line not covered by paragraph (a)(4) of this Section, any pipeline located in a rural or non-rural area of any diameter regardless of operating pressure;
 - (4) Any of the following onshore gathering lines used for transportation of petroleum:
 - (i) A pipeline located in a non-rural area;
 - (ii) A regulated rural gathering line as provided in § [195.11](#); or
 - (iii) A pipeline located in an inlet of the Gulf of Mexico as provided in § [195.413](#).

- (5) For purposes of the reporting requirements in subpart B of this part, any gathering line not already covered under paragraphs (a)(1), (2), (3) or (4) of this section.
- (b) Excepted. This Part does not apply to any of the following:
- (1) Transportation of a hazardous liquid transported in a gaseous state;
 - (2) Except for the reporting requirements of subpart B of this part, see § [195.13](#), transportation of a hazardous liquid through a pipeline by gravity.
 - (3) Transportation of a hazardous liquid through any of the following low-stress pipelines:
 - (i) A pipeline subject to safety regulations of the U.S. Coast Guard; or
 - (ii) A pipeline that serves refining, manufacturing, or truck, rail, or vessel terminal facilities, if the pipeline is less than one mile long (measured outside facility grounds) and does not cross an offshore area or a waterway currently used for commercial navigation;
 - (4) Except for the reporting requirements of subpart B of this part, see § [195.15](#), transportation of petroleum through an onshore rural gathering line that does not meet the definition of a "regulated rural gathering line" as provided in § 195.11. This exception does not apply to gathering lines in the inlets of the Gulf of Mexico subject to § [195.413](#).
 - (5) Transportation of hazardous liquid or carbon dioxide in an offshore pipeline in state waters where the pipeline is located upstream from the outlet flange of the following farthest downstream facility: The facility where hydrocarbons or carbon dioxide are produced or the facility where produced hydrocarbons or carbon dioxide are first separated, dehydrated, or otherwise processed;
 - (6) Transportation of hazardous liquid or carbon dioxide in a pipeline on the OCS where the pipeline is located upstream of the point at which operating responsibility transfers from a producing operator to a transporting operator;
 - (7) A pipeline segment upstream (generally seaward) of the last valve on the last production facility on the OCS where a pipeline on the OCS is producer-operated and crosses into state waters without first connecting to a transporting operator's facility on the OCS. Safety equipment protecting PHMSA-regulated pipeline segments is not excluded. A producing operator of a segment falling within this exception may petition the Administrator, under § 190.9 of this chapter, for approval to operate under PHMSA regulations governing pipeline design, construction, operation, and maintenance;
 - (8) Transportation of hazardous liquid or carbon dioxide through onshore production (including flow lines), refining, or manufacturing facilities or storage or in-plant piping systems associated with such facilities;
 - (9) Transportation of hazardous liquid or carbon dioxide:
 - (i) By vessel, aircraft, tank truck, tank car, or other non- pipeline mode of transportation; or
 - (ii) Through facilities located on the grounds of a materials transportation terminal if the facilities are used exclusively to transfer hazardous liquid or carbon dioxide between non-pipeline modes of transportation or between a non-pipeline mode and a pipeline. These facilities do not include any device and associated piping that are necessary to control pressure in the pipeline under § [195.406\(b\)](#); or
 - (10) Transportation of carbon dioxide downstream from the applicable following point:
 - (i) The inlet of a compressor used in the injection of carbon dioxide for oil recovery operations, or the point where recycled carbon dioxide enters the injection system, whichever is farther upstream; or

- (ii) The connection of the first branch pipeline in the production field where the pipeline transports carbon dioxide to an injection well or to a header or manifold from which a pipeline branches to an injection well.
- (c) *Breakout tanks.* Breakout tanks that are subject to this part must comply with requirements that apply specifically to breakout tanks and, to the extent applicable, with requirements that apply to pipeline systems and pipeline facilities. If a conflict exists between a requirement that applies specifically to breakout tanks and a requirement that applies to pipeline systems or pipeline facilities, the requirement that applies specifically to breakout tanks prevails. Anhydrous ammonia breakout tanks need not comply with §§ 195.132(b); 195.205(b); 195.264(b) and (e); 195.307; 195.428(c) through (d); and 195.432(b) and (c).

[Part 195 - Org., Oct. 4, 1969 as amended by Amdt. 195-1, 35 FR 5332, Mar. 31, 1970; Amdt. 195-22, 46 FR 38357, July 27, 1981; Amdt. 195-33, 50 FR 15895, Apr. 23, 1985; Amdt. 195-34, 50 FR 34470, Aug. 26, 1985; Amdt. 195-36, 52 FR 15005, April 22, 1986; Amdt. 195-36c, 51 FR 20976, June 10, 1986; Amdt. 195-45, 56 FR 26922, June 12, 1991; Amdt. 195-47, 56 FR 63764, Dec. 5, 1991; Amdt. 195-52, 59 FR 33388, June 28, 1994; Amdt. 195-53, 59 FR 35465, July 12, 1994, July 12, 1994; Amdt. 195-57, 62 FR 31364, June 9, 1997; Amdt. 195-57A, 62 FR 52511, Oct. 8, 1997; Amdt. 195-59, 62 FR 61692, Nov. 19, 1997; Amdt. 195-64, 63 FR 46692, Sept. 2, 1998; Amdt. 195-66, 64 FR 15926, April 2, 1999; Amdt. 195-72x, 68 FR 46109, July 29, 2003; No Number, 70 FR 11135, Mar. 8, 2005; Amdt. 195-89, 73 FR 31634, June 3, 2008; Amdt. 195-96, 76 FR 25576, May 5, 2011; Amdt. 195-102, 84 FR 52260, Oct. 1, 2019; Amdt. 195-107, 89 FR 33264, Apr. 29, 2024]

§195.2 Definitions.

As used in this part -

Abandoned means permanently removed from service.

Administrator means the Administrator, Pipeline and Hazardous Materials Safety Administration or his or her delegate.

Alarm means an audible or visible means of indicating to the controller that equipment or processes are outside operator-defined, safety-related parameters.

Barrel means a unit of measurement equal to 42 U.S. standard gallons.

Breakout tank means a tank used to (a) relieve surges in a hazardous liquid pipeline system or (b) receive and store hazardous liquid transported by a pipeline for reinjection and continued transportation by pipeline.

Carbon dioxide means a fluid consisting of more than 90 percent carbon dioxide molecules compressed to a supercritical state.

Component means any part of a pipeline which may be subjected to pump pressure including, but not limited to, pipe, valves, elbows, tees, flanges, and closures.

Computation Pipeline Monitoring (CPM) means a software-based monitoring tool that alerts the pipeline dispatcher of a possible pipeline operating anomaly that may be indicative of a commodity release.

Confirmed Discovery means when it can be reasonably determined, based on information available to the operator at the time a reportable event has occurred, even if only based on a preliminary evaluation.

Control room means an operations center staffed by personnel charged with the responsibility for remotely monitoring and controlling a pipeline facility.

Controller means a qualified individual who remotely monitors and controls the safety-related operations of a pipeline facility via a SCADA system from a control room, and who has operational authority and accountability for the remote operational functions of the pipeline facility.

Corrosive product means "corrosive material" as defined by §173.136 Class 8-Definitions of this chapter. *Entirely replaced onshore hazardous liquid or carbon dioxide pipeline segments*, for the purposes of §§ [195.258](#), [195.260](#), and [195.418](#), means where 2 or more miles of pipe, in the aggregate, have been replaced within any 5 contiguous miles within any 24-month period. This definition does not apply to any gathering line.

Exposed underwater pipeline means an underwater pipeline where the top of the pipe protrudes above the underwater natural bottom (as determined by recognized and generally accepted practices) in waters less than 15 feet (4.6 meters) deep, as measured from mean low water.

Flammable product means "flammable liquid" as defined by §173.120 Class 3-Definitions of this chapter.

Gathering line means a pipeline 219.1 mm (8 5/8 in) or less nominal outside diameter that transports petroleum from a production facility.

Gulf of Mexico and its inlets means the waters from the mean high water mark of the coast of the Gulf of Mexico and its inlets open to the sea (excluding rivers, tidal marshes, lakes, and canals) seaward to include the territorial sea and Outer Continental Shelf to a depth of 15 feet (4.6 meters), as measured from the mean low water.

Hazard to navigation means, for the purposes of this part, a pipeline where the top of the pipe is less than 12 inches (305 millimeters) below the underwater natural bottom (as determined by recognized and generally accepted practices) in waters less than 15 feet (4.6 meters) deep, as measured from the mean low water.

Hazardous liquid means petroleum, petroleum products, anhydrous ammonia, and ethanol or other non-petroleum fuel, including biofuel, which is flammable, toxic, or would be harmful to the environment if released in significant quantities.

Highly volatile liquid or HVL means a hazardous liquid which will form a vapor cloud when released to the atmosphere and which has a vapor pressure exceeding 276 kPa (40 psia) at 37.8 °C (100 °F).

In-Line Inspection (ILI) means the inspection of a pipeline from the interior of the pipe using an in-line inspection tool. Also called intelligent or smart pigging.

In-Line Inspection Tool or *Instrumented Internal Inspection Device* means a device or vehicle that uses a non-destructive testing technique to inspect the pipeline from the inside. Also known as intelligent or smart pig.

In-plant piping system means piping that is located on the grounds of a plant and used to transfer hazardous liquid or carbon dioxide between plant facilities or between plant facilities and a pipeline or other mode of transportation, not including any device and associated piping that are necessary to control pressure in the pipeline under [§195.406\(b\)](#).

Interstate pipeline means a pipeline or that part of a pipeline that is used in the transportation of hazardous liquids or carbon dioxide in interstate or foreign commerce.

Intrastate pipeline means a pipeline or that part of a pipeline to which this part applies that is not an interstate pipeline.

Line section means a continuous run of pipe between adjacent pressure pump stations, between a pressure pump station and terminal or breakout tanks, between a pressure pump station and a block valve, or between adjacent block valves.

Low-stress pipeline means a hazardous liquid pipeline that is operated in its entirety at a stress level of 20 percent or less of the specified minimum yield strength of the line pipe.

Maximum operating pressure (MOP) means the maximum pressure at which a pipeline or segment of a pipeline may be normally operated under this part.

Nominal wall thickness means the wall thickness listed in the pipe specifications.

Notification of potential rupture means the notification to, or observation by, an operator of indicia identified in [§ 195.417](#) of a potential unintentional or uncontrolled release of a large volume of commodity from a pipeline. This definition does not apply to any gathering line.

Offshore means beyond the line of ordinary low water along that portion of the coast of the United States that is in direct contact with the open seas and beyond the line marking the seaward limit of inland waters.

Operator means a person who owns or operates pipeline facilities.

Outer Continental Shelf means all submerged lands lying seaward and outside the area of lands beneath navigable waters as defined in Section 2 of the Submerged Lands Act (43 U.S.C. 1301) and of which the subsoil and seabed appertain to the United States and are subject to its jurisdiction and control.

Person means any individual, firm, joint venture, partnership, corporation, association, State, municipality, cooperative association, or joint stock association, and includes any trustee, receiver, assignee, or personal representative thereof.

Petroleum means crude oil, condensate, natural gasoline, natural gas liquids, and liquefied petroleum gas.

Petroleum product means flammable, toxic, or corrosive products obtained from distilling and processing of crude oil, unfinished oils, natural gas liquids, blend stocks and other miscellaneous hydrocarbon compounds.

Pipe or line pipe means a tube, usually cylindrical, through which a hazardous liquid or carbon dioxide flows from one point to another.

Pipeline or pipeline system means all parts of a pipeline facility through which a hazardous liquid or carbon dioxide moves in transportation, including, but not limited to, line pipe, valves, and other appurtenances connected to line pipe, pumping units, fabricated assemblies associated with pumping units, metering and delivery stations and fabricated assemblies therein, and breakout tanks.

Pipeline facility means new and existing pipe, rights-of-way and any equipment, facility, or building used in the transportation of hazardous liquids or carbon dioxide.

Production facility means piping or equipment used in the production, extraction, recovery, lifting, stabilization, separation or treating of petroleum or carbon dioxide, or associated storage or measurement. (To be a production facility under this definition, piping or equipment must be used in the process of extracting petroleum or carbon dioxide from the ground or from facilities where CO₂ is produced, and preparing it for transportation by pipeline. This includes piping between treatment plants which extract carbon dioxide, and facilities utilized for the injection of carbon dioxide for recovery operations.)

Rupture-mitigation valve (RMV) means an automatic shut-off valve (ASV) or a remote-control valve (RCV) that a pipeline operator uses to minimize the volume of hazardous liquid or carbon dioxide released from the pipeline and to mitigate the consequences of a rupture. This definition does not apply to any gathering line.

Rural area means outside the limits of any incorporated or unincorporated city, town, village, or any other designated residential or commercial area such as a subdivision, a business or shopping center, or community development.

Significant Stress Corrosion Cracking means a stress corrosion cracking (SCC) cluster in which the deepest crack, in a series of interacting cracks, is greater than 10% of the wall thickness and the total interacting length of the cracks is equal to or greater than 75% of the critical length of a 50% through-wall flaw that would fail at a stress level of 110% of SMYS.

Specified minimum yield strength means the minimum yield strength, expressed in p.s.i. (kPa) gage, prescribed by the specification under which the material is purchased from the manufacturer.

Stress level means the level of tangential or hoop stress, usually expressed as a percentage of specified minimum yield strength.

Supervisory Control and Data Acquisition (SCADA) system means a computer-based system or systems used by a controller in a control room that collects and displays information about a pipeline facility and may have the ability to send commands back to the pipeline facility.

Surge pressure means pressure produced by a change in velocity of the moving stream that results from shutting down a pump station or pumping unit, closure of a valve, or any other blockage of the moving stream.

Toxic product means "poisonous material" as defined by §173.132 Class 6, Division 6.1-Definitions of this chapter.

Unusually Sensitive Area (USA) means a drinking water or ecological resource area that is unusually sensitive to environmental damage from a hazardous liquid pipeline release, as identified under [§195.6](#).

Welder means a person who performs manual or semi-automatic welding.

Welding operator means a person who operates machine or automatic welding equipment.

[Amdt. 195-22, 46 FR 38360, July 27, 1981; 47 FR 32721, July 29, 1982; Amdt 195-105, 87 FR 20940, Apr. 8, 2022; Amdt. 195-106, 88 FR 50056, Aug. 1, 2023]

§195.3 What documents are incorporated by reference partly or wholly in this part?

This section has been amended by Amdt. 195-107, eff. 6/28/24.

- (a) Certain material is incorporated by reference into this part with the approval of the Director of the Federal Register under 5 U.S.C. 552(a) and 1 CFR part 51. All approved incorporation by reference (IBR) material is available for inspection at the Pipeline and Hazardous Materials Safety Administration (PHMSA) and at the National Archives and Records Administration (NARA). Contact PHMSA at: Office of Pipeline Safety, Pipeline and Hazardous Materials Safety Administration, 1200 New Jersey Avenue SE, Washington, DC 20590; (202) 366-4046; www.phmsa.dot.gov/pipeline/regs. For information on inspecting this material at NARA, visit www.archives.gov/federal-register/cfr/ibr-locations.html or email fr.inspection@nara.gov. It is also available from the sources in the following paragraphs of this section.
- (b) American Petroleum Institute (API), 200 Massachusetts Avenue NW, Suite 1100, Washington, DC 20001-5571; phone: (202) 682-8000; website: www.api.org/.
- (1) API Recommended Practice 5L1, "Recommended Practice for Railroad Transportation of Line Pipe," 7th edition, September 2009, (API RP 5L1), IBR approved for [§195.207\(a\)](#).
 - (2) API Recommended Practice 5LT, "Recommended Practice for Truck Transportation of Line Pipe," First edition, March 12, 2012, (API RP 5LT), IBR approved for [§195.207\(c\)](#).
 - (3) API Recommended Practice 5LW, "Recommended Practice Transportation of Line Pipe on Barges and Marine Vessels," 3rd edition, September 2009, (API RP 5LW), IBR approved for [§ 195.207\(b\)](#).
 - (4) API Recommended Practice 651, Cathodic Protection of Aboveground Petroleum Storage Tanks, 4th edition, September 2014, (API RP 651); IBR approved for [§§ 195.565 and 195.573\(d\)](#).
 - (5) ANSI/API Recommended Practice 652, "Linings of Aboveground Petroleum Storage Tank Bottoms," 3rd edition, October 2005, (API RP 652), IBR approved for [§195.579\(d\)](#).
 - (6) API Recommended Practice 1130, "Computational Pipeline Monitoring for Liquids: Pipeline Segment," 3rd edition, September 2007, (API RP 1130), IBR approved for [§§195.134 and 195.444](#).
 - (7) API Recommended Practice 1162, "Public Awareness Programs for Pipeline Operators," 1st edition, December 2003, (API RP 1162), IBR approved for [§195.440\(a\), \(b\), and \(c\)](#).
 - (8) API Recommended Practice 1165, "Recommended Practice for Pipeline SCADA Displays," First edition, January 2007, (API RP 1165), IBR approved for [§195.446\(c\)](#).
 - (9) API Recommended Practice 1168, "Pipeline Control Room Management," First edition, September 2008, (API RP 1168), IBR approved for [§195.446\(c\) and \(f\)](#).

- (10) API Recommended Practice 2003, “Protection against Ignitions Arising out of Static, Lightning, and Stray Currents,” 7th edition, January 2008, (API RP 2003), IBR approved for §[195.405\(a\)](#).
- (11) API Recommended Practice 2026, “Safe Access/Egress Involving Floating Roofs of Storage Tanks in Petroleum Service,” 3rd edition, June 2017, (API RP 2026); IBR approved for §[195.405\(b\)](#).
- (12) API Specification 5L, Line Pipe, 46th edition, April 2018, including Errata 1 (May 2018), (API Spec 5L) IBR approved for § [195.106\(b\)](#) and (e).
- (13) API Specification Spec 6D, Specification for Pipeline and Piping Valves, 24th edition, August 2014, including Errata 1 through 10 (October 2014 through July 2021), Addendum 1 (March 2015), and Addendum 2 (June 2016), (API Spec 6D); IBR approved for § [195.116\(d\)](#).
- (14) API Specification 12F, “Specification for Shop Welded Tanks for Storage of Production Liquids,” 12th edition, October 2008, effective April 1, 2009, (API Spec 12F), IBR approved for §§[195.132\(b\)](#); [195.205\(b\)](#); [195.264\(b\)](#) and (e); [195.307\(a\)](#); [195.565](#); [195.579\(d\)](#).
- (15) API Standard 510, “Pressure Vessel Inspection Code: In-Service Inspection, Rating, Repair, and Alteration,” 9th edition, June 2006, (API Std 510), IBR approved for §§[195.205\(b\)](#); [195.432\(c\)](#).
- (16) API Standard 620, Design and Construction of Large, Welded, Low-Pressure Storage Tanks, 12th edition, effective October 2013, including Addendum 1 (November 2014) (API Std 620); IBR approved for §§ [195.132\(b\)](#); [195.205\(b\)](#); [195.264\(b\)](#), and (e); [195.307\(b\)](#); [195.565](#); [195.579\(d\)](#).
- (17) API Standard 650, Welded Tanks for Oil Storage, 13th edition, March 2020, including Errata 1 (January 2021), (API Std 650); IBR approved for §§ [195.132\(b\)](#); [195.205\(b\)](#); [195.264\(b\)](#), (e); [195.307\(c\)](#), (d); [195.565](#); [195.579\(d\)](#).
- (18) API Standard 653, “Tank Inspection, Repair, Alteration, and Reconstruction,” 3rd edition, December 2001, (including addendum 1 (September 2003), addendum 2 (November 2005), addendum 3 (February 2008), and errata (April 2008)), (API Std 653), IBR approved for §§[195.205\(b\)](#), [195.307\(d\)](#), and [195.432\(b\)](#).
- (19) API Standard 1104, Welding of Pipelines and Related Facilities, 21st edition, September 2013, including Errata 1 through 5 (April 2014 through September 2018), Addendum 1 (July 2014), and Addendum 2 (May 2016); IBR approved for §§ [195.214\(a\)](#); [195.222\(a\)](#) and (b); [195.228\(b\)](#).
- (20) API Standard 1163, “In-Line Inspection Systems Qualification” Second edition, April 2013, (API Std 1163), IBR approved for § [195.591](#).
- (21) API Standard 2000, Venting Atmospheric and Low-pressure Storage Tanks, 7th Edition, March 2014, Reaffirmed April 2020, (API Std 2000), IBR approved for § [195.264\(e\)](#).
- (22) API Standard 2350, “Overfill Prevention for Storage Tanks in Petroleum Facilities,” 5th edition, September 2020, (API Std 2350), including Errata 1 (April 2021); IBR approved for § [195.428\(c\)](#).
- (23) API Standard 2510, “Design and Construction of LPG Installations,” 8th edition, 2001, (API Std 2510), IBR approved for §§[195.132\(b\)](#), [195.205\(b\)](#), [195.264 \(b\)](#), (e); [195.307 \(e\)](#), [195.428 \(c\)](#); and [195.432 \(c\)](#).
- (c) The American Society of Mechanical Engineers (ASME), Two Park Avenue, New York, NY 10016; phone: (800) 843-2763; website: <http://www.asme.org/>.
- (1) ASME/ANSI B16.9-2007, “Factory-Made Wrought Butt welding Fittings,” December 7, 2007, (ASME/ANSI B16.9), IBR approved for §[195.118\(a\)](#).
- (2) ASME/ANSI B31G-1991 (Reaffirmed 2004), “Manual for Determining the Remaining Strength of Corroded Pipelines,” 2004, (ASME/ANSI B31G), IBR approved for §§[195.452\(h\)](#); [195.587](#); and [195.588\(c\)](#).
- (3) ASME B31.4-2006, Pipeline Transportation Systems for Liquid Hydrocarbons and Other Liquids, October 20, 2006, (ASME B31.4); IBR approved for § [195.110\(a\)](#).
- (4) ASME B31.8-2018, Gas Transmission and Distribution Piping Systems, Issued November 20, 2018, (ASME B31.8); IBR approved for §§ [195.5\(a\)](#); [195.406\(a\)](#).

- (5) ASME Boiler & Pressure Vessel Code, Section VIII, Division 1, “Rules for Construction of Pressure Vessels,” 2007 edition, July 1, 2007, (ASME BPVC, Section VIII, Division 1), IBR approved for §§[195.124](#) and [195.307](#)(e).
 - (6) ASME Boiler & Pressure Vessel Code, Section VIII, Division 2, “Alternate Rules, Rules for Construction of Pressure Vessels,” 2007 edition, July 1, 2007, (ASME BPVC, Section VIII, Division 2), IBR approved for §[195.307](#)(e).
 - (7) ASME Boiler & Pressure Vessel Code, Section IX: “Qualification Standard for Welding and Brazing Procedures, Welders, Brazers, and Welding and Brazing Operators,” 2007 edition, July 1, 2007, (ASME BPVC, Section IX), IBR approved for §[195.222](#)(a).
- d) American Society for Nondestructive Testing, P.O. Box 28518, 1711 Arlingate Lane, Columbus, OH 43228. <https://asnt.org>.
- (1) ANSI/ASNT ILI-PQ-2005(2010), “In-line Inspection Personnel Qualification and Certification” reapproved October 11, 2010, (ANSI/ ASNT ILI-PQ), IBR approved for § [195.591](#).
 - (2) [Reserved]
- (e) ASTM International (ASTM), 100 Barr Harbor Drive, P.O. Box C700, West Conshohocken, PA 119428; phone: (610) 832-9585; email: service@astm.org; website: <http://www.astm.org/>.
- (1) ASTM A53/A53M-20, Standard Specification for Pipe, Steel, Black and Hot-Dipped, Zinc-Coated, Welded and Seamless, approved July 1, 2020, (ASTM A53/A53M); IBR approved for § [195.106](#)(e).
 - (2) ASTM A106/A106M-19A, Standard Specification for Seamless Carbon Steel Pipe for High-Temperature Service, approved November 1, 2019, (ASTM A106/A106M); IBR approved for § [195.106](#)(e).
 - (3) ASTM A333/A333M-18, Standard Specification for Seamless and Welded Steel Pipe for Low-Temperature Service and Other Applications with Required Notch Toughness, approved November 1, 2018, (ASTM A333/A333M); IBR approved for § [195.106](#)(e).
 - (4) ASTM A381/A381M-18, Standard Specification for Metal-Arc-Welded Carbon or High-Strength Low-Alloy Steel Pipe for Use with High-Pressure Transmission Systems, approved November 1, 2018, (ASTM A381); IBR approved for § [195.106](#)(e).
 - (5) ASTM A671/A671M-20, Standard Specification for Electric-Fusion-Welded Steel Pipe for Atmospheric and Lower Temperatures, approved March 1, 2020, (ASTM A671/A671M); IBR approved for § [195.106](#)(e).
 - (6) ASTM A672/A672M-09, Standard Specification for Electric-Fusion-Welded Steel Pipe for High-Pressure Service at Moderate Temperatures, approved October 1, 2009, (ASTM A672/A672M); IBR approved for § [195.106](#)(e).
 - (7) ASTM A691/A691M-19, Standard Specification for Carbon and Alloy Steel Pipe, Electric-Fusion-Welded for High-Pressure Service at High Temperatures, approved November 1, 2019, (ASTM A691/A691M); IBR approved for § [195.106](#)(e).
- (f) Manufacturers Standardization Society of the Valve and Fittings Industry, Inc. (MSS), 127 Park St. NE, Vienna, VA 22180; phone: (703) 281-6613; website: www.mss-hq.org/.
- (1) MSS SP-75-2019 Standard Practice, High-Strength, Wrought, Butt-Welding Fittings, published December 2019, (MSS SP-75); IBR approved for § [195.118](#)(a).
 - (2) [Reserved]
- (g) Association for Materials Protection and Performance (AMPP), 15835 Park Ten Place, Houston, TX 77084; phone: (800) 797-6223; website: <https://ampp.org/standards>.

- (1) NACE SP0169-2007, Standard Practice, "Control of External Corrosion on Underground or Submerged Metallic Piping Systems" reaffirmed March 15, 2007, (NACE SP0169), IBR approved for §§[195.571](#) and [195.573\(a\)](#).
 - (2) ANSI/NACE SP0502-2010, Standard Practice, "Pipeline External Corrosion Direct Assessment Methodology," June 24, 2010, (NACE SP0502), IBR approved for §[195.588\(b\)](#).
 - (3) NACE SP0102-2010, "Standard Practice, Inline Inspection of Pipelines" revised March 13, 2010, (NACE SP0102), IBR approved for §§[195.120](#) and [195.591](#).
 - (4) NACE SP0204-2015, Stress Corrosion Cracking (SSC) Direct Assessment Methodology, Revised March 14, 2015, (NACE SP0204); IBR approved for § [195.588\(c\)](#).
- (h) National Fire Protection Association (NFPA), 1 Batterymarch Park, Quincy, MA 02169, phone: 617-984-7275, Web site: <http://www.nfpa.org/>.
- (1) NFPA-30 (2012), "Flammable and Combustible Liquids Code," including Errata 30-12-1 (9/27/11), and Errata 30-12-2 (11/14/11), 2012 edition, copyright 2011, (NFPA-30), IBR approved for §[195.264\(b\)](#).
 - (2) [Reserved]
- (i) Pipeline Research Council International, Inc. (PRCI), c/o Technical Toolboxes, 3801 Kirby Drive, Suite 520, P.O. Box 980550, Houston, TX 77098, phone: 713-630-0505, toll free: 866-866-6766, Web site: <http://www.ttoolboxes.com/>.
- (1) AGA Pipeline Research Committee, Project PR-3-805 "A Modified Criterion for Evaluating the Remaining Strength of Corroded Pipe," December 22, 1989, (PR-3-805 (RSTRING)). IBR approved for §§ 195.452(h); [195.587](#); and [195.588\(c\)](#).
 - (2) [Reserved]

[34 FR 15473, Oct. 4, 1969 as amended by Amdt. 195-5, 38 FR 2977, Jan. 31, 1973; Amdt. 195-9, 41 FR 13590, Mar. 31, 1976; Amdt. 195-14, 43 FR 18553, May 1, 1978; Amdt. 195-21, 46 FR 10157, Feb. 2, 1981; 195-22, 46 FR 38357, July 27, 1981; Amdt. 195-32, 49 FR 36859, Sept. 20, 1984; Amdt. 195-37, 51 FR 15333, April 23, 1986; Amdt. 195-40, 54 FR 5625, 54 FR 5625, Feb. 6, 1989; Amdt. 195-41, 54 FR 22781, July 3, 1989; Amdt. 195-43, 54 FR 32344, Aug. 7, 1989; Amdt. 195-45, 56 FR 26922, June 12, 1991; Amdt. 195-48, 58 FR 14519, Mar. 18, 1993; Amdt. 195-52, 59 FR 33388, June 28, 1994, Amdt. 195-56, 61 FR 26121, June 24, 1996, Amdt. 195-56c, 61 FR 36825, Aug 14, 1996; Amdt. 195-61, 63 FR 7721, Feb. 17, 1998; Amdt. 195-62 63 FR 36373, July 6, 1998; Amdt. 195-66, 64 FR 15926, April 2, 1999; Amdt. 195-66A, 65 FR 4770, Jan 31, 2000; Amdt. 195-73, 66 FR 66993, December 27, 2001; Amdt. 195-81, 69 FR 32886, Apr 23, 2004; No Number, 70 FR 11135, March 8, 2005; Amdt. 195-83, 70 FR 28833, May 19, 2005; Amdt. 195-85, 70 CFR 61571, October 25, 2005; Amdt. 195-86, 71 FR 33402, June 9, 2006; Amdt. 195-88, 73 FR 16562, March 28, 2008, Amdt. 195-90, 74 FR 2889, January 16, 2009; Amdt. 195-91, 74 FR 17099, April 14, 2009; Amdt. 195-93, 74 FR 63310, December 3, 2009; Amdt. 195-94, 75 FR 48593, August 11, 2010; Amdt. 195-99, 80 FR 168, Jan. 5, 2015; Amdt. 195-101, 82 FR 7972, Jan. 23, 2017; Amdt. 195-102, 84 FR 52260, Oct. 1, 2019; Amdt. 195-107, 89 FR 33264, Apr. 29, 2024]

§195.4 Compatibility necessary for transportation of hazardous liquids or carbon dioxide.

No person may transport any hazardous liquid or carbon dioxide unless the hazardous liquid or carbon dioxide is chemically compatible with both the pipeline, including all components, and any other commodity that it may come into contact with while in the pipeline.

[Amdt. 195-45, 56 FR 26925, June 12, 1991]

§195.5 Conversion to service subject to this part.

This section has been amended by Amdt. 195-107, eff. 6/28/24.

- (a) A steel pipeline previously used in service not subject to this part qualifies for use under this part if the operator prepares and follows a written procedure to accomplish the following:
- (1) The design, construction, operation, and maintenance history of the pipeline must be reviewed and, where sufficient historical records are not available, appropriate tests must be performed to determine if the pipeline is in satisfactory condition for safe operation. If one or more of the variables necessary to verify the design pressure under [§195.106](#) or to perform the testing under paragraph (a) (4) of this section is unknown, the design pressure may be verified and the maximum operating pressure determined by-
 - (i) Testing the pipeline in accordance with ASME B31.8 (incorporated by reference, see [§195.3](#)), Appendix N, to produce a stress equal to the yield strength; and
 - (ii) Applying, to not more than 80 percent of the first pressure that produces a yielding, the design factor F in [§195.106\(a\)](#) and the appropriate factors in [§195.106\(e\)](#).
 - (2) The pipeline right-of-way, all aboveground segments of the pipeline, and appropriately selected underground segments must be visually inspected for physical defects and operating conditions which reasonably could be expected to impair the strength or tightness of the pipeline.
 - (3) All known unsafe defects and conditions must be corrected in accordance with this part.
 - (4) The pipeline must be tested in accordance with [subpart E](#) of this part to substantiate the maximum operating pressure permitted by [§195.406](#).
- (b) A pipeline that qualifies for use under this section need not comply with the corrosion control requirements of [subpart H](#) of this part until 12 months after it is placed into service, notwithstanding any previous deadlines for compliance.
- (c) Each operator must keep for the life of the pipeline a record of the investigations, tests, repairs, replacements, and alterations made under the requirements of paragraph (a) of this section.
- (d) An operator converting a pipeline from service not previously covered by this part must notify PHMSA 60 days before the conversion occurs as required by [§ 195.64](#).

[Amdt. 195-22, 46 FR 38360, July 27, 1981, as amended by Amdt. 195-52, 59 FR 33396, June 28, 1994; Amdt. 195-173, 66 FR 67004, Dec. 27, 2001; Amdt. 195-99, 80 FR 184, Jan. 5, 2015; Amdt. 195-101, 82 FR 7999, Jan. 23, 2017; Amdt. 195-107, 89 FR 33264, Apr. 29, 2024]

§195.6 Unusually Sensitive Areas (USAs).

As used in this part, a USA means a drinking water or ecological resource area that is unusually sensitive to environmental damage from a hazardous liquid pipeline release.

- (a) An *USA drinking water resource* is:
- (1) The water intake for a Community Water System (CWS) or a Non-transient Non-community Water System (NTNCWS) that obtains its water supply primarily from a surface water source and does not have an adequate alternative drinking water source;
 - (2) The Source Water Protection Area (SWPA) for a CWS or a NTNCWS that obtains its water supply from a Class I or Class IIA aquifer and does not have an adequate alternative drinking water source. Where a state has not yet identified the SWPA, the Wellhead Protection Area (WHPA) will be used until the state has identified the SWPA; or

(3) The sole source aquifer recharge area where the sole source aquifer is a karst aquifer in nature.

(b) An *USA ecological resource* is:

- (1) An area containing a critically imperiled species or ecological community;
- (2) A multi-species assemblage area;
- (3) A migratory waterbird concentration area;
- (4) An area containing an imperiled species, threatened or endangered species, depleted marine mammal species, or an imperiled ecological community where the species or community is aquatic, aquatic dependent, or terrestrial with a limited range;
- (5) An area containing an imperiled species, threatened or endangered species, depleted marine mammal species, or imperiled ecological community where the species or community occurrence is considered to be one of the most viable, highest quality, or in the best condition, as identified by an element occurrence ranking (EORANK) of A (excellent quality) or B (good quality) or
- (6) A coastal beach; or
- (7) Certain coastal waters.

(c) Definitions used in this part-

Adequate Alternative Drinking Water Source means a source of water that currently exists, can be used almost immediately with a minimal amount of effort and cost, involves no decline in water quality, and will meet the consumptive, hygiene, and fire fighting requirements of the existing population of impacted customers for at least one month for a surface water source of water and at least six months for a groundwater source.

Aquatic or Aquatic Dependent Species or Community means a species or community that primarily occurs in aquatic, marine, or wetland habitats, as well as species that may use terrestrial habitats during all or some portion of their life cycle, but that are still closely associated with or dependent upon aquatic, marine, or wetland habitats for some critical component or portion of their life-history (i.e., reproduction, rearing and development, feeding, etc).

Class I Aquifer means an aquifer that is surficial or shallow, permeable, and is highly vulnerable to contamination. Class I aquifers include:

- (1) Unconsolidated Aquifers (Class Ia) that consist of surficial, unconsolidated, and permeable alluvial, terrace, outwash, beach, dune and other similar deposits. These aquifers generally contain layers of sand and gravel that, commonly, are interbedded to some degree with silt and clay. Not all Class Ia aquifers are important water-bearing units, but they are likely to be both permeable and vulnerable. The only natural protection of these aquifers is the thickness of the unsaturated zone and the presence of fine-grained material;
- (2) Soluble and Fractured Bedrock Aquifers (Class Ib). Lithologies in this class include limestone, dolomite, and, locally, evaporitic units that contain documented karst features or solution channels, regardless of size. Generally these aquifers have a wide range of permeability. Also included in this class are sedimentary strata, and metamorphic and igneous (intrusive and extrusive) rocks that are significantly faulted, fractured, or jointed. In all cases groundwater movement is largely controlled by secondary openings. Well yields range widely, but the important feature is the potential for rapid vertical and lateral ground water movement along preferred pathways, which result in a high degree of vulnerability;
- (3) Semiconsolidated Aquifers (Class Ic) that generally contain poorly to moderately indurated sand and gravel that is interbedded with clay and silt. This group is intermediate to the unconsolidated and consolidated end members. These systems are common in the Tertiary age rocks that are exposed throughout the Gulf and Atlantic coastal states. Semiconsolidated

conditions also arise from the presence of intercalated clay and caliche within primarily unconsolidated to poorly consolidated units, such as occurs in parts of the High Plains Aquifer; or

- (4) Covered Aquifers (Class Id) that are any Class I aquifer overlain by less than 50 feet of low permeability, unconsolidated material, such as glacial till, lacustrian, and loess deposits.

Certain coastal waters means the territorial sea of the United States; the Great Lakes and their connecting waters; and the marine and the estuarine waters of the United States up to the head of tidal influence.

Class Ila aquifer means a Higher Yield Bedrock Aquifer that is consolidated and is moderately vulnerable to contamination. These aquifers generally consist of fairly permeable sandstone or conglomerate that contain lesser amounts of interbedded fine grained clastics (shale, siltstone, mudstone) and occasionally carbonate units. In general, well yields must exceed 50 gallons per minute to be included in this class. Local fracturing may contribute to the dominant primary porosity and permeability of these systems.

Coastal beach means any land between the high- and low- water marks of certain coastal waters.

Community Water System (CWS) means a public water system that serves at least 15 service connections used by year-round residents of the area or regularly serves at least 25 year-round residents.

Critically imperiled species or ecological community (habitat) means an animal or plant species or an ecological community of extreme rarity, based on The Nature Conservancy's Global Conservation Status Rank. There are generally 5 or fewer occurrences, or very few remaining individuals (less than 1,000) or acres (less than 2,000). These species and ecological communities are extremely vulnerable to extinction due to some natural or man-made factor.

Depleted marine mammal species means a species that has been identified and is protected under the Marine Mammal Protection Act of 1972, as amended (MMPA) (16 U.S.C. 1361 et seq.). The term "depleted" refers to marine mammal species that are listed as threatened or endangered, or are below their optimum sustainable populations (16 U.S.C. 1362). The term "marine mammal" means "any mammal which is morphologically adapted to the marine environment (including sea otters and members of the orders Sirenia, Pinnipedia, and Cetacea), or primarily inhabits the marine environment (such as the polar bear)" (16 U.S.C. 1362). The order Sirenia includes manatees, the order Pinnipedia includes seals, sea lions, and walrus, and the order Cetacea includes dolphins, porpoises, and whales.

Ecological community means an interacting assemblage of plants and animals that recur under similar environmental conditions across the landscape.

Element occurrence rank (EORANK) means the condition or viability of a species or ecological community occurrence, based on a population's size, condition, and landscape context. EORANKs are assigned by the Natural Heritage Programs. An EORANK of A means an excellent quality and an EORANK of B means good quality.

Imperiled species or ecological community (habitat) means a rare species or ecological community, based on The Nature Conservancy's Global Conservation Status Rank. There are generally 6 to 20 occurrences, or few remaining individuals (1,000 to 3,000) or acres (2,000 to 10,000). These species and ecological communities are vulnerable to extinction due to some natural or man-made factor.

Karst aquifer means an aquifer that is composed of limestone or dolomite where the porosity is derived from connected solution cavities. Karst aquifers are often cavernous with high rates of flow.

Migratory waterbird concentration area means a designated Ramsar site or a Western Hemisphere Shorebird Reserve Network site.

Multi-species assemblage area means an area where three or more different critically imperiled or imperiled species or ecological communities, threatened or endangered species, depleted marine mammals, or migratory waterbird concentrations co-occur.

Non-transient Non-community Water System (NTNCWS) means a public water system that regularly serves at least 25 of the same persons over six months per year. Examples of these systems include schools, factories, and hospitals that have their own water supplies.

Public Water System (PWS) means a system that provides the public water for human consumption through pipes or other constructed conveyances, if such system has at least 15 service connections or regularly serves an average of at least 25 individuals daily at least 60 days out of the year. These systems include the sources of the water supplies - i.e., surface or ground. PWS can be community, non-transient non-community, or transient non-community systems.

Ramsar site means a site that has been designated under The Convention on Wetlands of International Importance Especially as Waterfowl Habitat program. Ramsar sites are globally critical wetland areas that support migratory waterfowl. These include wetland areas that regularly support 20,000 waterfowl; wetland areas that regularly support substantial numbers of individuals from particular groups of waterfowl, indicative of wetland values, productivity, or diversity; and wetland areas that regularly support 1% of the individuals in a population of one species or subspecies of waterfowl.

Sole source aquifer (SSA) means an area designated by the U.S. Environmental Protection Agency under the Sole Source Aquifer program as the "sole or principal" source of drinking water for an area. Such designations are made if the aquifer's ground water supplies 50% or more of the drinking water for an area, and if that aquifer were to become contaminated, it would pose a public health hazard. A sole source aquifer that is karst in nature is one composed of limestone where the porosity is derived from connected solution cavities. They are often cavernous, with high rates of flow.

Source Water Protection Area (SWPA) means the area delineated by the state for a public water supply system (PWS) or including numerous PWSs, whether the source is ground water or surface water or both, as part of the state source water assessment program (SWAP) approved by EPA under section 1453 of the Safe Drinking Water Act.

Species means species, subspecies, population stocks, or distinct vertebrate populations.

Terrestrial ecological community with a limited range means a non-aquatic or non-aquatic dependent ecological community that covers less than five (5) acres.

Terrestrial species with a limited range means a non-aquatic or non-aquatic dependent animal or plant species that has a range of no more than five (5) acres.

Threatened and endangered species (T&E) means an animal or plant species that has been listed and is protected under the Endangered Species Act of 1973, as amended (ESA73) (16 U.S.C. 1531 et seq.). "Endangered species" is defined as "any species which is in danger of extinction throughout all or a significant portion of its range" (16 U.S.C. 1532). "Threatened species" is defined as "any species which is likely to become an endangered species within the foreseeable future throughout all or a significant portion of its range" (16 U.S.C. 1532).

Transient Non-community Water System (TNCWS) means a public water system that does not regularly serve at least 25 of the same persons over six months per year. This type of water system serves a transient population found at rest stops, campgrounds, restaurants, and parks with their own source of water.

Wellhead Protection Area (WHPA) means the surface and subsurface area surrounding a well or well field that supplies a public water system through which contaminants are likely to pass and eventually reach the water well or well field.

Western Hemisphere Shorebird Reserve Network (WHSRN) site means an area that contains migratory shorebird concentrations and has been designated as a hemispheric reserve, international reserve, regional reserve, or endangered species reserve. Hemispheric reserves host at least 500,000 shorebirds annually or 30% of a species flyway population. International reserves host 100,000 shorebirds annually or 15% of a species flyway population. Regional reserves host 20,000 shorebirds annually or 5% of a species flyway population. Endangered species reserves are critical to the survival of endangered species and no minimum number of birds is required.

[Amdt. 195-71, 65 FR 80544, Dec. 21, 2000, as amended at 86 FR 73186, Dec. 27, 2021]

§195.8 Transportation of hazardous liquid or carbon dioxide in pipelines constructed with other than steel pipe.

No person may transport any hazardous liquid or carbon dioxide through a pipe that is constructed after October 1, 1970, for hazardous liquids or after July 12, 1991 for carbon dioxide of material other than steel unless the person has notified the Administrator in writing at least 90 days before the transportation is to begin. The notice must state whether carbon dioxide or a hazardous liquid is to be transported and the chemical name, common name, properties and characteristics of the hazardous liquid to be transported and the material used in construction of the pipeline. If the Administrator determines that the transportation of the hazardous liquid or carbon dioxide in the manner proposed would be unduly hazardous, he will, within 90 days after receipt of the notice, order the person that gave the notice, in writing, not to transport the hazardous liquid or carbon dioxide in the proposed manner until further notice.

[Amdt. 195-45, 56 FR 26925, June 12, 1991, as amended by Amdt. 195-50, 59 FR 17281, Apr. 12, 1994]

§195.9 Outer continental shelf pipelines.

Operators of transportation pipelines on the Outer Continental Shelf must identify on all their respective pipelines the specific points at which operating responsibility transfers to a producing operator. For those instances in which the transfer points are not identifiable by a durable marking, each operator will have until September 15, 1998 to identify the transfer points. If it is not practicable to durably mark a transfer point and the transfer point is located above water, the operator must depict the transfer point on a schematic maintained near the transfer point. If a transfer point is located subsea, the operator must identify the transfer point on a schematic which must be maintained at the nearest upstream facility and provided to PHMSA upon request. For those cases in which adjoining operators have not agreed on a transfer point by September 15, 1998 the Regional Director and the MMS Regional Supervisor will make a joint determination of the transfer point.

[Amdt. 195-59, 62 FR 61695, Nov. 19, 1997, as amended at 70 FR 11140, Mar. 8, 2005]

§195.11 What is a regulated rural gathering line and what requirements apply?

Each operator of a regulated rural gathering line, as defined in paragraph (a) of this section, must comply with the safety requirements described in paragraph (b) of this section.

- (a) *Definition.* As used in this section, a regulated rural gathering line means an onshore gathering line in a rural area that meets all of the following criteria-
- (1) Has a nominal diameter from 6 5/8 inches (168 mm) to 8 5/8 inches (219.1 mm);
 - (2) Is located in or within one-quarter mile (.40 km) of an unusually sensitive area as defined in [§ 195.6](#); and
 - (3) Operates at a maximum pressure established under [§ 195.406](#) corresponding to-
 - (i) A stress level greater than 20-percent of the specified minimum yield strength of the line pipe; or
 - (ii) If the stress level is unknown or the pipeline is not constructed with steel pipe, a pressure of more than 125 psi (861 kPa) gage.
- (b) *Safety requirements.* Each operator must prepare, follow, and maintain written procedures to carry out the requirements of this section. Except for the requirements in paragraphs (b)(2), (b)(3), (b)(9) and (b)(10) of this section, the safety requirements apply to all materials of construction.
- (1) Identify all segments of pipeline meeting the criteria in paragraph (a) of this section before April 3, 2009.
 - (2) For steel pipelines constructed, replaced, relocated, or otherwise changed after July 3, 2009:
 - (i) Design, install, construct, initially inspect, and initially test the pipeline in compliance with this part, unless the pipeline is converted under [§ 195.5](#).
 - (ii) [Reserved]
 - (3) For non-steel pipelines constructed after July 3, 2009, notify the Administrator according to [§ 195.8](#).
 - (4) Beginning no later than January 3, 2009, comply with the reporting requirements in [subpart B](#) of this part.
 - (5) Establish the maximum operating pressure of the pipeline according to [§ 195.406](#) before transportation begins, or if the pipeline exists on July 3, 2008, before July 3, 2009.
 - (6) Install line markers according to [§ 195.410](#) before transportation begins, or if the pipeline exists on July 3, 2008, before July 3, 2009. Continue to maintain line markers in compliance with [§ 195.410](#).
 - (7) Establish a continuing public education program in compliance with [§ 195.440](#) before transportation begins, or if the pipeline exists on July 3, 2008, before January 3, 2010. Continue to carry out such program in compliance with [§ 195.440](#).
 - (8) Establish a damage prevention program in compliance with [§ 195.442](#) before transportation begins, or if the pipeline exists on July 3, 2008, before July 3, 2009. Continue to carry out such program in compliance with [§ 195.442](#).
 - (9) For steel pipelines, comply with [subpart H](#) of this part, except corrosion control is not required for pipelines existing on July 3, 2008 before July 3, 2011.
 - (10) For steel pipelines, establish and follow a comprehensive and effective program to continuously identify operating conditions that could contribute to internal corrosion. The program must include measures to prevent and mitigate internal corrosion, such as cleaning the pipeline and using inhibitors. This program must be established before transportation begins or if the pipeline exists on July 3, 2008, before July 3, 2009.
 - (11) To comply with the Operator Qualification program requirements in [subpart G](#) of this part, have a written description of the processes used to carry out the requirements in [§ 195.505](#) to

determine the qualification of persons performing operations and maintenance tasks. These processes must be established before transportation begins or if the pipeline exists on July 3, 2008, before July 3, 2009.

- (c) *New unusually sensitive areas.* If, after July 3, 2008, a new unusually sensitive area is identified and a segment of pipeline becomes regulated as a result, except for the requirements of paragraphs (b)(9) and (b)(10) of this section, the operator must implement the requirements in paragraphs (b)(2) through (b)(11) of this section for the affected segment within 6 months of identification. For steel pipelines, comply with the deadlines in paragraph (b)(9) and (b)(10).
- (d) *Record Retention.* An operator must maintain records demonstrating compliance with each requirement according to the following schedule.
 - (1) An operator must maintain the segment identification records required in paragraph (b)(1) of this section and the records required to comply with (b)(10) of this section, for the life of the pipe.
 - (2) An operator must maintain the records necessary to demonstrate compliance with each requirement in paragraphs (b)(2) through (b)(9), and (b)(11) of this section according to the record retention requirements of the referenced section or subpart.

[Amdt. 195-89, 73 FR 31634, June 3, 2008; Amdt. 195-105, 87 FR 20940, Apr. 8, 2022; Amdt. 195-106, 88 FR 50056, Aug. 1, 2023]

§195.10 Responsibility of operator for compliance with this part.

An operator may make arrangements with another person for the performance of any action required by this part. However, the operator is not thereby relieved from the responsibility for compliance with any requirement of this part.

§195.12 What requirements apply to low-stress pipelines in rural areas?

- (a) General. This Section sets forth the requirements for each category of low-stress pipeline in a rural area set forth in paragraph (b) of this Section. This Section does not apply to a rural low-stress pipeline regulated under this Part as a low-stress pipeline that crosses a waterway currently used for commercial navigation; these pipelines are regulated pursuant to § [195.1\(a\)\(2\)](#).
- (b) Categories. An operator of a rural low-stress pipeline must meet the applicable requirements and compliance deadlines for the category of pipeline set forth in paragraph (c) of this Section. For purposes of this Section, a rural low-stress pipeline is a Category 1, 2, or 3 pipeline based on the following criteria:
 - (1) A Category 1 rural low-stress pipeline:
 - (i) Has a nominal diameter of 8 5/8 inches (219.1 mm) or more;
 - (ii) Is located in or within one-half mile (.80 km) of an unusually sensitive area (USA) as defined in § [195.6](#); and
 - (iii) Operates at a maximum pressure established under § [195.406](#) corresponding to:
 - (A) A stress level equal to or less than 20-percent of the specified minimum yield strength of the line pipe; or

- (B) If the stress level is unknown or the pipeline is not constructed with steel pipe, a pressure equal to or less than 125 psi (861 kPa) gauge.
- (2) A Category 2 rural pipeline:
- (i) Has a nominal diameter of less than 8 5/8 inches (219.1mm);
 - (ii) Is located in or within one-half mile (.80 km) of an unusually sensitive area (USA) as defined in § [195.6](#); and
 - (iii) Operates at a maximum pressure established under § [195.406](#) corresponding to:
 - (A) A stress level equal to or less than 20-percent of the specified minimum yield strength of the line pipe; or
 - (B) If the stress level is unknown or the pipeline is not constructed with steel pipe, a pressure equal to or less than 125 psi (861 kPa) gage.
- (3) A Category 3 rural low-stress pipeline:
- (i) Has a nominal diameter of any size and is not located in or within one-half mile (.80 km) of an unusually sensitive area (USA) as defined in § [195.6](#); and
 - (ii) Operates at a maximum pressure established under § [195.406](#) corresponding to a stress level equal to or less than 20-percent of the specified minimum yield strength of the line pipe; or
 - (iii) If the stress level is unknown or the pipeline is not constructed with steel pipe, a pressure equal to or less than 125 psi (861 kPa) gage.
- (c) Applicable requirements and deadlines for compliance. An operator must comply with the following compliance dates depending on the category of pipeline determined by the criteria in paragraph (b):
- (1) An operator of a Category 1 pipeline must:
- (i) Identify all segments of pipeline meeting the criteria in paragraph (b)(1) of this Section before April 3, 2009.
 - (ii) Beginning no later than January 3, 2009, comply with the reporting requirements of [Subpart B](#) for the identified segments.
 - (iii) IM requirements -
 - (A) Establish a written program that complies with § 195.452 before July 3, 2009, to assure the integrity of the pipeline segments. Continue to carry out such program in compliance with § 195.452.
 - (B) An operator may conduct a determination per § 195.452(a) in lieu of the one-half mile buffer.
 - (C) Complete the baseline assessment of all segments in accordance with § 195.452(c) before July 3, 2015, and complete at least 50- percent of the assessments, beginning with the highest risk pipe, before January 3, 2012.
 - (iv) Comply with all other safety requirements of this Part, except [Subpart H](#), before July 3, 2009. Comply with the requirements of [Subpart H](#) before July 3, 2011.
- (2) An operator of a Category 2 pipeline must:
- (i) Identify all segments of pipeline meeting the criteria in paragraph (b)(2) of this Section before July 1, 2012.
 - (ii) Beginning no later than January 3, 2009, comply with the reporting requirements of [Subpart B](#) for the identified segments.

(iii) IM -

- (A) Establish a written IM program that complies with § 195.452 before October 1, 2012 to assure the integrity of the pipeline segments. Continue to carry out such program in compliance with § 195.452.
- (B) An operator may conduct a determination per § 195.452(a) in lieu of the one-half mile buffer.
- (C) Complete the baseline assessment of all segments in accordance with § 195.452(c) before October 1, 2016 and complete at least 50 percent of the assessments, beginning with the highest risk pipe, before April 1, 2014.

(iv) Comply with all other safety requirements of this Part, except [Subpart H](#), before October 1, 2012. Comply with Subpart H of this Part before October 1, 2014.

(3) An operator of a Category 3 pipeline must:

- (i) Identify all segments of pipeline meeting the criteria in paragraph (b)(3) of this Section before July 1, 2012.
- (ii) Beginning no later than January 3, 2009, comply with the reporting requirements of [Subpart B](#) for the identified segments.
- (A)(iii) Comply with all safety requirements of this Part, except the requirements in § 195.452, Subpart B, and the requirements in [Subpart H](#), before October 1, 2012. Comply with [Subpart H](#) of this Part before October 1, 2014.

(d) Economic compliance burden.

(1) An operator may notify PHMSA in accordance with § 195.452(m) of a situation meeting the following criteria:

- (i) The pipeline is a Category 1 rural low-stress pipeline;
- (ii) The pipeline carries crude oil from a production facility;
- (iii) The pipeline, when in operation, operates at a flow rate less than or equal to 14,000 barrels per day; and
- (iv) The operator determines it would abandon or shut-down the pipeline as a result of the economic burden to comply with the assessment requirements in § 195.452(d) or 195.452(j).

(2) A notification submitted under this provision must include, at minimum, the following information about the pipeline: its operating, maintenance and leak history; the estimated cost to comply with the integrity assessment requirements (with a brief description of the basis for the estimate); the estimated amount of production from affected wells per year, whether wells will be shut in or alternate transportation used, and if alternate transportation will be used, the estimated cost to do so.

(3) When an operator notifies PHMSA in accordance with paragraph (d)(1) of this Section, PHMSA will stay compliance with § § 195.452(d) and 195.452(j)(3) until it has completed an analysis of the notification. PHMSA will consult the Department of Energy, as appropriate, to help analyze the potential energy impact of loss of the pipeline. Based on the analysis, PHMSA may grant the operator a special permit to allow continued operation of the pipeline subject to alternative safety requirements.

(e) Changes in unusually sensitive areas.

- (1) If, after June 3, 2008, for Category 1 rural low-stress pipelines or October 1, 2011 for Category 2 rural low-stress pipelines, an operator identifies a new USA that causes a segment of pipeline to meet the criteria in paragraph (b) of this Section as a Category 1 or Category 2 rural low-stress pipeline, the operator must:
 - (i) Comply with the IM program requirement in paragraph (c)(1)(iii)(A) or (c)(2)(iii)(A) of this Section, as appropriate, within 12 months following the date the area is identified regardless of the prior categorization of the pipeline; and
 - (ii) Complete the baseline assessment required by paragraph (c)(1)(iii)(C) or (c)(2)(iii)(C) of this Section, as appropriate, according to the schedule in § 195.452(d)(3).
 - (2) If a change to the boundaries of a USA causes a Category 1 or Category 2 pipeline segment to no longer be within one-half mile of a USA, an operator must continue to comply with paragraph (c)(1)(iii) or paragraph (c)(2)(iii) of this section, as applicable, with respect to that segment unless the operator determines that a release from the pipeline could not affect the USA.
- (f) Record Retention. An operator must maintain records demonstrating compliance with each requirement applicable to the category of pipeline according to the following schedule.
- (1) An operator must maintain the segment identification records required in paragraph (c)(1)(i), (c)(2)(i) or (c)(3)(i) of this Section for the life of the pipe.
 - (2) Except for the segment identification records, an operator must maintain the records necessary to demonstrate compliance with each applicable requirement set forth in paragraph (c) of this Section according to the record retention requirements of the referenced Section or Subpart.

[76 FR 25587, May 5, 2011, as amended at 76 FR 43605, July 21, 2011]

§195.13 What requirements apply to pipelines transporting hazardous liquids by gravity?

- (a) *Scope.* Pipelines transporting hazardous liquids by gravity must comply with the reporting requirements of [subpart B](#) of this part.
- (b) *Implementation period -*
 - (1) *Annual reporting.* Comply with the annual reporting requirements in subpart B of this part by March 31, 2021.
 - (2) *Accident and safety-related reporting.* Comply with the accident and safety-related condition reporting requirements in [subpart B](#) of this part by January 1, 2021.
- (c) *Exceptions.*
 - (1) This section does not apply to the transportation of a hazardous liquid in a gravity line that meets the definition of a low-stress pipeline, travels no farther than 1 mile from a facility boundary, and does not cross any waterways used for commercial navigation.
 - (2) The reporting requirements in §§[195.52](#), [195.61](#), and [195.65](#) do not apply to the transportation of a hazardous liquid in a gravity line.
 - (3) The drug and alcohol testing requirements in part 199 of this subchapter do not apply to the transportation of a hazardous liquid in a gravity line.

[Amdt. 195-102, 84 FR 52294, Oct. 1, 2019]

§195.15 What requirements apply to reporting-regulated-only gathering lines?

- (a) *Scope.* Gathering lines that do not otherwise meet the definition of a regulated rural gathering line in §195.11 and any gathering line not already covered under §[195.1](#)(a)(1), (2), (3) or (4) must comply with the reporting requirements of [subpart B](#) of this part.
- (b) *Implementation period -*
- (1) *Annual reporting.* Operators must comply with the annual reporting requirements in subpart B of this part by March 31, 2021.
 - (2) *Accident and safety-related condition reporting.* Operators must comply with the accident and safety-related condition reporting requirements in [subpart B](#) of this part by January 1, 2021.
- (c) *Exceptions.*
- (1) This section does not apply to those gathering lines that are otherwise excepted under §[195.1](#)(b)(3), (7), (8), (9), or (10).
 - (2) The reporting requirements in §§[195.52](#), [195.61](#), and [195.65](#) do not apply to the transportation of a hazardous liquid in a gathering line that is specified in paragraph (a) of this section.
 - (3) The drug and alcohol testing requirements in part 199 of this subchapter do not apply to the transportation of a hazardous liquid in a gathering line that is specified in paragraph (a) of this section.

[Amdt. 195-102, 84 FR 52294, Oct. 1, 2019]

§195.18 How to notify PHMSA.

- (a) An operator must provide any notification required by this part by:
- (1) Sending the notification by electronic mail to InformationResourcesManager@dot.gov; or
 - (2) Sending the notification by mail to ATTN: Information Resources Manager, DOT/PHMSA/OPS, East Building, 2nd Floor, E22-321, 1200 New Jersey Ave. SE, Washington, DC 20590.
- (b) An operator must also notify the appropriate State or local pipeline safety authority when an applicable pipeline segment is located in a State where OPS has an interstate agent agreement, or an intrastate pipeline segment is regulated by that State.
- (c) Unless otherwise specified, if an operator submits, pursuant to § [195.258](#), § [195.260](#), § [195.418](#), § [195.419](#), § [195.420](#) or § [195.452](#) a notification requesting use of a different integrity assessment method, analytical method, sampling approach, compliance timeline, or technique (e.g., “other technology” or “alternative equivalent technology”) than otherwise prescribed in those sections, that notification must be submitted to PHMSA for review at least 90 days in advance of using that other method, approach, compliance timeline, or technique. An operator may proceed to use the other method, approach, compliance timeline, or technique 91 days after submittal of the notification unless it receives a letter from the Associate Administrator of Pipeline Safety informing the operator that PHMSA objects to the proposal, or that PHMSA requires additional time and/or information to conduct its review.

[Amdt. 195-105, 87 FR 20940, Apr. 8, 2022]

SubPart B - Annual, Accident, and Safety-Related Condition Reporting (§§48-65)

SubPart B - Annual, Accident, and Safety-Related Condition Reporting

- §195.48 [Scope](#)
- §195.49 [Annual report](#)
- §195.50 [Reporting accidents.](#)
- §195.52 [Telephonic notice of certain accidents.](#)
- §195.54 [Accident reports.](#)
- §195.55 [Reporting safety-related conditions.](#)
- §195.56 [Filing safety-related condition reports.](#)
- §195.57 [Filing offshore pipeline condition reports.](#)
- §195.58 [Addressee for written reports.](#)
- §195.59 [Abandonment or deactivation of facilities.](#)
- §195.60 [Operator assistance in investigation.](#)
- §195.61 [National Pipeline Mapping System](#)
- §195.62 [Supplies of Accident Report DOT Form 7000-1](#)
- §195.63 [OMB control number assigned to information collection.](#)
- §195.64 [National Registry of Operators.](#)
- §195.65 [Safety data sheets.](#)

§195.48 Scope.

This Subpart prescribes requirements for periodic reporting and for reporting of accidents and safety-related conditions. This Subpart applies to all pipelines subject to this Part. An operator of a Category 3 rural low-stress pipeline meeting the criteria in § [195.12](#) is not required to complete those parts of the hazardous liquid annual report form PHMSA F 7000-1.1 associated with IM or high consequence areas.

[76 FR 25588, May 5, 2011]

§195.49 Annual report.

Each operator must annually complete and submit DOT Form PHMSA F 7000-1.1 for each type of hazardous liquid pipeline facility operated at the end of the previous year. An operator must submit the annual report by June 15 each year, except that for the 2010 reporting year the report must be submitted by August 15, 2011. A separate report is required for crude oil, HVL (including anhydrous ammonia), petroleum products, carbon dioxide pipelines, and fuel grade ethanol pipelines. For each state a pipeline traverses, an operator must separately complete those sections on the form requiring information to be reported for each state.

[75 FR 72907, Nov. 26, 2010]

§195.50 Reporting accidents.

An accident report is required for each failure in a pipeline system subject to this part in which there is a release of the hazardous liquid or carbon dioxide transported resulting in any of the following:

- (a) Explosion or fire not intentionally set by the operator.
- (b) Release of 5 gallons (19 liters) or more of hazardous liquid or carbon dioxide, except that no report is required for a release of less than 5 barrels (0.8 cubic meters) resulting from a pipeline maintenance activity if the release is:
 - (1) Not otherwise reportable under this section;
 - (2) Not one described in § [195.52\(a\)\(4\)](#);
 - (3) Confined to company property or pipeline right-of-way; and
 - (4) Cleaned up promptly;
- (c) Death of any person;
- (d) Personal injury necessitating hospitalization;
- (e) Estimated property damage, including cost of clean-up and recovery, value of lost product, and damage to the property of the operator or others, or both, exceeding \$50,000.

[Amdt. 195-22, 46 FR 38360, July 27, 1981, as amended by Amdt. 195-39, 53 FR 24950, July 1, 1988; Amdt. 195-45, 56 FR 26925, June 12, 1991; Amdt. 195-52, 59 FR 33396, June 28, 1994; Amdt. 195-63, 63 FR 37506, July 13, 1998; Amdt. 195-75, 67 FR 836, Jan. 8, 2002]

§195.52 Immediate notice of certain accidents.

- (a) Notice requirements. At the earliest practicable moment following discovery, of a release of the hazardous liquid or carbon dioxide transported resulting in an event described in § [195.50](#), but no later than one hour after confirmed discovery, the operator of the system must give notice, in accordance with paragraph (b) of this section of any failure that:
 - (1) Caused a death or a personal injury requiring hospitalization;
 - (2) Resulted in either a fire or explosion not intentionally set by the operator;
 - (3) Caused estimated property damage, including cost of cleanup and recovery, value of lost product, and damage to the property of the operator or others, or both, exceeding \$50,000;
 - (4) Resulted in pollution of any stream, river, lake, reservoir, or other similar body of water that violated applicable water quality standards, caused a discoloration of the surface of the water or adjoining shoreline, or deposited a sludge or emulsion beneath the surface of the water or upon adjoining shorelines; or
 - (5) In the judgment of the operator was significant even though it did not meet the criteria of any other paragraph of this section.
- (b) Information required. Each notice required by paragraph (a) of this section must be made to the National Response Center either by telephone to 800-424-8802 (in Washington, DC, 202-267-2675) or electronically at <http://www.nrc.uscg.mil> and must include the following information:
 - (1) Name, address and identification number of the operator.
 - (2) Name and telephone number of the reporter.
 - (3) The location of the failure.
 - (4) The time of the failure.
 - (5) The fatalities and personal injuries, if any.
 - (6) Initial estimate of amount of product released in accordance with paragraph (c) of this section.
 - (7) All other significant facts known by the operator that are relevant to the cause of the failure or extent of the damages.

- (c) Calculation. A pipeline operator must have a written procedure to calculate and provide a reasonable initial estimate of the amount of released product.
- (d) New information. Within 48 hours after the confirmed discovery of an accident, to the extent practicable, an operator must revise or confirm its initial telephonic notice required in paragraph (b) of this section with a revised estimate of the amount of product released, location of the failure, time of the failure, a revised estimate of the number of fatalities and injuries, and all other significant facts that are known by the operator that are relevant to the cause of the accident or extent of the damages. If there are no changes or revisions to the initial report, the operator must confirm the estimates in its initial report.

[75 FR 72907, Nov. 26, 2010, as amended by Amdt. 195-101, 82 FR 7999, Jan. 23, 2017]

§195.54 Accident reports.

- (a) Each operator that experiences an accident that is required to be reported under § [195.50](#) must, as soon as practicable, but not later than 30 days after discovery of the accident, file an accident report on DOT Form 7000-1.
- (b) Whenever an operator receives any changes in the information reported or additions to the original report on [DOT Form 7000-1](#), it shall file a supplemental report within 30 days.

[Amdt. 195-39, 53 FR 24950, July 1, 1988, as amended by Amdt. 195-95, 75 FR 72907, Nov. 26, 2010]

§195.55 Reporting safety-related conditions.

- (a) Except as provided in paragraph (b) of this section, each operator shall report in accordance with [§195.56](#) the existence of any of the following safety-related conditions involving pipelines in service:
 - (1) General corrosion that has reduced the wall thickness to less than that required for the maximum operating pressure, and localized corrosion pitting to a degree where leakage might result.
 - (2) Unintended movement or abnormal loading of a pipeline by environmental causes, such as an earthquake, landslide, or flood, that impairs its serviceability.
 - (3) Any material defect or physical damage that impairs the serviceability of a pipeline.
 - (4) Any malfunction or operating error that causes the pressure of a pipeline to rise above 110 percent of its maximum operating pressure.
 - (5) A leak in a pipeline that constitutes an emergency.
 - (6) Any safety-related condition that could lead to an imminent hazard and causes (either directly or indirectly by remedial action of the operator), for purposes other than abandonment, a 20 percent or more reduction in operating pressure or shutdown of operation of a pipeline.
- (b) A report is not required for any safety-related condition that-
 - (1) Exists on a pipeline that is more than 220 yards (200 meters) from any building intended for human occupancy or outdoor place of assembly, except that reports are required for conditions within the right-of-way of an active railroad, paved road, street, or highway, or that occur offshore or at onshore locations where a loss of hazardous liquid could reasonably be expected to pollute any stream, river, lake, reservoir, or other body of water;

- (2) Is an accident that is required to be reported under [§195.50](#) or results in such an accident before the deadline for filing the safety-related condition report; or
- (3) Is corrected by repair or replacement in accordance with applicable safety standards before the deadline for filing the safety-related condition report, except that reports are required for all conditions under paragraph (a)(1) of this section other than localized corrosion pitting on an effectively coated and cathodically protected pipeline.

[Amdt. 195-39, 53 FR 24950, July 1, 1988; 53 FR 29800, Aug. 8, 1988, as amended by Amdt. 195-63, 63 FR 37506, July 13, 1998]

§195.56 Filing safety-related condition reports.

- (a) Each report of a safety-related condition under [§195.55\(a\)](#) must be filed (received by OPS) within 5 working days (not including Saturday, Sunday, or Federal Holidays) after the day a representative of the operator first determines that the condition exists, but not later than 10 working days after the day a representative of the operator discovers the condition. Separate conditions may be described in a single report if they are closely related. Reports may be transmitted by electronic mail to InformationResourcesManager@dot.gov, or by facsimile at (202) 366-7128.
- (b) The report must be headed "Safety-Related Condition Report" and provide the following information:
 - (1) Name and principal address of operator.
 - (2) Date of report.
 - (3) Name, job title, and business telephone number of person submitting the report.
 - (4) Name, job title, and business telephone number of person who determined that the condition exists.
 - (5) Date condition was discovered and date condition was first determined to exist.
 - (6) Location of condition, with reference to the State (and town, city, or county) or offshore site, and as appropriate nearest street address, offshore platform, survey station number, milepost, landmark, or name of pipeline.
 - (7) Description of the condition, including circumstances leading to its discovery, any significant effects of the condition on safety, and the name of the commodity transported or stored.
 - (8) The corrective action taken (including reduction of pressure or shutdown) before the report is submitted and the planned follow-up or future corrective action, including the anticipated schedule for starting and concluding such action.

[Amdt. 195-39, 53 FR 24950, July 1, 1988; 53 FR 29800, Aug. 8, 1988, as amended by Amdt. 195-42, 54 FR 32344, Aug. 7, 1989; Amdt. 195-44, 54 FR 40878, Oct. 4, 1989; Amdt. 195-50, 59 FR 17281, Apr. 12, 1994; Amdt. 195-61, 63 FR 7723, Feb. 17, 1998; Amdt. 195-100, 80 FR 12780, Mar. 11, 2015]

§195.57 Removed

[Removed]

§195.58 Report submission requirements.

This section has been amended by Amdt. 195-107, eff. 6/28/24.

- (a) General. Except as provided in paragraphs (b) and (e) of this section, an operator must submit each report required by this part electronically to PHMSA at <https://portal.phmsa.dot.gov> unless an alternative reporting method is authorized in accordance with paragraph (d) of this section.
- (b) *Exceptions*: An operator is not required to submit a safety- related condition report (§ [195.56](#)) electronically.
- (c) *Safety-related conditions*. An operator must submit concurrently to the applicable State agency a safety-related condition report required by § [195.55](#) for an interstate pipeline or when the State agency acts as an agent of the Secretary with respect to intrastate pipelines.
- (d) *Alternate Reporting Method*. If electronic reporting imposes an undue burden and hardship, the operator may submit a written request for an alternative reporting method to the Information Resources Manager, Office of Pipeline Safety, Pipeline and Hazardous Materials Safety Administration, PHP-20, 1200 New Jersey Avenue, SE., Washington DC 20590. The request must describe the undue burden and hardship. PHMSA will review the request and may authorize, in writing, an alternative reporting method. An authorization will state the period for which it is valid, which may be indefinite. An operator must contact PHMSA at 202-366-8075, or electronically to "informationresourcesmanager@dot.gov" to make arrangements for submitting a report that is due after a request for alternative reporting is submitted but before an authorization or denial is received.

[34 FR 15473, Oct. 4, 1969 as amended by Amdt. 195-5, 38 FR 2977, Jan. 31, 1973; Amdt. 195-22, 46 FR 38357, July 27, 1981, Amdt. 195-23, 47 FR 32719, July 29, 1982; Amdt. 195-34, 50 FR 34470, August 26, 1985; Amdt. 195-39, 53 FR 24942, July 1, 1988; Amdt. 195-50, 59 FR 17275, Apr. 12, 1994, Amdt. 195-55, 61 FR 18512, Apr. 26, 1996; Amdt. 195-81, 69 FR 32886, Apr 23, 2004; ; No Number, 70 FR 11135, Mar. 8, 2005; Amdt. 195-90, 74 FR 2889, Jan. 16, 2009; Amdt. 195-95, 75 FR 72877, Nov. 26, 2010; Amdt. 195-100, 80 FR 12762, Mar. 11, 2015; Amdt. 195-107, 89 FR 33264, Apr. 29, 2024]

§195.59 Abandonment or deactivation of facilities.

This section has been amended by Amdt. 195-107, eff. 6/28/24.

For each abandoned offshore pipeline facility or each abandoned onshore pipeline facility that crosses over, under or through a commercially navigable waterway, the last operator of that facility must file a report upon abandonment of that facility.

- (a) The preferred method to submit data on pipeline facilities abandoned after October 10, 2000, is to the National Pipeline Mapping System (NPMS) in accordance with the NPMS “Standards for Pipeline and Liquefied Natural Gas Operator Submissions.” To obtain a copy of the NPMS standards, please refer to the NPMS homepage at <https://www.npms.phmsa.dot.gov>. A digital data format is preferred, but hard copy submissions are acceptable if they comply with the NPMS Standards. In addition to the NPMS-required attributes, operators must submit the date of abandonment, diameter, method of abandonment, and certification that, to the best of the operator's knowledge, all of the reasonably available information requested was provided and, to the best of the operator's knowledge, the abandonment was completed in accordance with applicable laws. Refer to the NPMS Standards for details in preparing your data for submission. The NPMS Standards also include details of how to submit data. Alternatively, operators may submit reports by mail, fax or email to the Office of Pipeline Safety, Pipeline and Hazardous Materials Safety Administration, U.S. Department of Transportation, Information Resources Manager, PHP-10, 1200 New Jersey Avenue SE, Washington, DC 20590-0001; fax: (202) 366-4566; email: InformationResourcesManager@dot.gov. The information in the report must contain all reasonably

available information related to the facility, including information in the possession of a third party. The report must contain the location, size, date, method of abandonment, and a certification that the facility has been abandoned in accordance with all applicable laws.

(b) [Reserved].

[Amdt. 195-69, 65 FR 54444, Sept. 8, 2000, as amended at 70 FR 11140, Mar. 8, 2005; Amdt. 195-86, 72 FR 4657, Feb. 1, 2007; 73 FR 16570, Mar. 28, 2008; 74 FR 2894, Jan. 16, 2009; Amdt. 195-107, 89 FR 33264, Apr. 29, 2024]

§195.60 Operator assistance in investigation.

If the Department of Transportation investigates an accident, the operator involved shall make available to the representative of the Department all records and information that in any way pertain to the accident, and shall afford all reasonable assistance in the investigation of the accident.

§195.61 National Pipeline Mapping System.

- (a) Each operator of a hazardous liquid pipeline facility must provide the following geospatial data to PHMSA for that facility:
- (1) Geospatial data, attributes, metadata and transmittal letter appropriate for use in the National Pipeline Mapping System. Acceptable formats and additional information are specified in the NPMS Operator Standards manual available at www.npms.phmsa.dot.gov or by contacting the PHMSA Geographic Information Systems Manager at (202) 366-4595.
 - (2) The name of and address for the operator.
 - (3) The name and contact information of a pipeline company employee, to be displayed on a public Web site, who will serve as a contact for questions from the general public about the operator's NPMS data.
- (b) This information must be submitted each year, on or before June 15, representing assets as of December 31 of the previous year. If no changes have occurred since the previous year's submission, the operator must refer to the information provided in the NPMS Operator Standards manual available at www.npms.phmsa.dot.gov or contact the PHMSA Geographic Information Systems Manager at (202) 366-4595.

[Amdt. 195-100, 80 FR 12780, Mar. 11, 2015]

§195.62 [Removed]

[34 FR 15473, Oct. 4, 1969 as amended by Amdt 195-5, 38 FR 2977, Jan. 31, 1973; Amdt. 195-22, 46 FR 38357, July 27, 1981; Amdt.195-23, 47 FR 32719, July 29, 1982; 192-90, 74 FR 2889, January 16, 2009; Amdt. 195-95, 75 FR 72877, November 26, 2010]

§195.63 OMB control number assigned to information collection.

The control numbers assigned by the Office of Management and Budget to the hazardous liquid pipeline information collection pursuant to the Paperwork Reduction Act are 2137-0047, 2137-0601, 2137-0604, 2137-0605, 2137-0618, and 2137-0622.

[Amdt. 195-95, 75 FR 72907, Nov. 26, 2010]

§195.64 National Registry of Operators.

- (a) *OPID Request.* Effective January 1, 2012, each operator of a hazardous liquid or carbon dioxide pipeline or pipeline facility must obtain from PHMSA an Operator Identification Number (OPID). An OPID is assigned to an operator for the pipeline or pipeline system for which the operator has primary responsibility. To obtain an OPID or a change to an OPID, an operator must complete an OPID Assignment Request DOT Form PHMSA F 1000.1 through the National Registry of Operators in accordance with § [195.58](#).
- (b) *OPID validation.* An operator who has already been assigned one or more OPID by January 1, 2011 must validate the information associated with each such OPID through the National Registry of Operators at <https://portal.phmsa.dot.gov>, and correct that information as necessary, no later than June 30, 2012.
- (c) *Changes.* Each operator must notify PHMSA electronically through the National Registry of Operators at <https://portal.phmsa.dot.gov>, of certain events.
- (1) An operator must notify PHMSA of any of the following events not later than 60 days before the event occurs:
- (i) Construction or any planned rehabilitation, replacement, modification, upgrade, uprate, or update of a facility, other than a section of line pipe, that costs \$10 million or more. If 60 day notice is not feasible because of an emergency, an operator must notify PHMSA as soon as practicable;
 - (ii) Construction of 10 or more miles of a new or replacement hazardous liquid or carbon dioxide pipeline;
 - (iii) Reversal of product flow direction when the reversal is expected to last more than 30 days. This notification is not required for pipeline systems already designed for bi-directional flow; or
 - (iv) A pipeline converted for service under § [195.5](#), or a change in commodity as reported on the annual report as required by § [195.49](#).
- (2) An operator must notify PHMSA of any following event not later than 60 days after the event occurs:
- (i) A change in the primary entity responsible (i.e., with an assigned OPID) for managing or administering a safety program required by this part covering pipeline facilities operated under multiple OPIDs.
 - (ii) A change in the name of the operator;
 - (iii) A change in the entity (e.g., company, municipality) responsible for operating an existing pipeline, pipeline segment, or pipeline facility;
 - (iv) The acquisition or divestiture of 50 or more miles of pipeline or pipeline system subject to this part; or
 - (v) The acquisition or divestiture of an existing pipeline facility subject to this part.

(d) *Reporting.* An operator must use the OPID issued by PHMSA for all reporting requirements covered under this subchapter and for submissions to the National Pipeline Mapping System.

[Amdt. 195-95, 75 FR 72907, Nov. 26, 2010, as amended by Amdt. 195-100, 80 FR 12780, Mar. 11, 2015; Amdt. 195-101, 82 FR 7999, Jan. 23, 2017; Amdt. 195-103, 85 FR 8127, Feb. 12, 2020]

§195.65 Safety data sheets.

(a) Each owner or operator of a hazardous liquid pipeline facility, following an accident involving a pipeline facility that results in a hazardous liquid spill, must provide safety data sheets on any spilled hazardous liquid to the designated Federal On-Scene Coordinator and appropriate State and local emergency responders within 6 hours of a telephonic or electronic notice of the accident to the National Response Center.

(b) *Definitions.* In this section:

- (1) *Federal On-Scene Coordinator.* The term "Federal On-Scene Coordinator" has the meaning given such term in section 311(a) of the Federal Water Pollution Control Act (33 U.S.C. 1321(a)).
- (2) *National Response Center.* The term "National Response Center" means the center described under 40 CFR 300.125(a).
- (3) *Safety data sheet.* The term "safety data sheet" means a safety data sheet required under 29 CFR 1910.1200.

[Amdt. 195-102, 84 FR 52294, Oct. 1, 2019]

Subpart C - Design Requirements (§§100-134)

SubPart C - Design Requirements

- 195.100 [Scope.](#)
- 195.101 [Qualifying metallic components other than pipe.](#)
- 195.102 [Design temperature.](#)
- 195.104 [Variations in pressure.](#)
- 195.106 [Internal design pressure.](#)
- 195.108 [External pressure.](#)
- 195.110 [External loads.](#)
- 195.111 [Fracture propagation.](#)
- 195.112 [New pipe.](#)
- 195.114 [Used pipe.](#)
- 195.116 [Valves.](#)
- 195.118 [Fittings.](#)
- 195.120 [Passage of internal inspection devices.](#)
- 195.122 [Fabricated branch connections.](#)
- 195.124 [Closures.](#)
- 195.126 [Flange connection.](#)
- 195.128 [Station piping.](#)
- 195.130 [Fabricated assemblies.](#)
- 195.132 [Aboveground breakout tanks.](#)
- 195.134 [Leak detection](#)

§195.100 Scope.

This subpart prescribes minimum design requirements for new pipeline systems constructed with steel pipe and for relocating, replacing, or otherwise changing existing systems constructed with steel pipe. However, it does not apply to the movement of line pipe covered by [§195.424](#).

§195.101 Qualifying metallic components other than pipe.

Notwithstanding any requirement of the subpart which incorporates by reference an edition of a document listed in [§195.3](#), a metallic component other than pipe manufactured in accordance with any other edition of that document is qualified for use if-

- (a) It can be shown through visual inspection of the cleaned component that no defect exists which might impair the strength or tightness of the component: and
- (b) The edition of the document under which the component was manufactured has equal or more stringent requirements for the following as an edition of that document currently or previously listed in [§195.3](#):
 - (1) Pressure testing;
 - (2) Materials; and
 - (3) Pressure and temperature ratings.

[Amdt. 195-28, 48 FR 30639, July 5, 1983]

§195.102 Design temperature.

- (a) Material for components of the system must be chosen for the temperature environment in which the components will be used so that the pipeline will maintain its structural integrity.
- (b) Components of carbon dioxide pipelines that are subject to low temperatures during normal operation because of rapid pressure reduction or during the initial fill of the line must be made of materials that are suitable for those low temperatures.

[Amdt. 195-45, 56 FR 26925, June 12, 1991]

§195.104 Variations in pressure.

If, within a pipeline system, two or more components are to be connected at a place where one will operate at a higher pressure than another, the system must be designed so that any component operating at the lower pressure will not be overstressed.

§195.106 Internal design pressure.

This section has been amended by Amdt. 195-107, eff. 6/28/24.

- (a) Internal design pressure for the pipe in a pipeline is determined in accordance with the following formula:

$$P = (2 St/D) \times E \times F$$

P = Internal design pressure in p.s.i. (kPa) gage.

S = Yield strength in pounds per square inch (kPa) determined in accordance with paragraph (b) of this section.

t = Nominal wall thickness of the pipe in inches (millimeters). If this is unknown, it is determined in accordance with paragraph (c) of this section.

D = Nominal outside diameter of the pipe in inches (millimeters).

E = Seam joint factor determined in accordance with paragraph (e) of this section.

F = A design factor of 0.72, except that a design factor of 0.60 is used for pipe, including risers, on a platform located offshore or on a platform in inland navigable waters, and 0.54 is used for pipe that has been subjected to cold expansion to meet the specified minimum yield strength and is subsequently heated, other than by welding or stress relieving as a part of welding, to a temperature higher than 900°F (482°C) for any period of time or over 600°F (316°C) for more than 1 hour.

- (b) The yield strength to be used in determining the internal design pressure under paragraph (a) of this section is the specified minimum yield strength. If the specified minimum yield strength is not known, the yield strength to be used in the design formula is one of the following:

(1)

- (i) The yield strength determined by performing all of the tensile tests of API Spec 5L (incorporated by reference, see [§195.3](#)) on randomly selected specimens with the following number of tests:

Pipe Size	No. of Tests
Less than 6 5/8 in (168 mm) nominal outside diameter.	One test for each 200 lengths.
6 5/8 in through 12 3/4 in (168 mm through 324 mm) nominal outside diameter.	One test for each 100 lengths.
Larger than 12 3/4 in (324 mm) nominal outside diameter.	One test for each 50 lengths.

(ii) If the average yield-tensile ratio exceeds 0.85, the yield strength shall be taken as 24,000 p.s.i. (165, 474 kPa). If the average yield-tensile ratio is 0.85 or less, the yield strength of the pipe is taken as the lower of the following:

- (A) Eighty percent of the average yield strength determined by the tensile tests.
- (B) The lowest yield strength determined by the tensile tests.

(2) If the pipe is not tensile tested as provided in paragraph (b) of this section, the yield strength shall be taken as 24,000 p.s.i. (165,474 kPa).

- (c) If the nominal wall thickness to be used in determining internal design pressure under paragraph (a) of this section is not known, it is determined by measuring the thickness of each piece of pipe at quarter points on one end. However, if the pipe is of uniform grade, size, and thickness, only 10 individual lengths or 5 percent of all lengths, whichever is greater, need be measured. The thickness of the lengths that are not measured must be verified by applying a gage set to the minimum thickness found by the measurement. The nominal wall thickness to be used is the next wall thickness found in commercial specifications that is below the average of all the measurements taken. However, the nominal wall thickness may not be more than 1.14 times the smallest measurement taken on pipe that is less than 20 inches (508 mm) nominal outside diameter, nor more than 1.11 times the smallest measurement taken on pipe that is 20 inches (508 mm) or more in nominal outside diameter.
- (d) The minimum wall thickness of the pipe may not be less than 87.5 percent of the value used for nominal wall thickness in determining the internal design pressure under paragraph (a) of this section. In addition, the anticipated external loads and external pressures that are concurrent with internal pressure must be considered in accordance with §§[195.108](#) and [195.110](#) and, after determining the internal design pressure, the nominal wall thickness must be increased as necessary to compensate for these concurrent loads and pressures.
- (e) (1) The seam joint factor used in paragraph (a) of this section is determined in accordance with the following standards incorporated by reference (see §[195.3](#)):

Specification	Pipe class	Seam joint factor
ASTM A53/A53M	Seamless	1.00
	Electric resistance welded	1.00
	Furnace lap welded	0.80
	Furnace butt welded	0.60
ASTM A106/A106M	Seamless	1.00
ASTM A333/A333M	Seamless	1.00
	Welded	1.00
ASTM A381	Double submerged arc welded	1.00
ASTM A671/A671M	Electric-fusion-welded	1.00
ASTM A672/A672M	Electric-fusion-welded	1.00
ASTM A691/A691M	Electric-fusion-welded	1.00
API Spec 5L	Seamless	1.00
	Electric resistance welded	1.00

Subpart C - Design Requirements (§§100-134)

	Electric flash welded	1.00
	Submerged arc welded	1.00
	Furnace lap welded	0.80
	Furnace butt welded	0.60

(2) The seam joint factor for pipe that is not covered by this paragraph must be approved by the Administrator.

[Amdt. 195-22, 46 FR 38360, July 27, 1981; 47 FR 32721, July 29, 1982, as amended by Amdt. 195-30, 49 FR 7569, Mar. 1, 1984; Amdt. 195-37, 51 FR 15335, Apr. 23, 1986; Amdt. 195-40, 54 FR 5628, Feb. 6, 1989; 58 FR 14524, Mar. 18, 1993; Amdt. 195-50, 59 FR 17281, Apr. 12, 1994; Amdt. 195-52, 59 FR 33396, 33397, June 28, 1994; Amdt. 195-63, 63 FR 37506, July 13, 1998; Amdt. 195-99, 80 FR 185, Jan. 5, 2015; Amdt. 195-107, 89 FR 33264, Apr. 29, 2024]

§195.108 External pressure.

Any external pressure that will be exerted on the pipe must be provided for in designing a pipeline system.

§195.110 External loads.

This section has been amended by Amdt. 195-107, eff. 6/28/24.

- (a) Anticipated external loads (e.g.), earthquakes, vibration, thermal expansion, and contraction must be provided for in designing a pipeline system. In providing for expansion and flexibility, §419 of ASME B31.4 must be followed.
- (b) The pipe and other components must be supported in such a way that the support does not cause excess localized stresses. In designing attachments to pipe, the added stress to the wall of the pipe must be computed and compensated for.

[34 FR 15473, Oct. 4, 1969 as amended by Amdt. 195-9, 41 FR 13590, Mar. 31, 1976; Amdt. 195-22, 46 FR 38357, July 27, 1981; Amdt. 195-48, 58 FR 14519, Mar. 18, 1993; Amdt. 195-107, 89 FR 33264, Apr. 29, 2024]

§195.111 Fracture propagation.

A carbon dioxide pipeline system must be designed to mitigate the effects of fracture propagation.

[Amdt. 195-45, 56 FR 26922, June 12, 1991]

§195.112 New pipe.

Any new pipe installed in a pipeline system must comply with the following:

- (a) The pipe must be made of steel of the carbon, low alloy-high strength, or alloy type that is able to withstand the internal pressures and external loads and pressures anticipated for the pipeline system.

- (b) The pipe must be made in accordance with a written pipe specification that sets forth the chemical requirements for the pipe steel and mechanical tests for the pipe to provide pipe suitable for the use intended.
- (c) Each length of pipe with a nominal outside diameter of 4½ in (114.3 mm) or more must be marked on the pipe or pipe coating with the specification to which it was made, the specified minimum yield strength or grade, and the pipe size. The marking must be applied in a manner that does not damage the pipe or pipe coating and must remain visible until the pipe is installed.

[Amdt. 195-22, 46 FR 38360, July 27, 1981, as amended by Amdt. 195-52, 59 FR 33396, June 28, 1994; Amdt. 195-63, 63 FR 37506, July 13, 1998]

§195.114 Used pipe.

Any used pipe installed in a pipeline system must comply with [§195.112](#) (a) and (b) and the following:

- (a) The pipe must be of a known specification and the seam joint factor must be determined in accordance with [§195.106](#)(e). If the specified minimum yield strength or the wall thickness is not known, it is determined in accordance with [§195.106](#) (b) or (c) as appropriate.
- (b) There may not be any:
 - (1) Buckles;
 - (2) Cracks, grooves, gouges, dents, or other surface defects that exceed the maximum depth of such a defect permitted by the specification to which the pipe was manufactured; or
 - (3) Corroded areas where the remaining wall thickness is less than the minimum thickness required by the tolerances in the specification to which the pipe was manufactured.

However, pipe that does not meet the requirements of paragraph (b)(3) of this section may be used if the operating pressure is reduced to be commensurate with the remaining wall thickness.

[Amdt. 195-22, 46 FR 38360, July 27, 1981; 47 FR 32721, July 29, 1982]

§195.116 Valves.

This section has been amended by Amdt. 195-107, eff. 6/28/24.

Each valve installed in a pipeline system must comply with the following:

- (a) The valve must be of a sound engineering design.
- (b) Materials subject to the internal pressure of the pipeline system, including welded and flanged ends, must be compatible with the pipe or fittings to which the valve is attached.
- (c) Each part of the valve that will be in contact with the carbon dioxide or hazardous liquid stream must be made of materials that are compatible with carbon dioxide or each hazardous liquid that it is anticipated will flow through the pipeline system.
- (d) Each valve must be both hydrostatically shell tested and hydrostatically seat tested without leakage to at least the requirements set forth in Section 11 of API Spec 6D (incorporated by reference, see [§ 195.3](#)).
- (e) Each valve other than a check valve must be equipped with a means for clearly indicating the position of the valve (open, closed, etc.).

- (f) Each valve must be marked on the body or the nameplate, with at least the following:
- (1) Manufacturer's name or trademark.
 - (2) Class designation or the maximum working pressure to which the valve may be subjected.
 - (3) Body material designation (the end connection material, if more than one type is used).
 - (4) Nominal valve size.

[34 FR 15473, Oct. 4, 1969 as amended by Amdt. 195-2, 35 FR 17183, Nov. 7, 1970; Amdt. 195-9, 41 FR 13590, Mar. 31, 1976; Amdt. 195-22, 46 FR 38357, July 27, 1981; Amdt. 195-45, 56 FR 26922, June 12, 1991; Amdt. 195-86, 71 FR 33402, June 9, 2006; Amdt. 195-94, 75 FR 48593, Aug. 11, 2010; Amdt. 195-99, 80 FR 168, Jan. 5, 2015; Amdt. 195-107, 89 FR 33264, Apr. 29, 2024]

§195.118 Fittings.

- (a) Butt-welding type fittings must meet the marking, end preparation, and the bursting strength requirements of ASME/ANSI B16.9 or MSS SP-75 (incorporated by reference, see § [195.3](#)).
- (b) There may not be any buckles, dents, cracks, gouges, or other defects in the fitting that might reduce the strength of the fitting.
- (c) The fitting must be suitable for the intended service and be at least as strong as the pipe and other fittings in the pipeline system to which it is attached.

[Amdt. 195-22, 46 FR 38360, July 27, 1981; 47 FR 32721, July 29, 1982, as amended at 58 FR 14524, Mar. 18, 1993; Amdt. 195-99, 80 FR 186, Jan. 5, 2015]

§195.120 Passage of internal inspection devices.

- (a) *General.* Except as provided in paragraphs (b) and (c) of this section, each new pipeline and each main line section of a pipeline where the line pipe, valve, fitting or other line component is replaced must be designed and constructed to accommodate the passage of instrumented internal inspection devices in accordance with NACE SP0102 (incorporated by reference, see § [195.3](#)).
- (b) *Exceptions.* This section does not apply to:
 - (1) Manifolds;
 - (2) Station piping such as at pump stations, meter stations, or pressure reducing stations;
 - (3) Piping associated with tank farms and other storage facilities;
 - (4) Cross-overs;
 - (5) Pipe for which an instrumented internal inspection device is not commercially available; and
 - (6) Offshore pipelines, other than lines 10 inches (254 millimeters) or greater in nominal diameter, that transport liquids to onshore facilities.
- (c) *Impracticability.* An operator may file a petition under § 190.9 for a finding that the requirements in paragraph (a) of this section should not be applied to a pipeline for reasons of impracticability.
- (d) *Emergencies.* An operator need not comply with paragraph (a) of this section in constructing a new or replacement segment of a pipeline in an emergency. Within 30 days after discovering the emergency, the operator must file a petition under § 190.9 for a finding that requiring the design and construction of the new or replacement pipeline segment to accommodate passage of instrumented internal inspection devices would be impracticable as a result of the emergency. If PHMSA denies the petition, within 1 year after the date of the notice of the denial, the operator

must modify the new or replacement pipeline segment to allow passage of instrumented internal inspection devices.

[Amdt. 195-102, 84 FR 52294, Oct. 1, 2019]

§195.122 Fabricated branch connections.

Each pipeline system must be designed so that the addition of any fabricated branch connections will not reduce the strength of the pipeline system.

§195.124 Closures.

Each closure to be installed in a pipeline system must comply with the 2007 ASME Boiler and Pressure Vessel Code (BPVC) (Section VIII, Division 1) (incorporated by reference, see [§195.3](#)), and must have pressure and temperature ratings at least equal to those of the pipe to which the closure is attached.

[Amdt. 195-99, 80 FR 186, Jan. 5, 2015]

§195.126 Flange connection.

Each component of a flange connection must be compatible with each other component and the connection as a unit must be suitable for the service in which it is to be used.

§195.128 Station piping.

Any pipe to be installed in a station that is subject to system pressure must meet the applicable requirements of this subpart.

§195.130 Fabricated assemblies.

Each fabricated assembly to be installed in a pipeline system must meet the applicable requirements of this subpart.

§195.132 Design and construction of aboveground breakout tanks.

- (a) Each aboveground breakout tank must be designed and constructed to withstand the internal pressure produced by the hazardous liquid to be stored therein and any anticipated external loads.
- (b) For aboveground breakout tanks first placed in service after October 2, 2000, compliance with paragraph (a) of this section requires one of the following:
 - (1) Shop-fabricated, vertical, cylindrical, closed top, welded steel tanks with nominal capacities of 90 to 750 barrels (14.3 to 119.2 m³) and with internal vapor space pressures that are approximately atmospheric must be designed and constructed in accordance with API Spec 12F (incorporated by reference, see [§195.3](#)).

- (2) Welded, low-pressure (i.e., internal vapor space pressure not greater than 15 psig (103.4 kPa)), carbon steel tanks that have wall shapes that can be generated by a single vertical axis of revolution must be designed and constructed in accordance with API Std 620 (incorporated by reference, see § [195.3](#)).
- (3) Vertical, cylindrical, welded steel tanks with internal pressures at the tank top approximating atmospheric pressures (i.e., internal vapor space pressures not greater than 2.5 psig (17.2 kPa), or not greater than the pressure developed by the weight of the tank roof) must be designed and constructed in accordance with API Std 650 (incorporated by reference, see § [195.3](#)).
- (4) High pressure steel tanks (i.e., internal gas or vapor space pressures greater than 15 psig (103.4 kPa)) with a nominal capacity of 2000 gallons (7571 liters) or more of liquefied petroleum gas (LPG) must be designed and constructed in accordance with API Std 2510 (incorporated by reference, see § [195.3](#)).

[Amdt. 195-66, 64 FR 15935, Apr. 2, 1999, as amended by Amdt. 195-99, 80 FR 186, Jan. 5, 2015; 80 FR 46848, Aug. 6, 2015]

§195.134 Leak detection.

- (a) *Scope.* This section applies to each hazardous liquid pipeline transporting liquid in single phase (without gas in the liquid).
- (b) *General.*
 - (1) For each pipeline constructed prior to October 1, 2019. Each pipeline must have a system for detecting leaks that complies with the requirements in § [195.444](#) by October 1, 2024.
 - (2) For each pipeline constructed on or after October 1, 2019. Each pipeline must have a system for detecting leaks that complies with the requirements in § [195.444](#) by October 1, 2020.
- (c) *CPM leak detection systems.* A new computational pipeline monitoring (CPM) leak detection system or replaced component of an existing CPM system must be designed in accordance with the requirements in section 4.2 of API RP 1130 (incorporated by reference, see § 195.3) and any other applicable design criteria in that standard.
- (d) *Exception.* The requirements of paragraph (b) of this section do not apply to offshore gathering or regulated rural gathering lines.

[Amdt. 195-102, 84 FR 52295, Oct. 1, 2019]

SubPart D - Construction (§§200-266)

SubPart D - Construction

- 195.200 [Scope.](#)
- 195.202 [Compliance with specifications or standards.](#)
- 195.204 [Inspection - General.](#)
- 195.205 [Repair, alteration and reconstruction of aboveground breakout tanks that have been in service](#)
- 195.206 [Material inspection.](#)
- 195.207 [Transportation of pipe.](#)
- 195.208 [Welding of supports and braces.](#)
- 195.210 [Pipeline location.](#)
- 195.212 [Bending of pipe.](#)
- 195.214 [Welding procedures](#)
- 195.216 [Welding: Miter joints.](#)
- 195.222 [Welders: Qualification of welders.](#)
- 195.224 [Welding: Weather.](#)
- 195.226 [Welding: Arc burns.](#)
- 195.228 [Welds and welding inspection: Standards of acceptability.](#)
- 195.230 [Welds: Repair or removal of defects.](#)
- 195.234 [Welds: Nondestructive testing.](#)
- 195.246 [Installation of pipe in a ditch.](#)
- 195.248 [Cover over buried pipeline.](#)
- 195.250 [Clearance between pipe and underground structures.](#)
- 195.252 [Backfilling.](#)
- 195.254 [Above ground components.](#)
- 195.256 [Crossing of railroads and highways.](#)
- 195.258 [Valves: General.](#)
- 195.260 [Valves: Location.](#)
- 195.262 [Pumping equipment.](#)
- 195.264 [Above ground breakout tanks.](#)
- 195.266 [Construction records.](#)

§195.200 Scope.

This subpart prescribes minimum requirements for constructing new pipeline systems with steel pipe, and for relocating, replacing, or otherwise changing existing pipeline systems that are constructed with steel pipe. However, this subpart does not apply to the movement of pipe covered by [§195.424](#).

§195.202 Compliance with specifications or standards.

Each pipeline system must be constructed in accordance with comprehensive written specifications or standards that are consistent with the requirements of this part.

§195.204 Inspection-general.

Inspection must be provided to ensure that the installation of pipe or pipeline systems is in accordance with the requirements of this subpart. Any operator personnel used to perform the inspection must be trained and qualified in the phase of construction to be inspected. An operator must not use operator personnel to perform a required inspection if the operator personnel performed the construction task requiring inspection. Nothing in this section prohibits the operator from inspecting construction tasks with operator personnel who are involved in other construction tasks.

[Amdt. 195-100, 80 FR 12780, Mar. 11, 2015]

§195.205 Repair, alteration and reconstruction of aboveground breakout tanks that have been in service.

- (a) Aboveground breakout tanks that have been repaired, altered, or reconstructed and returned to service must be capable of withstanding the internal pressure produced by the hazardous liquid to be stored therein and any anticipated external loads.
- (b) After October 2, 2000, compliance with paragraph (a) of this section requires the following:
 - (1) For tanks designed for approximate atmospheric pressure, constructed of carbon and low alloy steel, welded or riveted, and non- refrigerated; and for tanks built to API Std 650 (incorporated by reference, see §[195.3](#)) or its predecessor Standard 12C; repair, alteration; and reconstruction must be in accordance with API Std 653 (except section 6.4.3) (incorporated by reference, see §[195.3](#)).
 - (2) For tanks built to API Spec 12F (incorporated by reference, see §[195.3](#)) or API Std 620 (incorporated by reference, see §[195.3](#)), repair, alteration, and reconstruction must be in accordance with the design, welding, examination, and material requirements of those respective standards.
 - (3) For high-pressure tanks built to API Std 2510 (incorporated by reference, see §[195.3](#)), repairs, alterations, and reconstruction must be in accordance with API Std 510 (incorporated by reference, see §[195.3](#)).

[Amdt. 195-100, 80 FR 12780, Mar. 11, 2015]

§195.206 Material inspection.

No pipe or other component may be installed in a pipeline system unless it has been visually inspected at the site of installation to ensure that it is not damaged in a manner that could impair its strength or reduce its serviceability.

§195.207 Transportation of pipe.

- (a) *Railroad*. In a pipeline operated at a hoop stress of 20 percent or more of SMYS, an operator may not use pipe having an outer diameter to wall thickness ratio of 70 to 1, or more, that is transported by railroad unless the transportation is performed in accordance with API RP 5L1 (incorporated by reference, see §[195.3](#)).

- (b) *Ship or barge*. In a pipeline operated at a hoop stress of 20 percent or more of SMYS, an operator may not use pipe having an outer diameter to wall thickness ratio of 70 to 1, or more, that is transported by ship or barge on both inland and marine waterways, unless the transportation is performed in accordance with API RP 5LW (incorporated by reference, see § 195.3).
- (c) *Truck*. In a pipeline to be operated at a hoop stress of 20 percent or more of SMYS, an operator may not use pipe having an outer diameter to wall thickness ratio of 70 to 1, or more, that is transported by truck unless the transportation is performed in accordance with API RP 5LT (incorporated by reference, see § 195.3).

[Amdt. 195-94, 75 FR 48606, Aug. 11, 2010, as amended by Amdt. 195-99, 80 FR 186, Jan. 5, 2015]

§195.208 Welding of supports and braces.

Supports or braces may not be welded directly to pipe that will be operated at a pressure of more than 100 p.s.i. (689 kPa) gage.

[Amdt. 195-22, 46 FR 38360, July 27, 1981, as amended by Amdt. 195-63, 63 FR 37506, July 13, 1998]

§195.210 Pipeline location.

- (a) Pipeline right-of-way must be selected to avoid, as far as practicable, areas containing private dwellings, industrial buildings, and places of public assembly.
- (b) No pipeline may be located within 50 feet (15 meters) of any private dwelling, or any industrial building or place of public assembly in which persons work, congregate, or assemble, unless it is provided with at least 12 inches (305 millimeters) of cover in addition to that prescribed in [§195.248](#).

[Amdt. 195-22, 46 FR 39360, July 27, 1981, as amended by Amdt. 195-63, 63 FR 37506, July 13, 1998]

§195.212 Bending of pipe.

- (a) Pipe must not have a wrinkle bend.
- (b) Each field bend must comply with the following:
 - (1) A bend must not impair the serviceability of the pipe.
 - (2) Each bend must have a smooth contour and be free from buckling, cracks, or any other mechanical damage.
 - (3) On pipe containing a longitudinal weld, the longitudinal weld must be as near as practicable to the neutral axis of the bend unless-
 - (i) The bend is made with an internal bending mandrel; or
 - (ii) The pipe is 12¾ in (324 mm) or less nominal outside diameter or has a diameter to wall thickness ratio less than 70.
- (c) Each circumferential weld which is located where the stress during bending causes a permanent deformation in the pipe must be nondestructively tested either before or after the bending process.

[Amdt. 195-22, 46 FR 38360, July 27, 1981, as amended by Amdt. 195-52, 59 FR 33396, June 28, 1994; Amdt. 195-63, 63 FR 37506, July 13, 1998]

§195.214 Welding procedures.

This section has been amended by Amdt. 195-107, eff. 6/28/24.

- (a) Welding must be performed by a qualified welder or welding operator in accordance with welding procedures qualified under section 5 (except for Note 2 in section 5.4.2.2), section 12, Appendix A or Appendix B of API Std 1104 (incorporated by reference, see § [195.3](#)), or Section IX of the ASME Boiler and Pressure Vessel Code (ASME BPVC) (incorporated by reference, see § [195.3](#)). The quality of the test welds used to qualify the welding procedures must be determined by destructive testing.
- (b) Each welding procedure must be recorded in detail, including the results of the qualifying tests. This record must be retained and followed whenever the procedure is used.

[Amdt. 195-38, 51 FR 20297, June 4, 1986, as amended at Amdt. 195-81, 69 FR 32897, June 14, 2004; Amdt. 195-99, 80 FR 186, Jan. 5, 2015; Amdt. 195-100, 80 FR 12780, Mar. 11, 2015; Amdt. 195-101, 82 FR 7999, Jan. 23, 2017; Amdt. 195-107, 89 FR 33264, Apr. 29, 2024]

§195.216 Welding: Miter joints.

A miter joint is not permitted (not including deflections up to 3° that are caused by misalignment).

§195.218 [Removed]

[34 FR 15473, Oct. 4, 1969 as amended by Amdt. 195-19, 45 FR 59161, September 8, 1980]

§195.220 [Removed]

[34 FR 15473, Oct. 4, 1969 as amended by Amdt. 195-22, 46 FR 38357, July 27, 1981; Amdt. 195-25, 47 FR 55396, Dec. 9, 1982]

§195.222 Welders and welding operators: Qualification of welders and welding operators.

- (a) Each welder or welding operator must be qualified in accordance with section 6, section 12, Appendix A or Appendix B of API Std 1104 (incorporated by reference, see § [195.3](#)), or section IX of the ASME Boiler and Pressure Vessel Code (ASME BPVC), (incorporated by reference, see § [195.3](#)) except that a welder or welding operator qualified under an earlier edition than listed in § [195.3](#), may weld but may not requalify under that earlier edition.
- (b) No welder or welding operator may weld with a welding process unless, within the preceding 6 calendar months, the welder or welding operator has--
 - (1) Engaged in welding with that process; and
 - (2) Had one weld tested and found acceptable under section 9 or Appendix A of API Std 1104 (incorporated by reference, see § [195.3](#)).

[Amdt. 195-81, 69 FR 54593, Sept. 9, 2004, as amended by Amdt. 195-86, 71 FR 33409, June 9, 2006; Amdt. 195-99, 80 FR 186, Jan. 5, 2015; Amdt. 195-100, 80 FR 12780, Mar. 11, 2015; Amdt. 195-101, 82 FR 7999, Jan. 23, 2017]

§195.224 Welding: Weather.

Welding must be protected from weather conditions that would impair the quality of the completed weld.

§195.226 Welding: Arc burns.

- (a) Each arc burn must be repaired.
- (b) An arc burn may be repaired by completely removing the notch by grinding, if the grinding does not reduce the remaining wall thickness to less than the minimum thickness required by the tolerances in the specification to which the pipe is manufactured. If a notch is not repairable by grinding, a cylinder of the pipe containing the entire notch must be removed.
- (c) A ground may not be welded to the pipe or fitting that is being welded.

§195.228 Welds and welding inspection: Standards of acceptability.

- (a) Each weld and welding must be inspected to insure compliance with the requirements of this subpart. Visual inspection must be supplemented by nondestructive testing.
- (b) The acceptability of a weld is determined according to the standards in section 9 or Appendix A of API Std 1104 (incorporated by reference, see [§195.3](#)). Appendix A of API Std 1104 may not be used to accept cracks.

[Amdt. 195-22, 46 FR 38360, July 27, 1981, as amended by Amdt. 195-52, 59 FR 33397, June 28, 1994; Amdt. 195-81, 69 FR 32898, June 14, 2004; Amdt. 195-99, 80 FR 186, Jan. 5, 2015; Amdt. 195-100, 80 FR 12780, Mar. 11, 2015]

§195.230 Welds: Repair or removal of defects.

- (a) Each weld that is unacceptable under [§195.228](#) must be removed or repaired. Except for welds on an offshore pipeline being installed from a pipelay vessel, a weld must be removed if it has a crack that is more than 8 percent of the weld length.
- (b) Each weld that is repaired must have the defect removed down to sound metal and the segment to be repaired must be preheated if conditions exist which would adversely affect the quality of the weld repair. After repair, the segment of the weld that was repaired must be inspected to ensure its acceptability.
- (c) Repair of a crack, or of any defect in a previously repaired area must be in accordance with written weld repair procedures that have been qualified under [§195.214](#). Repair procedures must provide that the minimum mechanical properties specified for the welding procedure used to make the original weld are met upon completion of the final weld repair.

[Amdt. 195-29, 48 FR 48674, Oct. 20, 1983]

§195.232 [Removed]

[Removed]

§195.234 Welds: Nondestructive testing.

- (a) A weld may be nondestructively tested by any process that will clearly indicate any defects that may affect the integrity of the weld.
- (b) Any nondestructive testing of welds must be performed-
 - (1) In accordance with a written set of procedures for nondestructive testing; and
 - (2) With personnel that have been trained in the established procedures and in the use of the equipment employed in the testing.
- (c) Procedures for the proper interpretation of each weld inspection must be established to ensure the acceptability of the weld under [§195.228](#).
- (d) During construction, at least 10 percent of the girth welds made by each welder and welding operator during each welding day must be nondestructively tested over the entire circumference of the weld.
- (e) All girth welds installed each day in the following locations must be nondestructively tested over their entire circumference, except that when nondestructive testing is impracticable for a girth weld, it need not be tested if the number of girth welds for which testing is impracticable does not exceed 10 percent of the girth welds installed that day:
 - (1) At any onshore location where a loss of hazardous liquid could reasonably be expected to pollute any stream, river, lake, reservoir, or other body of water, and any offshore area;
 - (2) Within railroad or public road rights-of-way;
 - (3) At overhead road crossings and within tunnels;
 - (4) Within the limits of any incorporated subdivision of a State government; and
 - (5) Within populated areas, including, but not limited to, residential subdivisions, shopping centers, schools, designated commercial areas, industrial facilities, public institutions, and places of public assembly.
- (f) When installing used pipe, 100 percent of the old girth welds must be nondestructively tested.
- (g) At pipeline tie-ins, including tie-ins of replacement sections, 100 percent of the girth welds must be nondestructively tested.

[Amdt. 195-22, 46 FR 38360, July 27, 1981, as amended by Amdt. 195-35, 50 FR 37192, Sept. 21, 1985; Amdt. 195-52, 59 FR 33397, June 28, 1994; Amdt. 195-100, 80 FR 12780, Mar. 11, 2015]

§195.236 [Removed]

[34 FR 15473, Oct. 4, 1969 as amended by Amdt. 195-22, 46 FR 38357, July 27, 1981; Amdt 195-73, 66 FR 66993, December 27, 2001]

§195.238 [Removed]

[34 FR 15473, Oct. 4, 1969 as amended by Amdt. 195-11, 41 FR 34035, August 12, 1976; Amdt. 195-22, 46 FR 38357, July 27, 1981; Amdt 195-73, 66 FR 66993, December 27, 2001]

§195.242 [Removed]

[34 FR 15473, Oct. 4, 1969 as amended by Amdt. 195-11, 41 FR 34035, August 12, 1976; Amdt. 195-22, 46 FR 38357, July 27, 1981; Amdt. 195-66, 64 FR 15926, April 2, 1999; Amdt 195-73, 66 FR 66993, December 27, 2001]

§195.244 [Removed]

[34 FR 15473, Oct. 4, 1969 as amended by Amdt. 195-22, 46 FR 38357, July 27, 1981; Amdt 195-73, 66 FR 66993, December 27, 2001]

§195.246 Installation of pipe in a ditch.

- (a) All pipe installed in a ditch must be installed in a manner that minimizes the introduction of secondary stresses and the possibility of damage to the pipe.
- (b) Except for pipe in the Gulf of Mexico and its inlets in waters less than 15 feet deep, all offshore pipe in water at least 12 feet deep (3.7 meters) but not more than 200 feet deep (61 meters) deep as measured from the mean low water must be installed so that the top of the pipe is below the underwater natural bottom (as determined by recognized and generally accepted practices) unless the pipe is supported by stanchions held in place by anchors or heavy concrete coating or protected by an equivalent means.

[Amdt. 195-22, 46 FR 38360, July 27, 1981, as amended by Amdt. 195-52, 59 FR 33397, June 28, 1994; 59 FR 36256, July 15, 1994; Amdt. 195-85, 69 FR 48407, Aug. 10, 2004]

§195.248 Cover over buried pipeline.

- (a) Unless specifically exempted in this subpart, all pipe must be buried so that it is below the level of cultivation. Except as provided in paragraph (b) of this section, the pipe must be installed so that the cover between the top of the pipe and the ground level, road bed, river bottom, or underwater natural bottom (as determined by recognized and generally accepted practices), as applicable, complies with the following table:

Location	Cover inches(millimeters)	
	For normal excavation	For rock excavation ¹
Industrial, commercial, and residential areas	36 (914)	30 (762)
Crossing of inland bodies of water with a width of at least 100 feet (30.5 meters) from high water mark to high water mark	48 (1219)	18 (457)
Drainage ditches at public roads and railroads	36 (914)	36 (914)

Deepwater port safety zones	48 (1219)	24 (610)
Gulf of Mexico and its inlets in waters less than 15 feet (4.6 meters) deep as measured from mean low water	36 (914)	18 (457)
Other offshore areas under water less than 12 ft (3.7 meters) deep as measured from mean low water	36 (914)	18 (457)
Any other area	30 (762)	18 (457)

¹ Rock excavation is any excavation that requires blasting or removal by equivalent means.

(b) Except for the Gulf of Mexico and its inlets in waters less than 15 feet (4.6 meters) deep, less cover than the minimum required by paragraph (a) of this section and § [195.210](#) may be used if-

- (1) It is impracticable to comply with the minimum cover requirements; and
- (2) Additional protection is provided that is equivalent to the minimum required cover.

[Amdt. 195-22, 46 FR 38360, July 27, 1981; 47 FR 32721, July 29, 1982, as amended by Amdt. 195-52, 59 FR 33397, June 28, 1994; 59 FR 36256, July 15, 1994; Amdt. 195-63, 63 FR 37506, July 13, 1998; Amdt. 195-95, 69 FR 48407, Aug. 10, 2004; Amdt. 195-101, 82 FR 7999, Jan. 23, 2017]

§195.250 Clearance between pipe and underground structures.

Any pipe installed underground must have at least 12 inches (305 millimeters) of clearance between the outside of the pipe and the extremity of any other underground structure, except that for drainage tile the minimum clearance may be less than 12 inches (305 millimeters) but not less than 2 inches (51 millimeters). However, where 12 inches (305 millimeters) of clearance is impracticable, the clearance may be reduced if adequate provisions are made for corrosion control.

[Amdt. 195-22, 46 FR 38360, July 27, 1981, as amended by Amdt. 195-63, 63 FR 37506, July 13, 1998]

§195.252 Backfilling.

When a ditch for a pipeline is backfilled, it must be backfilled in a manner that:

- (a) Provides firm support under the pipe; and
- (b) Prevents damage to the pipe and pipe coating from equipment or from the backfill material.

[Amdt. 195-78, 68 FR 53528, Sept. 11, 2003]

§195.254 Above ground components.

- (a) Any component may be installed above ground in the following situations, if the other applicable requirements of this part are complied with:
 - (1) Overhead crossings of highways, railroads, or a body of water.
 - (2) Spans over ditches and gullies.
 - (3) Scraper traps or block valves.
 - (4) Areas under the direct control of the operator.

- (5) In any area inaccessible to the public.
- (b) Each component covered by this section must be protected from the forces exerted by the anticipated loads.

§195.256 Crossing of railroads and highways.

The pipe at each railroad or highway crossing must be installed so as to adequately withstand the dynamic forces exerted by anticipated traffic loads.

§195.258 Valves: General.

- (a) Each valve must be installed in a location that is accessible to authorized employees and that is protected from damage or tampering.
- (b) Each submerged valve located offshore or in inland navigable waters must be marked, or located by conventional survey techniques, to facilitate quick location when operation of the valve is required.
- (c) For all onshore hazardous liquid or carbon dioxide pipeline segments with diameters greater than or equal to 6 inches that are constructed after April 10, 2023, the operator must install rupture-mitigation valves (RMV) or an alternative equivalent technology whenever a valve must be installed to meet the appropriate valve spacing requirements of this section and § [195.260](#). An operator using alternative equivalent technology must notify PHMSA in accordance with the procedure in paragraph (e) of this section. All RMVs and alternative equivalent technology installed as required by this section must meet the requirements of § [195.419](#). An operator may request an extension of the installation compliance deadline requirements of this paragraph if it can demonstrate to PHMSA, in accordance with the notification procedures in § [195.18](#), that those installation deadline requirements would be economically, technically, or operationally infeasible for a particular new pipeline.
- (d) For all entirely replaced onshore hazardous liquid or carbon dioxide pipeline segments with diameters greater than or equal to 6 inches that have been replaced after April 10, 2023, the operator must install RMVs or an alternative equivalent technology whenever a valve must be installed to meet the appropriate valve spacing requirements of this section. An operator using alternative equivalent technology must notify PHMSA in accordance with the procedure in paragraph (e) of this section. All valves installed as required by this section must meet the requirements of § [195.419](#). The requirements of this paragraph (d) apply when the applicable pipeline replacement project involves a valve, either through addition, replacement, or removal. An operator may request an extension of the installation compliance deadline requirements of this paragraph if it can demonstrate to PHMSA, in accordance with the notification procedures in § [195.18](#), that those installation deadline requirements would be economically, technically, or operationally infeasible for a particular pipeline replacement project.
- (e) If an operator elects to use alternative equivalent technology in accordance with paragraph (c) or (d) of this section, the operator must notify PHMSA in accordance with § [195.18](#). The operator must include a technical and safety evaluation in its notice to PHMSA. Valves that are installed as alternative equivalent technology must comply with §§ [195.418](#), [195.419](#), and [195.420](#). An operator requesting use of manual valves as an alternative equivalent technology must also include within the notification submitted to PHMSA a demonstration that installation of an RMV as otherwise required would be economically, technically, or operationally infeasible. An operator may use a

manual pump station valve at a continuously manned station as an alternative equivalent technology. Such a valve used as an alternative equivalent technology would not require a notification to PHMSA in accordance with § 195.18, but it must comply with §§ 195.419 and 195.420.

(f) The requirements of paragraphs (c) through (e) of this section do not apply to gathering lines.

[Amdt. 195-105, 87 FR 20940, Apr. 8, 2022; Amdt. 195-106, 88 FR 50056, Aug. 1, 2023]

§195.260 Valves: Location.

A valve must be installed at each of the following locations:

- (a) On the suction end and the discharge end of a pump station in a manner that permits isolation of the pump station equipment in the event of an emergency.
- (b) On each pipeline entering or leaving a breakout storage tank area in a manner that permits isolation of the tank from other facilities.
- (c) On each pipeline at locations along the pipeline system that will minimize or prevent safety risks, property damage, or environmental harm from accidental hazardous liquid or carbon dioxide discharges, as appropriate for onshore areas, offshore areas, and high-consequence areas (HCA). For newly constructed or entirely replaced onshore hazardous liquid or carbon dioxide pipeline segments, as that term is defined at § [195.2](#), that are installed after April 10, 2023, valve spacing must not exceed 15 miles for pipeline segments that could affect or are in HCAs, as defined in § [195.450](#), and 20 miles for pipeline segments that could not affect HCAs. Valves on pipeline segments that are located in HCAs or which could affect HCAs must be installed at locations as determined by the operator's process for identifying preventive and mitigative measures established pursuant to § [195.452](#)(i) and by using the selection process in section I.B of [appendix C](#) of part 195, but with a maximum distance that does not exceed 7 1/2 miles from the endpoints of the HCA segment or the segment that could affect an HCA. An operator may request an exemption from the compliance deadline requirements of this section for valve installation at the specified valve spacing if it can demonstrate to PHMSA, in accordance with the notification procedures in § [195.18](#), that those compliance deadline requirements would be economically, technically, or operationally infeasible.
- (d) On each lateral takeoff from a pipeline in a manner that permits shutting off the lateral without interrupting flow in the pipeline.
- (e) On each side of one or more adjacent water crossings that are more than 100 feet (30 meters) wide from high water mark to high water mark, as follows:
 - (1) Valves must be installed at locations outside of the 100-year flood plain or be equipped with actuators or other control equipment that is installed so as not to be impacted by flood conditions; and
 - (2) The maximum spacing interval between valves that protect multiple adjacent water crossings cannot exceed 1 mile in length.
- (f) On each side of a reservoir holding water for human consumption.
- (g) On each highly volatile liquid (HVL) pipeline that is located in a high-population area or other populated area, as defined in § [195.450](#), and that is constructed, or where 2 or more miles of pipe have been replaced within any 5 contiguous miles within any 24-month period, after April 10, 2023,

with a maximum valve spacing of 7 1/2 miles. The maximum valve spacing intervals may be increased by 1.25 times the distance up to a 9 3/8-mile spacing, provided the operator:

- (1) Submits for PHMSA review a notification pursuant to § [195.18](#) requesting alternative spacing because installation of a valve at a particular location between a 7-mile to a 7 1/2-mile spacing would be economically, technically, or operationally infeasible, and that an alternative spacing would not adversely impact safety; and
 - (2) Keeps the records necessary to support that determination for the useful life of the pipeline.
- (h) An operator may submit for PHMSA review, in accordance with § [195.18](#), a notification requesting site-specific exemption from the valve installation requirements or valve spacing requirements of paragraph (c), (e), or (f) of this section and demonstrating such exemption would not adversely affect safety. An operator may also submit for PHMSA review, in accordance with § 195.18, a notification requesting an extension of the compliance deadline requirements for valve installation and spacing of this section because those compliance deadline requirements would be economically, technically, or operationally infeasible for a particular new construction or pipeline replacement project.
- (i) An operator of a gathering line must only comply with the requirements of § 195.260 effective as of October 4, 2022, and need not comply with the other requirements of this section.

[Amdt. 195-22, 46 FR 38360, July 27, 1981; 47 FR 32721, July 29, 1982; Amdt. 195-50, 59 FR 17281, Apr. 12, 1994; Amdt. 195-63, 63 FR 37506, July 13, 1998; Amdt 195-105, 87 FR 20940, Apr. 8, 2022; Amdt. 195-106, 88 FR 50056, Aug. 1, 2023]

§195.262 Pumping equipment.

- (a) Adequate ventilation must be provided in pump station buildings to prevent the accumulation of hazardous vapors. Warning devices must be installed to warn of the presence of hazardous vapors in the pumping station building.
- (b) The following must be provided in each pump station:
 - (1) Safety devices that prevent overpressuring of pumping equipment, including the auxiliary pumping equipment within the pumping station.
 - (2) A device for the emergency shutdown of each pumping station.
 - (3) If power is necessary to actuate the safety devices, an auxiliary power supply.
- (c) Each safety device must be tested under conditions approximating actual operations and found to function properly before the pumping station may be used.
- (d) Except for offshore pipelines, pumping equipment must be installed on property that is under the control of the operator and at least 15.2 m (50 ft) from the boundary of the pump station.
- (e) Adequate fire protection must be installed at each pump station. If the fire protection system installed requires the use of pumps, motive power must be provided for those pumps that is separate from the power that operates the station.

[Amdt. 195-22, 46 FR 38360, July 27, 1981, as amended by Amdt. 195-52, 59 FR 33397, June 28, 1994]

§195.254 Above ground components.

- (a) Any component may be installed above ground in the following situations, if the other applicable requirements of this part are complied with:
 - (1) Overhead crossings of highways, railroads, or a body of water.
 - (2) Spans over ditches and gullies.
 - (3) Scraper traps or block valves.
 - (4) Areas under the direct control of the operator.
 - (5) In any area inaccessible to the public.
- (b) Each component covered by this section must be protected from the forces exerted by the anticipated loads.

§195.264 Impoundment, protection against entry, normal/emergency venting or pressure/vacuum relief for aboveground breakout tanks.

- (a) A means must be provided for containing hazardous liquids in the event of spillage or failure of an aboveground breakout tank.
- (b) After October 2, 2000, compliance with paragraph (a) of this section requires the following for the aboveground breakout tanks specified:
 - (1) For tanks built to API Spec 12F, API Std 620, and others (such as API Std 650 (or its predecessor Standard 12C)), the installation of impoundment must be in accordance with the following sections of NFPA- 30 (incorporated by reference, see [§195.3](#)):
 - (i) Impoundment around a breakout tank must be installed in accordance with section 22.11.2; and
 - (ii) Impoundment by drainage to a remote impounding area must be installed in accordance with section 22.11.1.
 - (2) For tanks built to API Std 2510 (incorporated by reference, see [§195.3](#)), the installation of impoundment must be in accordance with section 5 or 11 of API Std 2510.
- (c) Aboveground breakout tank areas must be adequately protected against unauthorized entry.
- (d) Normal/emergency relief venting must be provided for each atmospheric pressure breakout tank. Pressure/vacuum-relieving devices must be provided for each low-pressure and high-pressure breakout tank.
- (e) For normal/emergency relief venting and pressure/vacuum-relieving devices installed on aboveground breakout tanks after October 2, 2000, compliance with paragraph (d) of this section requires the following for the tanks specified:
 - (1) Normal/emergency relief venting installed on atmospheric pressure tanks built to API Spec 12F must be in accordance with section 4 and Appendices B and C of API Spec 12F (incorporated by reference, see [§195.3](#)).
 - (2) Normal/emergency relief venting installed on atmospheric pressure tanks (such as those built to API Std 650 or its predecessor Standard 12C) must be in accordance with API Std 2000 (incorporated by reference, see [§195.3](#)).
 - (3) Pressure-relieving and emergency vacuum-relieving devices installed on low-pressure tanks built to API Std 620 must be in accordance with Section 9 of API Std 620 (incorporated by reference,

see §195.3) and its references to the normal and emergency venting requirements in API Std 2000 (incorporated by reference, see § [195.3](#)).

- (4) Pressure and vacuum-relieving devices installed on high- pressure tanks built to API Std 2510 must be in accordance with sections 7 or 11 of API Std 2510 (incorporated by reference, see § [195.3](#)).

[Amdt. 195-66, 64 FR 15935, Apr. 2, 1999, as amended by Amdt. 195-86, 71 FR 33410, June 9, 2006; Amd. 195-94, 75 FR 48606, Aug. 11, 2010; Amdt. 195-99, 80 FR 186, Jan. 5, 2015; 80 FR 46848, Aug. 6, 2015]

§195.266 Construction records.

A complete record that shows the following must be maintained by the operator involved for the life of each pipeline facility:

- (a) The total number of girth welds and the number nondestructively tested, including the number rejected and the disposition of each rejected weld.
- (b) The amount, location; and cover of each size of pipe installed.
- (c) The location of each crossing of another pipeline.
- (d) The location of each buried utility crossing.
- (e) The location of each overhead crossing.
- (f) The location of each valve and corrosion test station.

[Amdt. 195-22, 46 FR 38360, July 27, 1981, as amended by Amdt. 195-34, 50 FR 34474, Aug. 26, 1985]

SubPart E - Pressure Testing (§§300-310)

SubPart E - Pressure Testing

- 195.300 [Scope.](#)
- 195.302 [General requirements.](#)
- 195.303 [Risk-based alternative to pressure testing older hazardous liquid and carbon dioxide pipelines.](#)
- 195.304 [Test pressure.](#)
- 195.305 [Testing of components.](#)
- 195.306 [Test medium.](#)
- 195.307 [Pressure testing aboveground breakout tanks](#)
- 195.308 [Testing of tie-ins.](#)
- 195.310 [Records.](#)

§195.300 Scope.

This subpart prescribes minimum requirements for the pressure testing of steel pipelines. However, this subpart does not apply to the movement of pipe under [§195.424](#).

[Amdt. 195-51, 59 FR 29384, June 7, 1994]

§195.302 General requirements.

- (a) Except as otherwise provided in this section and in [§195.305\(b\)](#) , no operator may operate a pipeline unless it has been pressure tested under this subpart without leakage. In addition, no operator may return to service a segment of pipeline that has been replaced, relocated, or otherwise changed until it has been pressure tested under this subpart without leakage.
- (b) Except for pipelines converted under [§195.5](#), the following pipelines may be operated without pressure testing under this subpart:
 - (1) Any hazardous liquid pipeline whose maximum operating pressure is established under [§195.406\(a\)\(5\)](#) that is-
 - (i) An interstate pipeline constructed before January 8, 1971;
 - (ii) An interstate offshore gathering line constructed before August 1, 1977;
 - (iii) An intrastate pipeline constructed before October 21, 1985; or
 - (iv) A low-stress pipeline constructed before August 11, 1994 that transports HVL.
 - (2) Any carbon dioxide pipeline constructed before July 12, 1991, that-
 - (i) Has its maximum operating pressure established under [§195.406\(a\)\(5\)](#); or
 - (ii) Is located in a rural area as part of a production field distribution system.
 - (3) Any low-stress pipeline constructed before August 11, 1994 that does not transport HVL.
 - (4) Those portions of older hazardous liquid and carbon dioxide pipelines for which an operator has elected the risk-based alternative under [Sec. 195.303](#) and which are not required to be tested based on the risk-based criteria.

(c) Except for pipelines that transport HVL onshore, low-stress pipelines, and pipelines covered under Sec. [195.303](#), the following compliance deadlines apply to pipelines under paragraphs (b)(1) and (b)(2)(i) of this section that have not been pressure tested under this subpart:

- (1) Before December 7, 1998, for each pipeline each operator shall-
 - (i) Plan and schedule testing according to this paragraph; or
 - (ii) Establish the pipeline's maximum operating pressure under [§195.406\(a\)\(5\)](#).
- (2) For pipelines scheduled for testing, each operator shall-
 - (i) Before December 7, 2000, pressure test-
 - (A) Each pipeline identified by name, symbol, or otherwise that existing records show contains more than 50 percent by mileage (length) of electric resistance welded pipe manufactured before 1970; and
 - (B) At least 50 percent of the mileage (length) of all other pipelines; and
 - (ii) Before December 7, 2003, pressure test the remainder of the pipeline mileage (length).

[Amdt. 195-51, 59 FR 29384, June 7, 1994, as amended by Amdt. 195-53, 59 FR 35471, July 12, 1994; Amdt. 195-51B, 61 FR 43027, Aug. 20, 1996; Amdt. 195-58, 62 FR 54592, Oct. 21, 1997; Amdt. 195-63, 63 FR 37506, July 13, 1998; Amdt. 195-65, 63 FR 59479, Nov. 4, 1998]

§195.303 Risk-based alternative to pressure testing older hazardous liquid and carbon dioxide pipelines.

- (a) An operator may elect to follow a program for testing a pipeline on risk-based criteria as an alternative to the pressure testing in [§ 195.302\(b\)\(1\)\(i\)-\(iii\)](#) and [§ 195.302\(b\)\(2\)\(i\)](#) of this subpart. [Appendix B](#) provides guidance on how this program will work. An operator electing such a program shall assign a risk classification to each pipeline segment according to the indicators described in paragraph (b) of this section as follows:
 - (1) Risk Classification A if the location indicator is ranked as low or medium risk, the product and volume indicators are ranked as low risk, and the probability of failure indicator is ranked as low risk;
 - (2) Risk Classification C if the location indicator is ranked as high risk; or
 - (3) Risk Classification B.
- (b) An operator shall evaluate each pipeline segment in the program according to the following indicators of risk:
 - (1) The location indicator is-
 - (i) High risk if an area is non-rural or environmentally sensitive¹; or
 - (ii) Medium risk; or
 - (iii) Low risk if an area is not high or medium risk.
 - (2) The product indicator is (See [Appendix B](#), Table C).
 - (i) High risk if the product transported is highly toxic or is both highly volatile and flammable;
 - (ii) Medium risk if the product transported is flammable with a flashpoint of less than 100 deg. F, but not highly volatile; or
 - (iii) Low risk if the product transported is not high or medium risk.

- (3) The volume indicator is-
 - (i) High risk if the line is at least 18 inches in nominal diameter;
 - (ii) Medium risk if the line is at least 10 inches, but less than 18 inches, in nominal diameter; or
 - (iii) Low risk if the line is not high or medium risk.
- (4) The probability of failure indicator is-
 - (i) High risk if the segment has experienced more than three failures in the last 10 years due to time-dependent defects (e.g., corrosion, gouges, or problems developed during manufacture, construction or operation, etc.); or
 - (ii) Low risk if the segment has experienced three failures or less in the last 10 years due to time-dependent defects.
- (c) The program under paragraph (a) of this section shall provide for pressure testing for a segment constructed of electric resistance-welded (ERW) pipe and lapwelded pipe manufactured prior to 1970 susceptible to longitudinal seam failures as determined through paragraph (d) of this section. The timing of such pressure test may be determined based on risk classifications discussed under paragraph (b) of this section. For other segments, the program may provide for use of a magnetic flux leakage or ultrasonic internal inspection survey as an alternative to pressure testing and, in the case of such segments in Risk Classification A, may provide for no additional measures under this subpart.
- (d) All pre-1970 ERW pipe and lapwelded pipe is deemed susceptible to longitudinal seam failures unless an engineering analysis shows otherwise. In conducting an engineering analysis an operator must consider the seam-related leak history of the pipe and pipe manufacturing information as available, which may include the pipe steel's mechanical properties, including fracture toughness; the manufacturing process and controls related to seam properties, including whether the ERW process was high-frequency or low-frequency, whether the weld seam was heat treated, whether the seam was inspected, the test pressure and duration during mill hydrotest; the quality control of the steel-making process; and other factors pertinent to seam properties and quality.
- (e) Pressure testing done under this section must be conducted in accordance with this subpart. Except for segments in Risk Classification B which are not constructed with pre-1970 ERW pipe, water must be the test medium.
- (f) An operator electing to follow a program under paragraph (a) must develop plans that include the method of testing and a schedule for the testing by December 7, 1998. The compliance deadlines for completion of testing are as shown in the table below:

§ 195.303--Test Deadlines		
Pipeline segment	Risk Classification	Test deadline
Pre-1970 Pipe susceptible to longitudinal seam failures [defined in § 195.303(c) & (d)].	C or B	12/7/2000.
	A	12/7/2002.
All Other Pipeline Segments	C	12/7/2002.
	B	12/7/2004.
	A	Additional testing not required.

- (g) An operator must review the risk classifications for those pipeline segments which have not yet been tested under paragraph (a) of this section or otherwise inspected under paragraph (c) of this section

at intervals not to exceed 15 months. If the risk classification of an untested or uninspected segment changes, an operator must take appropriate action within two years, or establish the maximum operating pressure under [§ 195.406\(a\)\(5\)](#).

- (h) An operator must maintain records establishing compliance with this section, including records verifying the risk classifications, the plans and schedule for testing, the conduct of the testing, and the review of the risk classifications.
- (i) An operator may discontinue a program under this section only after written notification to the Administrator and approval, if needed, of a schedule for pressure testing.

[Amdt. 195-65, 63 FR 59480, Nov. 4, 1998]

§195.304 Test pressure.

The test pressure for each pressure test conducted under this subpart must be maintained throughout the part of the system being tested for at least 4 continuous hours at a pressure equal to 125 percent, or more, of the maximum operating pressure and, in the case of a pipeline that is not visually inspected for leakage during the test, for at least an additional 4 continuous hours at a pressure equal to 110 percent, or more, of the maximum operating pressure.

[Amdt. 195-51, 59 FR 29384, June 7, 1994. Redesignated by Amdt. 195-65, 63 FR 59480, Nov. 4, 1998]

§195.305 Testing of components.

- (a) Each pressure test under [§195.302](#) must test all pipe and attached fittings, including components, unless otherwise permitted by paragraph (b) of this section.
- (b) A component, other than pipe, that is the only item being replaced or added to the pipeline system need not be hydrostatically tested under paragraph (a) of this section if the manufacturer certifies that either-
 - (1) The component was hydrostatically tested at the factory; or
 - (2) The component was manufactured under a quality control system that ensures each component is at least equal in strength to a prototype that was hydrostatically tested at the factory.

[Amdt. 195-22, 46 FR 38360, July 27, 1981, as amended by Amdt. 195-51, 59 FR 29385, June 7, 1994; Amdt. 195-52, 59 FR 33397, June 28, 1994. Redesignated by Amdt. 195-65, 63 FR 59480, Nov. 4, 1998]

§195.306 Test medium.

- (a) Except as provided in paragraphs (b), (c), and (d) of this section, water must be used as the test medium.
- (b) Except for offshore pipelines, liquid petroleum that does not vaporize rapidly may be used as the test medium if-
 - (1) The entire pipeline section under test is outside of cities and other populated areas;
 - (2) Each building within 300 feet (91 meters) of the test section is unoccupied while the test pressure is equal to or greater than a pressure which produces a hoop stress of 50 percent of specified minimum yield strength;

- (3) The test section is kept under surveillance by regular patrols during the test; and
 - (4) Continuous communication is maintained along entire test section.
- (c) Carbon dioxide pipelines may use inert gas or carbon dioxide as the test medium if-
- (1) The entire pipeline section under test is outside of cities and other populated areas;
 - (2) Each building within 300 feet (91 meters) of the test section is unoccupied while the test pressure is equal to or greater than a pressure that produces a hoop stress of 50 percent of specified minimum yield strength;
 - (3) The maximum hoop stress during the test does not exceed 80 percent of specified minimum yield strength;
 - (4) Continuous communication is maintained along entire test section; and
 - (5) The pipe involved is new pipe having a longitudinal joint factor of 1.00.
- (d) Air or inert gas may be used as the test medium in low-stress pipelines.

[Amdt. 195-22, 46 FR 38360, July 27, 1991, as amended by Amdt. 195-45, 56 FR 26926, June 12, 1991; Amdt. 195-51, 59 FR 29385, June 7, 1994; Amdt. 195-53, 59 FR 35471, July 12, 1994; Amdt. 195-51A, 59 FR 41260, Aug. 11, 1994; Amdt. 195-63, 63 FR 37506, July 13, 1998]

§195.307 Pressure testing aboveground breakout tanks.

This section has been amended by Amdt. 195-107, eff. 6/28/24.

- (a) For aboveground breakout tanks built to API Spec 12F (incorporated by reference, see §[195.3](#)) and first placed in service after October 2, 2000, pneumatic testing must be performed in accordance with section 5.3 of API Spec 12 F.
- (b) For aboveground breakout tanks built to API Std 620 (incorporated by reference, see §195.3) and first placed in service after October 2, 2000, hydrostatic and pneumatic testing must be performed in accordance with section 7.18 of API Std 620.
- (c) For aboveground breakout tanks built to API Std 650 (incorporated by reference, see § [195.3](#)) that were first placed into service after October 2, 2000, testing must be conducted in accordance with Sections 7.3.6 and 7.3.7 of API Std 650.
- (d) For aboveground atmospheric pressure breakout tanks constructed of carbon and low alloy steel, welded or riveted, and non-refrigerated tanks built to API Std 650 or its predecessor Standard 12 C that are returned to service after October 2, 2000, the necessity for the hydrostatic testing of repair, alteration, and reconstruction is covered in Section 12.3 of API Std 653.
- (e) For aboveground breakout tanks built to API Std 2510 (incorporated by reference, see §195.3) and first placed in service after October 2, 2000, pressure testing must be performed in accordance with 2007 ASME Boiler and Pressure Vessel Code (BPVC) (Section VIII, Division 1 or 2).

[Amdt. 195-66, 64 FR 15926, Apr. 2, 1999; Amdt. 195-86, 71 FR 33402, June 9, 2006; Amdt. 195-94, 75 FR 48593, Aug. 11, 2010; Amdt. 195-99, 80 FR 168, Jan. 5, 2015; Amdt. 195-100, 80 FR 12762, Mar. 11, 2015; Amdt. 195-107, 89 FR 33264, Apr. 29, 2024]

§195.308 Testing of tie-ins.

Pipe associated with tie-ins must be pressure tested, either with the section to be tied in or separately.

[Amdt. 195-22, 46 FR 38360, July 27, 1981, as amended by Amdt. 195-51, 59 FR 29385, June 7, 1994]

§195.310 Records.

- (a) A record must be made of each pressure test required by this subpart, and the record of the latest test must be retained as long as the facility tested is in use.
- (b) The record required by paragraph (a) of this section must include:
 - (1) The pressure recording charts;
 - (2) Test instrument calibration data;
 - (3) The name of the operator, the name of the person responsible for making the test, and the name of the test company used, if any;
 - (4) The date and time of the test;
 - (5) The minimum test pressure;
 - (6) The test medium;
 - (7) A description of the facility tested and the test apparatus;
 - (8) An explanation of any pressure discontinuities, including test failures, that appear on the pressure recording charts; and,
 - (9) Where elevation differences in the section under test exceed 100 feet (30 meters), a profile of the pipeline that shows the elevation and test sites over the entire length of the test section.
 - (10) Temperature of the test medium or pipe during the test period.

[Amdt. 195-34, 50 FR 34474, Aug. 26, 1985, as amended by Amdt. 195-51, 59 FR 29385, June 7, 1994; Amdt. 195-63, 63 FR 37506, July 13, 1998; Amdt. 195-78, 68 FR 53528, Sept. 11, 2003]

SubPart F - Operation and Maintenance (§§400-454)

SubPart F -Operation and Maintenance

- §195.400 [Scope.](#)
- §195.401 [General requirements.](#)
- §195.402 [Procedural manual for operations, maintenance, and emergencies.](#)
- §195.403 [Training.](#)
- §195.404 [Maps and Records.](#)
- §195.405 [Protection against ignitions and safe access/egress involving floating roofs](#)
- §195.406 [Maximum operating pressure.](#)
- §195.408 [Communications.](#)
- §195.410 [Line markers.](#)
- §195.412 [Inspection of rights-of-way and crossings under navigable waters.](#)
- §195.413 [Underwater inspection and reburial of pipelines in the Gulf of Mexico and its inlets.](#)
- §195.414 [Inspections of pipelines in areas affected by extreme weather and natural disasters.](#)
- §195.416 [Pipeline assessments.](#)
- §195.417 [Notification of potential rupture.](#)
- §195.418 [Valves: Onshore valve shut-off for rupture mitigation.](#)
- §195.419 [Valve capabilities.](#)
- §195.420 [Valve maintenance.](#)
- §195.422 [Pipeline repairs.](#)
- §195.424 [Pipe movement.](#)
- §195.426 [Scraper and sphere facilities.](#)
- §195.428 [Overpressure safety devices and overfill protection systems](#)
- §195.430 [Firefighting equipment.](#)
- §195.432 [Inspection of in-service breakout tanks.](#)
- §195.434 [Signs.](#)
- §195.436 [Security of facilities.](#)
- §195.438 [Smoking or open flames.](#)
- §195.440 [Public awareness](#)
- §195.442 [Damage Prevention Program](#)
- §195.444 [Leak detection.](#)
- §195.446 [Control room management.](#)
- §195.450 [High Consequence Areas - Definitions](#)
- §195.452 [Pipeline integrity management in high consequence areas](#)
- §195.454 [Integrity assessments for certain underwater hazardous liquid pipeline facilities located in high consequence areas.](#)

§195.400 Scope.

This subpart prescribes minimum requirements for operating and maintaining pipeline systems constructed with steel pipe.

§195.401 General requirements.

- (a) No operator may operate or maintain its pipeline systems at a level of safety lower than that required by this subpart and the procedures it is required to establish under §195.402(a) of this subpart.
- (b) An operator must make repairs on its pipeline system according to the following requirements:
 - (1) *Non Integrity management repairs.* Whenever an operator discovers any condition that could adversely affect the safe operation of its pipeline system, it must correct the condition within a reasonable time. However, if the condition is of such a nature that it presents an immediate hazard to persons or property, the operator may not operate the affected part of the system until it has corrected the unsafe condition.
 - (2) *Integrity management repairs.* When an operator discovers a condition on a pipeline covered under § 195.452, the operator must correct the condition as prescribed in § 195.452(h).
 - (3) *Prioritizing repairs.* An operator must consider the risk to people, property, and the environment in prioritizing the correction of any conditions referenced in paragraphs (b)(1) and (2) of this section.
- (c) Except as provided in [§195.5](#), no operator may operate any part of any of the following pipelines unless it was designed and constructed as required by this part:
 - (1) An interstate pipeline, other than a low-stress pipeline, on which construction was begun after March 31, 1970, that transports hazardous liquid.
 - (2) An interstate offshore gathering line, other than a low-stress pipeline, on which construction was begun after July 31, 1977, that transports hazardous liquid.
 - (3) An intrastate pipeline, other than a low-stress pipeline, on which construction was begun after October 20, 1985, that transports hazardous liquid.
 - (4) A pipeline on which construction was begun after July 11, 1991, that transports carbon dioxide.
 - (5) A low-stress pipeline on which construction was begun after August 10, 1994.

[Amdt. 195-22, 46 FR 38360, July 27, 1981, as amended by Amdt. 195-33, 50 FR 15899, Apr. 23, 1985; Amdt. 195-33A, 50 FR 39008, Sept. 26, 1985; Amdt. 195-36, 51 FR 15008, Apr. 22, 1986; Amdt. 195-45, 56 FR 26926, June 12, 1991; Amdt. 195-53, 59 FR 35471, July 12, 1994; Amdt. 195-94, 75 FR 48607, Aug. 11, 2010; Amdt. 195-102, 84 FR 52295, Oct. 1, 2019]

§195.402 Procedural manual for operations, maintenance, and emergencies.

- (a) General. Each operator shall prepare and follow for each pipeline system a manual of written procedures for conducting normal operations and maintenance activities and handling abnormal operations and emergencies. This manual shall be reviewed at intervals not exceeding 15 months, but at least once each calendar year, and appropriate changes made as necessary to insure that the manual is effective. This manual shall be prepared before initial operations of a pipeline system commence, and appropriate parts shall be kept at locations where operations and maintenance activities are conducted.
- (b) The Associate Administrator or the State Agency that has submitted a current certification under the pipeline safety laws (49 U.S.C. 60101 et seq.) with respect to the pipeline facility governed by an operator's plans and procedures may, after notice and opportunity for hearing as provided in 49 CFR 190.206 or the relevant State procedures, require the operator to amend its plans and procedures as necessary to provide a reasonable level of safety.

- (c) Maintenance and normal operations. The manual required by paragraph (a) of this section must include procedures for the following to provide safety during maintenance and normal operations:
- (1) Making construction records, maps, and operating history available as necessary for safe operation and maintenance.
 - (2) Gathering of data needed for reporting accidents under [Subpart B](#) of this part in a timely and effective manner.
 - (3) Operating, maintaining, and repairing the pipeline system in accordance with each of the requirements of this subpart and [subpart H](#) of this part.
 - (4) Determining which pipeline facilities are in areas that would require an immediate response by the operator to prevent hazards to the public, property, or the environment if the facilities failed or malfunctioned, including segments that could affect high-consequence areas (HCA) or are in HCAs, and valves specified in § [195.418](#) or § [195.452](#)(i)(4).
 - (5) Investigating and analyzing pipeline accidents and failures, including sending the failed pipe, component, or equipment for laboratory testing or examination where appropriate, to determine the cause(s) and contributing factors of the failure and to minimize the possibility of a recurrence.
 - (i) Post-failure and -accident lessons learned. Each operator must develop, implement, and incorporate lessons learned from a post-failure and accident review into its written procedures, including in pertinent operator personnel training and qualifications programs, and in design, construction, testing, maintenance, operations, and emergency procedure manuals and specifications.
 - (ii) Analysis of rupture and valve shut-offs; preventive and mitigative measures. If a failure or accident on an onshore hazardous liquid or carbon dioxide pipeline involves the closure of a rupture- mitigation valve (RMV), as defined in § [195.2](#), or the closure of an alternative equivalent technology, the operator of the pipeline must also conduct a post-failure or post-accident analysis of all the factors that may have impacted the release volume and the consequences of the release, and identify and implement operations and maintenance measures to minimize the consequences of a future failure or accident. The analysis must include all relevant factors impacting the release volume and the consequences, including, but not limited to, the following:
 - (A) Detection, identification, operational response, system shut- off, and emergency- response communications, based on the type and volume of the release or failure event;
 - (B) Appropriateness and effectiveness of procedures and pipeline systems, including supervisory control and data acquisition (SCADA), communications, valve shut-off, and operator personnel;
 - (C) Actual response time from identifying a rupture following a notification of potential rupture, as defined at § [195.2](#), to initiation of mitigative actions and isolation of the segment, and the appropriateness and effectiveness of the mitigative actions taken;
 - (D) Location and timeliness of actuation of all RMVs or alternative equivalent technologies; and
 - (E) All other factors the operator deems appropriate.
 - (iii) Rupture post-failure and accident summary. If a failure or accident on an onshore hazardous liquid or carbon dioxide pipeline involves the identification of a rupture following a notification of potential rupture; the closure of an RMV, as those terms are defined in § [195.2](#); or the closure of an alternative equivalent technology, the operator must complete a

summary of the post-failure or -accident review required by paragraph (c)(5)(ii) of this section within 90 days of the failure or accident. While the investigation is pending, the operator must conduct quarterly status reviews until the investigation is completed and a final post-failure or -accident review is prepared. The final post-failure or -accident summary and all other reviews and analyses produced under the requirements of this section must be reviewed, dated, and signed by the operator's appropriate senior executive officer. An operator must keep, for the useful life of the pipeline, the final post-failure or -accident summary, all investigation and analysis documents used to prepare it, and records of lessons learned.

- (6) Minimizing the potential for hazards identified under paragraph (c)(4) of this section and the possibility of recurrence of accidents analyzed under paragraph (c)(5) of this section.
- (7) Starting up and shutting down any part of the pipeline system in a manner designed to assure operation within the limits prescribed by [§195.406](#), consider the hazardous liquid or carbon dioxide in transportation, variations in altitude along the pipeline, and pressure monitoring and control devices.
- (8) In the case of a pipeline that is not equipped to fail safe, monitoring from an attended location pipeline pressure during startup until steady state pressure and flow conditions are reached and during shut-in to assure operation within limits prescribed by [§195.406](#).
- (9) In the case of facilities not equipped to fail safe that are identified under paragraph 195.402(c)(4) or that control receipt and delivery of the hazardous liquid or carbon dioxide, detecting abnormal operating conditions by monitoring pressure, temperature, flow or other appropriate operational data and transmitting this data to an attended location.
- (10) Abandoning pipeline facilities, including safe disconnection from an operating pipeline system, purging of combustibles, and sealing abandoned facilities left in place to minimize safety and environmental hazards. For each abandoned offshore pipeline facility or each abandoned onshore pipeline facility that crosses over, under or through commercially navigable waterways the last operator of that facility must file a report upon abandonment of that facility in accordance with [§195.59](#) of this part.
- (11) Minimizing the likelihood of accidental ignition of vapors in areas near facilities identified under paragraph (c)(4) of this section where the potential exists for the presence of flammable liquids or gases.
- (12) Establishing and maintaining adequate means of communication with the appropriate public safety answering point (i.e., 9-1-1 emergency call center), where direct access to a 9-1-1 emergency call center is available from the location of the pipeline, and fire, police, and other public officials. Operators must determine the responsibilities, resources, jurisdictional area(s), and emergency contact telephone numbers for both local and out-of-area calls of each Federal, State, and local government organization that may respond to a pipeline emergency, and inform the officials about the operator's ability to respond to the pipeline emergency and means of communication during emergencies. Operators may establish liaison with the appropriate local emergency coordinating agencies, such as 9-1-1 emergency call centers or county emergency managers, in lieu of communicating individually with each fire, police, or other public entity.
- (13) Periodically reviewing the work done by operator personnel to determine the effectiveness of the procedures used in normal operation and maintenance and taking corrective action where deficiencies are found.
- (14) Taking adequate precautions in excavated trenches to protect personnel from the hazards of unsafe accumulations of vapor or gas, and making available when needed at the excavation, emergency rescue equipment, including a breathing apparatus and, a rescue harness and line.

- (15) Implementing the applicable control room management procedures required by § [195.446](#).
- (d) Abnormal operation. The manual required by paragraph (a) of this section must include procedures for the following to provide safety when operating design limits have been exceeded:
- (1) Responding to, investigating, and correcting the cause of:
 - (i) Unintended closure of valves or shutdowns;
 - (ii) Increase or decrease in pressure or flow rate outside normal operating limits;
 - (iii) Loss of communications;
 - (iv) Operation of any safety device;
 - (v) Any other malfunction of a component, deviation from normal operation, or personnel error which could cause a hazard to persons or property.
 - (2) Checking variations from normal operation after abnormal operation has ended at sufficient critical locations in the system to determine continued integrity and safe operation.
 - (3) Correcting variations from normal operation of pressure and flow equipment and controls.
 - (4) Notifying responsible operator personnel when notice of an abnormal operation is received.
 - (5) Periodically reviewing the response of operator personnel to determine the effectiveness of the procedures controlling abnormal operation and taking corrective action where deficiencies are found.
- (e) Emergencies. The manual required by paragraph (a) of this section must include procedures for the following to provide safety when an emergency condition occurs:
- (1) Receiving, identifying, and classifying notices of events that need immediate response by the operator or notice to the appropriate public safety answering point (i.e., 9-1-1 emergency call center), where direct access to a 9-1-1 emergency call center is available from the location of the pipeline, and fire, police, and other appropriate public officials, and communicating this information to appropriate operator personnel for prompt corrective action. Operators may establish liaison with the appropriate local emergency coordinating agencies, such as 9-1-1 emergency call centers or county emergency managers, in lieu of communicating individually with each fire, police, or other public entity.
 - (2) Prompt and effective response to a notice of each type emergency, including fire or explosion occurring near or directly involving a pipeline facility, accidental release of hazardous liquid or carbon dioxide from a pipeline facility, operational failure causing a hazardous condition, and natural disaster affecting pipeline facilities.
 - (3) Having personnel, equipment, instruments, tools, and material available as needed at the scene of an emergency.
 - (4) Taking necessary actions, including but not limited to, emergency shutdown, valve shut-off, or pressure reduction, in any section of the operator's pipeline system, to minimize hazards of released hazardous liquid or carbon dioxide to life, property, or the environment. Each operator must also develop written rupture identification procedures to evaluate and identify whether a notification of potential rupture, as defined in § [195.2](#), is an actual rupture event or non-rupture event. These procedures must, at a minimum, specify the sources of information, operational factors, and other criteria that operator personnel use to evaluate a notification of potential rupture, as defined at § 195.2. For operators installing valves in accordance with § [195.258\(c\)](#), § 195.258(d), or that are subject to the requirements in § [195.418](#), those procedures should provide for rupture identification as soon as practicable.
 - (5) Control of released hazardous liquid or carbon dioxide at an accident scene to minimize the hazards, including possible intentional ignition in the cases of flammable highly volatile liquid.

- (6) Minimization of public exposure to injury and probability of accidental ignition by assisting with evacuation of residents and assisting with halting traffic on roads and railroads in the affected area, or taking other appropriate action.
 - (7) Notifying the appropriate public safety answering point (i.e., 9-1-1 emergency call center), where direct access to a 9-1-1 emergency call center is available from the location of the pipeline, and fire, police, and other public officials, of hazardous liquid or carbon dioxide pipeline emergencies to coordinate and share information to determine the location of the release, including both planned responses and actual responses during an emergency, and any additional precautions necessary for an emergency involving a pipeline transporting a highly volatile liquid (HVL). The operator must immediately and directly notify the appropriate public safety answering point or other coordinating agency for the communities and jurisdiction(s) in which the pipeline is located after notification of potential rupture, as defined at § [195.2](#), has occurred to coordinate and share information to determine the location of the release, regardless of whether the segment is subject to the requirements of § [195.258](#) (c) or (d), § [195.418](#), or § [195.419](#).
 - (8) In the case of failure of a pipeline system transporting a highly volatile liquid, use of appropriate instruments to assess the extent and coverage of the vapor cloud and determine the hazardous areas.
 - (9) Providing for a post accident review of employee activities to determine whether the procedures were effective in each emergency and taking corrective action where deficiencies are found.
 - (10) Actions required to be taken by a controller during an emergency, in accordance with the operator's emergency plans and §§ [195.418](#) and [195.446](#).
- (f) Safety-related condition reports. The manual required by paragraph (a) of this section must include instructions enabling personnel who perform operation and maintenance activities to recognize conditions that potentially may be safety-related conditions that are subject to the reporting requirements of [§195.55](#).
- (g) *Exception.* An operator of a gathering line must only comply with the requirements of § 195.402 effective as of October 4, 2022, and need not comply with the other requirements of this section.

EFFECTIVE DATE NOTE: The effective date of §195.402 with respect to intrastate pipelines is April 23, 1987. See Amdt. 195-33, published at 50 FR 15895, Apr. 23, 1985.

[Amdt. 195-22, 46 FR 38360, July 27, 1981; 47 FR 32721, July 29, 1982, as amended by Amdt. 195-24, 47 FR 46852, Oct. 21, 1982; Amdt. 195-39, 53 FR 24951, July 1, 1988; Amdt. 195-45, 56 FR 26926, June 12, 1991; Amdt. 195-46, 56 FR 31090, July 9, 1991; Amdt. 195-49, 59 FR 6585, Feb. 11, 1994; Amdt. 195-55, 61 FR 18518, Apr. 26, 1996; Amdt. 195-69, 65 FR 54444, Sept. 8, 2000; Amdt. 195-173, 66 FR 67004, Dec. 27, 2001; Amdt. 195-93, 74 FR 63329, Dec. 3, 2009; Amdt. 195-98, 78 FR 58915, Sept. 25, 2013; Amdt 195-105, 87 FR 20940, Apr. 8, 2022; Amdt. 195-106, 88 FR 50056, Aug. 1, 2023]

§195.403 Emergency response training.

- (a) Each operator shall establish and conduct a continuing training program to instruct emergency response personnel to:
 - (1) Carry out the emergency procedures established under 195.402 that relate to their assignments;
 - (2) Know the characteristics and hazards of the hazardous liquids or carbon dioxide transported, including, in case of flammable HVL, flammability of mixtures with air, odorless vapors, and water reactions;

- (3) Recognize conditions that are likely to cause emergencies, predict the consequences of facility malfunctions or failures and hazardous liquids or carbon dioxide spills, and take appropriate corrective action;
 - (4) Take steps necessary to control any accidental release of hazardous liquid or carbon dioxide and to minimize the potential for fire, explosion, toxicity, or environmental damage; and
 - (5) Learn the potential causes, types, sizes, and consequences of fire and the appropriate use of portable fire extinguishers and other on-site fire control equipment, involving, where feasible, a simulated pipeline emergency condition.
- (b) At the intervals not exceeding 15 months, but at least once each calendar year, each operator shall:
- (1) Review with personnel their performance in meeting the objectives of the emergency response training program set forth in paragraph (a) of this section; and
 - (2) Make appropriate changes to the emergency response training program as necessary to ensure that it is effective.
- (c) Each operator shall require and verify that its supervisors maintain a thorough knowledge of that portion of the emergency response procedures established under 195.402 for which they are responsible to ensure compliance.

[Amdt. 195-67, 64 FR 46866, Aug. 27, 1999, as amended at Amdt. 195-78, 68 FR 53528, Sept. 11, 2003]

§195.404 Maps and records.

- (a) Each operator shall maintain current maps and records of its pipeline systems that include at least the following information:
- (1) Location and identification of the following pipeline facilities:
 - (i) Breakout tanks;
 - (ii) Pump stations;
 - (iii) Scraper and sphere facilities;
 - (iv) Pipeline valves;
 - (v) Facilities to which §195.402(c)(9) applies;
 - (vi) Rights-of-way; and
 - (vii) Safety devices to which [§195.428](#) applies.
 - (2) All crossings of public roads, railroads, rivers, buried utilities, and foreign pipelines.
 - (3) The maximum operating pressure of each pipeline.
 - (4) The diameter, grade, type, and nominal wall thickness of all pipe.
- (b) Each operator shall maintain for at least 3 years daily operating records that indicate-
- (1) The discharge pressure at each pump station; and
 - (2) Any emergency or abnormal operation to which the procedures under §195.402 apply.
- (c) Each operator shall maintain the following records for the periods specified:
- (1) The date, location, and description of each repair made to pipe shall be maintained for the useful life of the pipe.
 - (2) The date, location, and description of each repair made to parts of the pipeline system other than pipe shall be maintained for at least 1 year.

- (3) A record of each inspection and test required by this subpart shall be maintained for at least 2 years or until the next inspection or test is performed, whichever is longer.

[Amdt. 195-22, 46 FR 38360, July 27, 1981, as amended by Amdt. 195-34, 50 FR 34474, Aug. 26, 1985; Amdt. 195-173, 66 FR 67004, Dec. 27, 2001]

§195.405 Protection against ignitions and safe access/egress involving floating roofs.

This section has been amended by Amdt. 195-107, eff. 6/28/24.

- (a) After October 2, 2000, protection provided against ignitions arising out of static electricity, lightning, and stray currents during operation and maintenance activities involving aboveground breakout tanks must be in accordance with API RP 2003 (incorporated by reference, see [§195.3](#)), unless the operator notes in the procedural manual (§195.402(c)) why compliance with all or certain provisions of API RP 2003 is not necessary for the safety of a particular breakout tank.
- (b) The hazards associated with access/egress onto floating roofs of in-service aboveground breakout tanks to perform inspection, service, maintenance, or repair activities (other than specified general considerations, specified routine tasks or entering tanks removed from service for cleaning) are addressed in API RP 2026 (incorporated by reference, see §195.3). After October 2, 2000, the operator must review and consider the potentially hazardous conditions, safety practices, and procedures in API RP 2026 for inclusion in the procedure manual (§195.402(c)).

[Amdt. 195-66, 64 FR 15926, Apr. 2, 1999; Amdt. 195-99, 80 FR 168, Jan. 5, 2015, Amdt. 195-99c, 80 FR 46848, Aug. 6, 2015; Amdt. 195-107, 89 FR 33264, Apr. 29, 2024]

§195.406 Maximum operating pressure.

This section has been amended by Amdt. 195-107, eff. 6/28/24.

- (a) Except for surge pressures and other variations from normal operations, no operator may operate a pipeline at a pressure that exceeds any of the following:
- (1) The internal design pressure of the pipe determined in accordance with [§195.106](#). However, for steel pipe in pipelines being converted under [§195.5](#), if one or more factors of the design formula ([§195.106](#)) are unknown, one of the following pressures is to be used as design pressure:
 - (i) Eighty percent of the first test pressure that produces yield under section N5.0 of Appendix N of ASME B31.8 (incorporated by reference, see [§195.3](#)), reduced by the appropriate factors in [§§195.106\(a\)](#) and (e); or
 - (ii) If the pipe is 12¾ in (324 mm) or less outside diameter and is not tested to yield under this paragraph, 200 p.s.i. (1379 kPa) gage.
 - (2) The design pressure of any other component of the pipeline.
 - (3) Eighty percent of the test pressure for any part of the pipeline which has been pressure tested under [Subpart E](#) of this part.

- (4) Eighty percent of the factory test pressure or of the prototype test pressure for any individually installed component which is excepted from testing under [§195.305](#).
 - (5) For pipelines under §§[195.302](#)(b)(1) and (b)(2)(i) that have not been pressure tested under Subpart E of this part, 80 percent of the test pressure or highest operating pressure to which the pipeline was subjected for 4 or more continuous hours that can be demonstrated by recording charts or logs made at the time the test or operations were conducted.
- (b) No operator may permit the pressure in a pipeline during surges or other variations from normal operations to exceed 110 percent of the operating pressure limit established under paragraph (a) of this section. Each operator must provide adequate controls and protective equipment to control the pressure within this limit.

[Amdt. 195-2, 35 FR 17183, Nov. 7, 1970 as amended by Amdt. 195-17, 45 FR 59161, Sept. 8, 1980; Amdt. 195-22, 46 FR 38357, July 27, 1981; Amdt. 195-33, 50 FR 15895, Apr. 23, 1985; Amdt. 195-33c, 50 FR 38659, Sept. 24, 1985; Amdt. 195-51, 59 FR 29379, June 7, 1994; Amdt. 195-52, 59 FR 33388, June 28, 1994; Amdt. 195-63, 63 FR 37500, July 13, 1998; Amdt. 195-65, 63 FR 59475, Nov. 4, 1998; Amdt. 195-99, 80 FR 168, Jan. 5, 2015; Amdt. 195-107, 89 FR 33264, Apr. 29, 2024]

§195.408 Communications.

- (a) Each operator must have a communication system to provide for the transmission of information needed for the safe operation of its pipeline system.
- (b) The communication system required by paragraph (a) of this section must, as a minimum, include means for:
 - (1) Monitoring operational data as required by §195.402(c)(9);
 - (2) Receiving notices from operator personnel, the public, and public authorities of abnormal or emergency conditions and sending this information to appropriate personnel or government agencies for corrective action;
 - (3) Conducting two-way vocal communication between a control center and the scene of abnormal operations and emergencies; and
 - (4) Providing communication with fire, police, and other appropriate public officials during emergency conditions, including a natural disaster.

§195.410 Line markers.

- (a) Except as provided in paragraph (b) of this section, each operator shall place and maintain line markers over each buried pipeline in accordance with the following:
 - (1) Markers must be located at each public road crossing, at each railroad crossing, and in sufficient number along the remainder of each buried line so that its location is accurately known.
 - (2) The marker must state at least the following on a background of sharply contrasting color:
 - (i) The word "Warning," "Caution," or "Danger" followed by the words "Petroleum (or the name of the hazardous liquid transported) Pipeline", or "Carbon Dioxide Pipeline," all of which, except for markers in heavily developed urban areas, must be in letters at least 1 inch (25 millimeters) high with an approximate stroke of 1/4 inch (6.4 millimeters).
 - (ii) The name of the operator and a telephone number (including area code) where the operator can be reached at all times.

- (b) Line markers are not required for buried pipelines located-
 - (1) Offshore or at crossings of or under waterways and other bodies of water; or
 - (2) In heavily developed urban areas such as downtown business centers where-
 - (i) The placement of markers is impractical and would not serve the purpose for which markers are intended; and
 - (ii) The local government maintains current substructure records.
- (c) Each operator shall provide line marking at locations where the line is above ground in areas that are accessible to the public.

[Amdt. 195-22, 46 FR 38360, July 27, 1981, as amended by Amdt. 195-27, 48 FR 25208, June 6, 1983; Amdt. 195-54, 60 FR 14650, Mar. 20, 1995; Amdt. 195-63, 63 FR 37506, July 13, 1998]

§195.412 Inspection of rights-of-way and crossings under navigable waters.

- (a) Each operator shall, at intervals not exceeding 3 weeks, but at least 26 times each calendar year, inspect the surface conditions on or adjacent to each pipeline right-of-way. Methods of inspection include walking, driving, flying or other appropriate means of traversing the right-of-way.
- (b) Except for offshore pipelines, each operator shall, at intervals not exceeding 5 years, inspect each crossing under a navigable waterway to determine the condition of the crossing.

[Amdt. 195-22, 46 FR 38360, July 27, 1981, as amended by Amdt. 195-24, 47 FR 46852, Oct. 21, 1982; Amdt. 195-52, 59 FR 33397, June 28, 1994]

§195.413 Underwater inspection and reburial of pipelines in the Gulf of Mexico and its inlets.

- (a) Except for gathering lines of 4 1/2 inches (114mm) nominal outside diameter or smaller, each operator shall prepare and follow a procedure to identify its pipelines in the Gulf of Mexico and its inlets in waters less than 15 feet (4.6 meters) deep as measured from mean low water that are at risk of being an exposed underwater pipeline or a hazard to navigation. The procedures must be in effect August 10, 2005.
- (b) Each operator shall conduct appropriate periodic underwater inspections of its pipelines in the Gulf of Mexico and its inlets in waters less than 15 feet (4.6 meters) deep as measured from mean low water based on the identified risk.
- (c) If an operator discovers that its pipeline is an exposed underwater pipeline or poses a hazard to navigation, the operator shall -
 - (1) Promptly, but not later than 24 hours after discovery, notify the National Response Center, telephone: 1-800-424-8802, of the location and, if available, the geographic coordinates of that pipeline.
 - (2) Promptly, but not later than 7 days after discovery, mark the location of the pipeline in accordance with 33 CFR Part 64 at the ends of the pipeline segment and at intervals of not over 500 yards (457 meters) long, except that a pipeline segment less than 200 yards (183 meters) long need only be marked at the center; and (3) Within 6 months after discovery, or not later than November 1 of the following year if the 6 month period is later than November 1 of the year of discovery, bury the pipeline so that the top of the pipe is 36 inches (914 millimeters)

below the underwater natural bottom (as determined by recognized and generally accepted practices) for normal excavation or 18 inches (457 millimeters) for rock excavation.

- (i) An operator may employ engineered alternatives to burial that meet or exceed the level of protection provided by burial.
- (ii) If an operator cannot obtain required state or Federal permits in time to comply with this section, it must notify OPS; specify whether the required permit is State or Federal; and, justify the delay.

[Amdt. 195-82, 69 FR 48407, Aug. 10, 2004]

§195.414 Inspections of pipelines in areas affected by extreme weather and natural disasters.

- (a) *General.* Following an extreme weather event or natural disaster that has the likelihood of damage to infrastructure by the scouring or movement of the soil surrounding the pipeline, such as a named tropical storm or hurricane; a flood that exceeds the river, shoreline, or creek high-water banks in the area of the pipeline; a landslide in the area of the pipeline; or an earthquake in the area of the pipeline, an operator must inspect all potentially affected pipeline facilities to detect conditions that could adversely affect the safe operation of that pipeline.
- (b) *Inspection method.* An operator must consider the nature of the event and the physical characteristics, operating conditions, location, and prior history of the affected pipeline in determining the appropriate method for performing the initial inspection to determine the extent of any damage and the need for the additional assessments required under paragraph (a) of this section.
- (c) *Time period.* The inspection required under paragraph (a) of this section must commence within 72 hours after the cessation of the event, defined as the point in time when the affected area can be safely accessed by the personnel and equipment required to perform the inspection as determined under paragraph (b) of this section. In the event that the operator is unable to commence the inspection due to the unavailability of personnel or equipment, the operator must notify the appropriate PHMSA Region Director as soon as practicable.
- (d) *Remedial action.* An operator must take prompt and appropriate remedial action to ensure the safe operation of a pipeline based on the information obtained as a result of performing the inspection required under paragraph (a) of this section. Such actions might include, but are not limited to:
 - (1) Reducing the operating pressure or shutting down the pipeline;
 - (2) Modifying, repairing, or replacing any damaged pipeline facilities;
 - (3) Preventing, mitigating, or eliminating any unsafe conditions in the pipeline right-of-way;
 - (4) Performing additional patrols, surveys, tests, or inspections;
 - (5) Implementing emergency response activities with Federal, State, or local personnel; and
 - (6) Notifying affected communities of the steps that can be taken to ensure public safety.

[Added at Amdt. 195-102, 84 FR 52260, Oct. 1, 2019]

§195.416 Pipeline assessments.

- (a) *Scope.* This section applies to onshore line pipe that can accommodate inspection by means of in-line inspection tools and is not subject to the integrity management requirements in §195.452.

- (b) *General.* An operator must perform an initial assessment of each of its pipeline segments by October 1, 2029, and perform periodic assessments of its pipeline segments at least once every 10 calendar years from the year of the prior assessment or as otherwise necessary to ensure public safety or the protection of the environment.
- (c) *Method.* Except as specified in paragraph (d) of this section, an operator must perform the integrity assessment for the range of relevant threats to the pipeline segment by the use of an appropriate in-line inspection tool(s). When performing an assessment using an in-line inspection tool, an operator must comply with §195.591. An operator must explicitly consider uncertainties in reported results (including tool tolerance, anomaly findings, and unity chart plots or other equivalent methods for determining uncertainties) in identifying anomalies. If this is impracticable based on operational limits, including operating pressure, low flow, and pipeline length or availability of in-line inspection tool technology for the pipe diameter, then the operator must perform the assessment using the appropriate method(s) in paragraphs (c)(1), (2), or (3) of this section for the range of relevant threats being assessed. The methods an operator selects to assess low-frequency electric resistance welded pipe, pipe with a seam factor less than 1.0 as defined in §195.106(e) or lap-welded pipe susceptible to longitudinal seam failure must be capable of assessing seam integrity, cracking, and of detecting corrosion and deformation anomalies. The following alternative assessment methods may be used as specified in this paragraph:
- (1) A pressure test conducted in accordance with [subpart E](#) of this part;
 - (2) External corrosion direct assessment in accordance with §195.588; or
 - (3) Other technology in accordance with paragraph (d).
- (d) *Other technology.* Operators may elect to use other technologies if the operator can demonstrate the technology can provide an equivalent understanding of the condition of the line pipe for threat being assessed. An operator choosing this option must notify the Office of Pipeline Safety (OPS) 90 days before conducting the assessment by:
- (1) Sending the notification, along with the information required to demonstrate compliance with this paragraph, to the Information Resources Manager, Office of Pipeline Safety, Pipeline and Hazardous Materials Safety Administration, 1200 New Jersey Avenue SE, Washington, DC 20590; or
 - (2) Sending the notification, along with the information required to demonstrate compliance with this paragraph, to the Information Resources Manager by facsimile to (202) 366-7128.
 - (3) Prior to conducting the "other technology" assessments, the operator must receive a notice of "no objection" from the PHMSA Information Services Manager or Designee.
- (e) *Data analysis.* A person qualified by knowledge, training, and experience must analyze the data obtained from an assessment performed under paragraph (b) of this section to determine if a condition could adversely affect the safe operation of the pipeline. Operators must consider uncertainties in any reported results (including tool tolerance) as part of that analysis.
- (f) *Discovery of condition.* For purposes of §195.401(b)(1), discovery of a condition occurs when an operator has adequate information to determine that a condition presenting a potential threat to the integrity of the pipeline exists. An operator must promptly, but no later than 180 days after an assessment, obtain sufficient information about a condition to make that determination required under paragraph (e) of this section, unless the operator can demonstrate the 180-day interval is impracticable. If the operator believes that 180 days are impracticable to make a determination about a condition found during an assessment, the pipeline operator must notify PHMSA and provide an expected date when adequate information will become available. This notification must be made in accordance with §195.452 (m).

- (g) *Remediation.* An operator must comply with the requirements in §[195.401](#) if a condition that could adversely affect the safe operation of a pipeline is discovered in complying with paragraphs (e) and (f) of this section.
- (h) *Consideration of information.* An operator must consider all relevant information about a pipeline in complying with the requirements in paragraphs (a) through (g) of this section.

[Amdt. 195-102, 84 FR 52295, Oct. 1, 2019]

§195.417 Notification of potential rupture.

- (a) As used in this part, a notification of potential rupture means the notification to, or observation by, an operator (e.g., by or to its controller(s) in a control room, field personnel, nearby pipeline or utility personnel, the public, local responders, or public authorities) of one or more of the below indicia of a potential unintentional or uncontrolled release of a large volume of hazardous liquids or carbon dioxide from a pipeline:
 - (1) An unanticipated or unexplained pressure loss outside of the pipeline's normal operating pressures, as defined in the operator's written procedures. The operator must establish in its written procedures that an unanticipated or unplanned pressure loss is outside of the pipeline's normal operating pressures when there is a pressure loss greater than 10 percent occurring within a time interval of 15 minutes or less, unless the operator has documented in its written procedures the operational need for a greater pressure-change threshold due to pipeline flow dynamics (including changes in operating pressure, flow rate, or volume), that are caused by fluctuations in product demand, receipts, or deliveries;
 - (2) An unanticipated or unexplained flow rate change, pressure change, equipment function, or other pipeline instrumentation indication at the upstream or downstream station that may be representative of an event meeting paragraph (a)(1) of this section; or
 - (3) Any unanticipated or unexplained rapid release of a large volume of hazardous liquid or carbon dioxide, a fire, or an explosion, in the immediate vicinity of the pipeline.
- (b) A notification of potential rupture occurs when an operator first receives notice of or observes an event specified in paragraph (a) of this section.
- (c) The requirements of this section do not apply to gathering lines.

[Amdt. 195-105, 87 FR 20940, Apr. 8, 2022; Amdt. 195-106, 88 FR 50056, Aug. 1, 2023]

§195.418 Valves: Onshore valve shut-off for rupture mitigation.

- (a) *Applicability.* For newly constructed and entirely replaced onshore hazardous liquid or carbon dioxide pipeline segments, as defined at § [195.2](#), with diameters of 6 inches or greater that could affect high-consequence areas or are located in high consequence areas (HCA), and that have been installed after April 10, 2023, an operator must install or use existing rupture-mitigation valves (RMV), as defined at § 195.2, or alternative equivalent technologies according to the requirements

of this section and § [195.419](#). RMVs and alternative equivalent technologies must be operational within 14 days of placing the new or replaced pipeline segment in service. An operator may request an extension of this 14-day operation requirement if it can demonstrate to PHMSA, in accordance with the notification procedures in § [195.18](#), that application of that requirement would be economically, technically, or operationally infeasible. The requirements of this section apply to all applicable pipe replacements, even those that do not otherwise directly involve the addition or replacement of a valve.

(b) Maximum spacing between valves. RMVs and alternative equivalent technology must be installed in accordance with the following requirements:

(1) *Shut-off Segment*. For purposes of this section, a “shut-off segment” means the segment of pipeline located between the upstream valve closest to the upstream endpoint of the replaced pipeline segment in the HCA or the pipeline segment that could affect an HCA and the downstream valve closest to the downstream endpoint of the replaced pipeline segment of the HCA or the pipeline segment that could affect an HCA so that the entirety of the segment that could affect the HCA or the segment within the HCA is between at least two RMVs or alternative equivalent technologies. If any crossover or lateral pipe for commodity receipts or deliveries connects to the replaced segment between the upstream and downstream valves, the shut-off segment also extends to a valve on the crossover connection(s) or lateral(s), such that, when all valves are closed, there is no flow path for commodity to be transported to the rupture site (except for residual liquids already in the shut-off segment). Multiple segments that could affect HCAs or are in HCAs may be contained within a single shut-off segment. All entirely replaced onshore hazardous liquid or carbon dioxide pipeline segments, as defined in § [195.2](#), that could affect or are in an HCA must include a minimum of one valve that meets the requirements of this section and § [195.419](#). The operator is not required to select the closest valve to the shut-off segment as the RMV or alternative equivalent technology. An operator may use a manual pump station valve at a continuously manned station as an alternative equivalent technology. Such a manual valve used as an alternative equivalent technology would not require a notification to PHMSA in accordance with § [195.18](#).

(2) *Shut-off segment valve spacing*. Pipeline segments subject to paragraph (a) of this section must be protected on the upstream and downstream side with RMVs or alternative equivalent technologies. The distance between RMVs or alternative equivalent technologies must not exceed:

- (i) For pipeline segments carrying non-highly volatile liquids (HVL): 15 miles, with a maximum distance not to exceed 7 1/2 miles from the endpoints of a shut-off segment: or
- (ii) For pipeline segments carrying HVLs: 7 1/2 miles. The maximum valve spacing intervals for these valves may be increased by 1.25 times the spacing distance, up to a 9 3/8-mile spacing at an endpoint, provided the operator notify PHMSA in accordance with § [195.260](#) (g).

((3) *Laterals*. Laterals extending from shut-off segments that contribute less than 5 percent of the total shut-off segment volume may have RMVs or alternative equivalent technologies that meet the actuation requirements of this section at locations other than mainline receipt/delivery points, as long as all of these laterals contributing hazardous liquid or carbon dioxide volumes to the shut-off segment do not contribute more than 5 percent of the total shut-off segment volume, based upon maximum flow volume at the operating pressure. A check valve may be used as an alternative equivalent technology where it is positioned to stop flow into the lateral. Check valves used as an alternative equivalent technology in accordance with this paragraph (b)(3) are not subject to § [195.419](#) but must be inspected, operated, and remediated in

accordance with § [195.420](#), including for closure and leakage, to ensure operational reliability. An operator using such a valve as an alternative equivalent technology must submit a request to PHMSA in accordance with § [195.18](#).

(4) *Crossovers*. An operator may use a manual valve as an alternative equivalent technology for a crossover connection if, during normal operations, the valve is closed to prevent the flow of hazardous liquid or carbon dioxide with a locking device or other means designed to prevent the opening of the valve by persons other than those authorized by the operator. The operator must document that the valve has been closed and locked in accordance with the operator's lock-out and tag-out procedures to prevent the flow of hazardous liquid or carbon dioxide. An operator using a such a valve as an alternative equivalent technology must submit a request to PHMSA in accordance with § [195.18](#).

(c) Manual operation upon identification of a rupture. Operators using a manual valve as an alternative equivalent technology pursuant to paragraph (a) of this section must develop and implement operating procedures and appropriately designate and locate nearby personnel to ensure valve shut-off in accordance with this section and § [195.419](#). Manual operation of valves must include time for the assembly of necessary operating personnel, the acquisition of necessary tools and equipment, driving time under heavy traffic conditions and at the posted speed limit, walking time to access the valve, and time to manually shut off all valves, not to exceed the response time in § [195.419](#)(b).

(d) *Exception*. The requirements of this section do not apply to gathering lines.

[Amdt. 195-105, 87 FR 20940, Apr. 8, 2022; Amdt. 195-106, 88 FR 50056, Aug. 1, 2023]

§195.419 Valve capabilities.

(a) *Scope*. The requirements in this section apply to rupture- mitigation valves (RMV), as defined in § [195.2](#), or alternative equivalent technology, installed pursuant to §§ [195.258](#) and [195.418](#).

(b) *Rupture identification and valve shut-off time*. If an operator observes or is notified of a release of hazardous liquid or carbon dioxide that may be representative of an unintentional or uncontrolled release event meeting a notification of potential rupture (see §§ 195.2 and [195.417](#)), including any unexplained flow rate changes, pressure changes, equipment functions, or other pipeline instrumentation indications observed by the operator, the operator must, as soon as practicable but within 30 minutes of rupture identification (see § [195.402](#)(e)(4)), identify the rupture and fully close any RMVs or alternative equivalent technologies necessary to minimize the volume of hazardous liquid or carbon dioxide released from a pipeline and mitigate the consequences of a rupture.

(c) *Valve shut-off capability*. A valve must have the actuation capability necessary to close an RMV or alternative equivalent technology to mitigate the consequences of a rupture in accordance with the requirements of this section.

(d) *Valve monitoring and operational capabilities*. An RMV, as defined in § 195.2, or alternative equivalent technology, must be capable of being monitored or controlled by either remote or onsite personnel as follows:

(1) Operated during normal, abnormal, and emergency operating conditions;

- (2) Monitored for valve status (i.e., open, closed, or partial closed/open), upstream pressure, and downstream pressure. For automatic shut-off valves (ASV), an operator does not need to monitor remotely a valve's status if the operator has the capability to monitor pressures or flow rate within each pipeline segment located between RMVs or alternative equivalent technologies to identify and locate a rupture. Pipeline segments that use an alternative equivalent technology must have the capability to monitor pressures and hazardous liquid or carbon dioxide flow rates on the pipeline in order to identify and locate a rupture; and
 - (3) Have a back-up power source to maintain supervisory control and data acquisition (SCADA) systems or other remote communications for remote-control valve (RCV) or ASV operational status or be monitored and controlled by on-site personnel.
- (e) Monitoring of valve shut-off response status. The position and operational status of an RMV must be appropriately monitored through electronic communication with remote instrumentation or other equivalent means. An operator does not need to monitor remotely an ASV's status if the operator has the capability to monitor pressures or hazardous liquid or carbon dioxide s flow rate on the pipeline to identify and locate a rupture.
- (f) Flow modeling for automatic shut-off valves. Prior to using an ASV as an RMV, the operator must conduct flow modeling for the shut-off segment and any laterals that feed the shut-off segment, so that the valve will close within 30 minutes or less following rupture identification, consistent with the operator's procedures, and in accordance with § [195.2](#) and this section. The flow modeling must include the anticipated maximum, normal, or any other flow volumes, pressures, or other operating conditions that may be encountered during the year, not to exceed a period of 15 months, and it must be modeled for the flow between the RMVs or alternative equivalent technologies, and any looped pipelines or hazardous liquid or carbon dioxide receipt tie-ins. If operating conditions change that could affect the ASV set pressures and the 30-minute valve closure time following a notification of potential rupture, as defined at § 195.2, an operator must conduct a new flow model and reset the ASV set pressures prior to the next review for ASV set pressures in accordance with § [195.420](#). The flow model must include a time/pressure chart for the segment containing the ASV if a rupture event occurs. An operator must conduct this flow modeling prior to making flow condition changes in a manner that could render the 30-minute valve closure time unachievable.
- (g) Pipelines not affecting HCAs. For pipeline segments that are not in a high-consequence area (HCA) or that could not affect an HCA, an operator submitting a notification pursuant to §§ [195.18](#) and [195.258](#) for use of manual valves as an alternative equivalent technology may also request an exemption from the valve operation requirements of § [195.419](#)(b).

[Amdt. 195-105, 87 FR 20940, Apr. 8, 2022]

§195.420 Valve maintenance.

- (a) Each operator shall maintain each valve that is necessary for the safe operation of its pipeline systems in good working order at all times.
- (b) Each operator must, at least twice each calendar year, but at intervals not exceeding 7 1/2 months, inspect each mainline valve to determine that it is functioning properly. Each rupture-mitigation valve (RMV), as defined in § [195.2](#) and not contained in a gathering line, or alternative equivalent technology that is installed under § [195.258](#)(c) or § [195.418](#), must also be partially operated.

Operators are not required to close the valve fully during the inspection; a minimum 25 percent valve closure is sufficient to demonstrate compliance, unless the operator has operational information that requires an additional closure percentage for maintaining reliability.

- (c) Each operator shall provide protection for each valve from unauthorized operation and from vandalism.
- (d) For each remote-control valve (RCV) installed in accordance with § [195.258](#)(c) or § [195.418](#), an operator must conduct a point-to-point verification between SCADA system displays and the installed valves, sensors, and communications equipment, in accordance with § [195.446](#)(c) and (e).
- (e) For each alternative equivalent technology installed under § [195.258](#)(c) or (d) or § [195.418](#)(a) that is manually or locally operated (i.e., not an RMV, as that term is defined in § [195.2](#)):
 - (1) Operators must achieve a response time of 30 minutes or less, as required by § [195.419](#)(b), through an initial drill and through periodic validation as required by paragraph (e)(2) of this section. An operator must review each phase of the drill response and document the results to validate the total response time, including the identification of a rupture, and valve shut-off time as being less than or equal to 30 minutes after rupture identification.
 - (2) Within each pipeline system, and within each operating or maintenance field work unit, operators must randomly select an authorized rupture-mitigation alternative equivalent technology for an annual 30-minute-total response time validation drill simulating worst- case conditions for that location to ensure compliance with § [195.419](#). Operators are not required to close the alternative equivalent technology fully during the drill; a minimum 25 percent valve closure is sufficient to demonstrate compliance with the drill requirements unless the operator has operational information that requires an additional closure percentage for maintaining reliability. The response drill must occur at least once each calendar year, at intervals not to exceed 15 months. Operators must include in their written procedures the method they use to randomly select which alternative equivalent technology is tested in accordance with this paragraph.
 - (3) If the 30-minute-maximum response time cannot be achieved in the drill, the operator must revise response efforts to achieve compliance with § [195.419](#) no later than 12 months after the drill. Alternative valve shut-off measures must be in accordance with paragraph (f) of this section within 7 days of the drill.
 - (4) Based on the results of the response-time drills, the operator must include lessons learned in:
 - (i) Training and qualifications programs;
 - (ii) Design, construction, testing, maintenance, operating, and emergency procedures manuals; and
 - (iii) Any other areas identified by the operator as needing improvement.
- (f) Each operator must implement remedial measures as follows to correct any valve installed on an onshore pipeline in accordance with § [195.258](#)(c), or an RMV or alternative equivalent technology installed in accordance with § [195.418](#), that is indicated to be inoperable or unable to maintain effective shut-off:
 - (1) Repair or replace the valve as soon as practicable but no later than 12 months after finding that the valve is inoperable or unable to maintain shut-off. An operator may request an extension of the compliance deadline requirements of this section if it can demonstrate to PHMSA, in accordance with the notification procedures in § [195.18](#), that repairing or replacing a valve within 12 months would be economically, technically, or operationally infeasible; and

- (2) Designate an alternative compliant valve within 7 calendar days of the finding while repairs are being made and document an interim response plan to maintain safety. Alternative compliant valves are not required to comply with valve spacing requirements of this part.
- (g) An operator using an ASV as an RMV, in accordance with §§ [195.2](#), [195.260](#), [195.418](#), and [195.419](#), must document, in accordance with § [195.419](#)(f), and confirm the ASV shut-in pressures on a calendar year basis not to exceed 15 months. ASV shut-in set pressures must be proven and reset individually at each ASV, as required by § [195.419](#)(f), at least each calendar year, but at intervals not to exceed 15 months.
- (h) The requirements of paragraphs (d) through (g) of this section do not apply to gathering lines.

[Amdt. 195-22, 46 FR 38360, July 27, 1981; 47 FR 32721, July 29, 1982, as amended by Amdt. 195-24, 47 FR 46852, Oct. 21, 1982; Amdt. 195-105, 87 FR 20940, Apr. 8, 2022; Amdt. 195-106, 88 FR 50056, Aug. 1, 2023]

§195.422 Pipeline repairs.

- (a) Each operator shall, in repairing its pipeline systems, insure that the repairs are made in a safe manner and are made so as to prevent damage to persons or property.
- (b) No operator may use any pipe, valve, or fitting, for replacement in repairing pipeline facilities, unless it is designed and constructed as required by this part.

§195.424 Pipe movement.

- (a) No operator may move any line pipe, unless the pressure in the line section involved is reduced to not more than 50 percent of the maximum operating pressure.
- (b) No operator may move any pipeline containing highly volatile liquids where materials in the line section involved are joined by welding unless-
- (1) Movement when the pipeline does not contain highly volatile liquids is impractical;
 - (2) The procedures of the operator under §195.402 contain precautions to protect the public against the hazard in moving pipelines containing highly volatile liquids, including the use of warnings, where necessary, to evacuate the area close to the pipeline; and
 - (3) The pressure in that line section is reduced to the lower of the following:
 - (i) Fifty percent or less of the maximum operating pressure; or
 - (ii) The lowest practical level that will maintain the highly volatile liquid in a liquid state with continuous flow, but not less than 50 p.s.i. (345 kPa) gage above the vapor pressure of the commodity.
- (c) No operator may move any pipeline containing highly volatile liquids where materials in the line section involved are not joined by welding unless-
- (1) The operator complies with paragraphs [\(b\)\(1\)](#) and [\(2\)](#) of this section; and
 - (2) That line section is isolated to prevent the flow of highly volatile liquid.

[Amdt. 195-22, 46 FR 38360, July 27, 1981; 46 FR 38922, July 30, 1981, as amended by Amdt. 195-63, 63 FR 37506, July 13, 1998]

§195.426 Scraper and sphere facilities.

No operator may use a launcher or receiver that is not equipped with a relief device capable of safely relieving pressure in the barrel before insertion or removal of scrapers or spheres. The operator must use a suitable device to indicate that pressure has been relieved in the barrel or must provide a means to prevent insertion or removal of scrapers or spheres if pressure has not been relieved in the barrel.

[Amdt. 195-22, 46 FR 38360, July 27, 1981; 47 FR 32721, July 29, 1982]

§195.428 Overpressure safety devices and overflow protection systems.

This section has been amended by Amdt. 195-107, eff. 6/28/24.

- (a) Except as provided in paragraph (b) of this section, each operator shall, at intervals not exceeding 15 months, but at least once each calendar year, or in the case of pipelines used to carry highly volatile liquids, at intervals not to exceed 7½ months, but at least twice each calendar year, inspect and test each pressure limiting device, relief valve, pressure regulator, or other item of pressure control equipment to determine that it is functioning properly, is in good mechanical condition, and is adequate from the standpoint of capacity and reliability of operation for the service in which it is used.
- (b) In the case of relief valves on pressure breakout tanks containing highly volatile liquids, each operator shall test each valve at intervals not exceeding 5 years.
- (c) Aboveground breakout tanks that are constructed or significantly altered according to API Std 2510 (incorporated by reference, see [§195.3](#)) after October 2, 2000, must have an overflow protection system installed according to API Std 2510, section 7.1.2. Other aboveground breakout tanks with 600 gallons (2271 liters) or more of storage capacity that are constructed or significantly altered after October 2, 2000, must have an overflow protection system installed according to API Std 2350 (incorporated by reference, see [§195.3](#)). However, an operator need not comply with any part of API Std 2350 for a particular breakout tank if the operator describes in the manual required by [§195.402](#) why compliance with that part is not necessary for safety of the tank.
- (d) After October 2, 2000, the requirements of paragraphs (a) and (b) of this section for inspection and testing of pressure control equipment apply to the inspection and testing of overflow protection systems.

[34 FR 15473, Oct. 4, 1969 as amended by Amdt. 195-4, 37 FR 18733, Sept. 15, 1972; Amdt. 195-15, 44 FR 41197, July 16, 1979; Amdt. 195-22, 46 FR 38357, July 27, 1981; Amdt. 195-24, 47 FR 46850, Oct. 21, 1982; Amdt. 195-66, 64 FR 15926, Apr. 2, 1999; Amdt. 195-100, 80 FR 12762, Mar. 11, 2015; Amdt. 195-107, 89 FR 33264, Apr. 29, 2024]

§195.430 Firefighting equipment.

Each operator shall maintain adequate firefighting equipment at each pump station and breakout tank area. The equipment must be-

- (a) In proper operating condition at all times;
- (b) Plainly marked so that its identity as firefighting equipment is clear; and,
- (c) Located so that it is easily accessible during a fire.

§195.432 Inspection of in-service breakout tanks.

- (a) Except for breakout tanks inspected under paragraphs (b) and (c) of this section, each operator shall, at intervals not exceeding 15 months, but at least once each calendar year, inspect each in-service breakout tank.
- (b) Each operator must inspect the physical integrity of in-service atmospheric and low-pressure steel above-ground breakout tanks according to API Std 653 (except section 6.4.3, Alternative Internal Inspection Interval) (incorporated by reference, see §195.3). However, if structural conditions prevent access to the tank bottom, its integrity may be assessed according to a plan included in the operations and maintenance manual under §195.402(c)(3). The risk-based internal inspection procedures in API Std 653, section 6.4.3 cannot be used to determine the internal inspection interval.
 - (1) Operators who established internal inspection intervals based on risk-based inspection procedures prior to March 6, 2015 must re-establish internal inspection intervals based on API Std 653, section 6.4.2 (incorporated by reference, see §195.3).
 - (i) If the internal inspection interval was determined by the prior risk-based inspection procedure using API Std 653, section 6.4.3 and the resulting calculation exceeded 20 years, and it has been more than 20 years since an internal inspection was performed, the operator must complete a new internal inspection in accordance with § 195.432(b)(1) by January 5, 2017.
 - (ii) If the internal inspection interval was determined by the prior risk-based inspection procedure using API Std 653, section 6.4.3 and the resulting calculation was less than or equal to 20 years, and the time since the most recent internal inspection exceeds the re-established inspection interval in accordance with §195.432(b)(1), the operator must complete a new internal inspection by January 5, 2017.
 - (iii) If the internal inspection interval was not based upon current engineering and operational information (i.e., actual corrosion rate of floor plates, actual remaining thickness of the floor plates, etc.), the operator must complete a new internal inspection by January 5, 2017 and re-establish a new internal inspection interval in accordance with §195.432(b)(1).
 - (2) [Reserved]
- (c) Each operator must inspect the physical integrity of in-service steel aboveground breakout tanks built to API Std 2510 (incorporated by reference, see §195.3) according to section 6 of API Std 510 (incorporated by reference, see §195.3).
- (d) The intervals of inspection specified by documents referenced in paragraphs (b) and (c) of this section begin on May 3, 1999, or on the operator's last recorded date of the inspection, whichever is earlier.

[Amdt. 195-66, 64 FR 15936, Apr. 2, 1999, as amended by Amdt. 195-94, 75 FR 48607, Aug. 11, 2010, Amdt. 195-99, 80 FR 187, Jan. 5, 2015; 80 FR 46848, Aug. 6, 2015]

§195.434 Signs.

Each operator must maintain signs visible to the public around each pumping station and breakout tank area. Each sign must contain the name of the operator and a telephone number (including area code) where the operator can be reached at all times.

[Amdt. 195-78, 68 FR 53528, Sept. 11, 2003]4 FR 15473, Oct. 4, 1969 as amended by Amdt. 195-22, 46 FR 38357, July 27, 1981; Amdt. 195-78, 68 FR 53526, Sept. 11, 2003]

§195.436 Security of facilities.

Each operator shall provide protection for each pumping station and breakout tank area and other exposed facility (such as scraper traps) from vandalism and unauthorized entry.

§195.438 Smoking or open flames.

Each operator shall prohibit smoking and open flames in each pump station area and each breakout tank area where there is a possibility of the leakage of a flammable hazardous liquid or of the presence of flammable vapors.

§195.440 Public awareness.

- (a) Each pipeline operator must develop and implement a written continuing public education program that follows the guidance provided in the American Petroleum Institute's (API) Recommended Practice (RP) 1162 (incorporated by reference, see § [195.3](#)).
- (b) The operator's program must follow the general program recommendations of API RP 1162 and assess the unique attributes and characteristics of the operator's pipeline and facilities.
- (c) The operator must follow the general program recommendations, including baseline and supplemental requirements of API RP 1162, unless the operator provides justification in its program or procedural manual as to why compliance with all or certain provisions of the recommended practice is not practicable and not necessary for safety.
- (d) The operator's program must specifically include provisions to educate the public, appropriate government organizations, and persons engaged in excavation related activities on:
 - (1) Use of a one-call notification system prior to excavation and other damage prevention activities;
 - (2) Possible hazards associated with unintended releases from a hazardous liquid or carbon dioxide pipeline facility;
 - (3) Physical indications that such a release may have occurred;
 - (4) Steps that should be taken for public safety in the event of a hazardous liquid or carbon dioxide pipeline release; and
 - (5) Procedures to report such an event.
- (e) The program must include activities to advise affected municipalities, school districts, businesses, and residents of pipeline facility locations.
- (f) The program and the media used must be as comprehensive as necessary to reach all areas in which the operator transports hazardous liquid or carbon dioxide.
- (g) The program must be conducted in English and in other languages commonly understood by a significant number and concentration of the non-English speaking population in the operator's area.
- (h) Operators in existence on June 20, 2005, must have completed their written programs no later than June 20, 2006. Upon request, operators must submit their completed programs to PHMSA or, in the case of an intrastate pipeline facility operator, the appropriate State agency.
- (i) The operator's program documentation and evaluation results must be available for periodic review by appropriate regulatory agencies.

[Amdt. 195-84, 70 FR 28843, May 19, 2005]

§195.442 Damage prevention program.

- (a) Except as provided in [paragraph \(d\)](#) of this section, each operator of a buried pipeline must carry out, in accordance with this section, a written program to prevent damage to that pipeline from excavation activities. For the purpose of this section, the term "excavation activities" includes excavation, blasting, boring, tunneling, backfilling, the removal of aboveground structures by either explosive or mechanical means, and other earthmoving operations.
- (b) An operator may comply with any of the requirements of [paragraph \(c\)](#) of this section through participation in a public service program, such as a one-call system, but such participation does not relieve the operator of the responsibility for compliance with this section. However, an operator must perform the duties of [paragraph \(c\)\(3\)](#) of this section through participation in a one-call system, if that one-call system is a qualified one-call system. In areas that are covered by more than one qualified one-call system, an operator need only join one of the qualified one-call systems if there is a central telephone number for excavators to call for excavation activities, or if the one-call systems in those areas communicate with one another. An operator's pipeline system must be covered by a qualified one-call system where there is one in place. For the purpose of this section, a one-call system is considered a "qualified one-call system" if it meets the requirements of section (b)(1) or (b)(2) or this section.
- (1) The state has adopted a one-call damage prevention program under § 198.37 of this chapter; or
- (2) The one-call system:
- (i) Is operated in accordance with § 198.39 of this chapter;
 - (ii) Provides a pipeline operator an opportunity similar to a voluntary participant to have a part in management responsibilities; and
 - (iii) Assesses a participating pipeline operator a fee that is proportionate to the costs of the one-call system's coverage of the operator's pipeline.
- (c) The damage prevention program required by paragraph (a) of this section must, at a minimum:
- (1) Include the identity, on a current basis, of persons who normally engage in excavation activities in the area in which the pipeline is located.
 - (2) Provides for notification of the public in the vicinity of the pipeline and actual notification of persons identified in paragraph (c)(1) of this section of the following as often as needed to make them aware of the damage prevention program:
 - (i) The program's existence and purpose; and
 - (ii) How to learn the location of underground pipelines before excavation activities are begun.
 - (3) Provide a means of receiving and recording notification of planned excavation activities.
 - (4) If the operator has buried pipelines in the area of excavation activity, provide for actual notification of persons who give notice of their intent to excavate of the type of temporary marking to be provided and how to identify the markings.
 - (5) Provide for temporary marking of buried pipelines in the area of excavation activity before, as far as practical, the activity begins.
 - (6) Provide as follows for inspection of pipelines that an operator has reason to believe could be damaged by excavation activities:

- (i) The inspection must be done as frequently as necessary during and after the activities to verify the integrity of the pipeline; and
 - (ii) In the case of blasting, any inspection must include leakage surveys.
- (d) A damage prevention program under this section is not required for the following pipelines:
- (1) Pipelines located offshore.
 - (2) Pipelines to which access is physically controlled by the operator.

[Amdt. 195-54, 60 FR 14651, Mar. 20, 1995, as amended by Amdt. 195-60, 62 FR 61699, Nov. 19, 1997]

§195.444 Leak detection.

- (a) *Scope.* Except for offshore gathering and regulated rural gathering pipelines, this section applies to all hazardous liquid pipelines transporting liquid in single phase (without gas in the liquid).
- (b) *General.* A pipeline must have an effective system for detecting leaks in accordance with §§ [195.134](#) or 195.452, as appropriate. An operator must evaluate the capability of its leak detection system to protect the public, property, and the environment and modify it as necessary to do so. At a minimum, an operator's evaluation must consider the following factors - length and size of the pipeline, type of product carried, the swiftness of leak detection, location of nearest response personnel, and leak history.
- (c) *CPM leak detection systems.* Each computational pipeline monitoring (CPM) leak detection system installed on a hazardous liquid pipeline must comply with API RP 1130 (incorporated by reference, see § [195.3](#)) in operating, maintaining, testing, record keeping, and dispatcher training of the system.

[Amdt. 195-102, 84 FR 52296, Oct. 1, 2019]

§195.446 Control room management.

- (a) *General.* This section applies to each operator of a pipeline facility with a controller working in a control room who monitors and controls all or part of a pipeline facility through a SCADA system. Each operator must have and follow written control room management procedures that implement the requirements of this section. The procedures required by this section must be integrated, as appropriate, with the operator's written procedures required by § 195.402. An operator must develop the procedures no later than August 1, 2011, and must implement the procedures according to the following schedule. The procedures required by [paragraphs \(b\), \(c\)\(5\), \(d\)\(2\) and \(d\)\(3\), \(f\) and \(g\)](#) of this section must be implemented no later than October 1, 2011. The procedures required by [paragraphs \(c\)\(1\) through \(4\), \(d\)\(1\), \(d\)\(4\), and \(e\)](#) must be implemented no later than August 1, 2012. The training procedures required by paragraph (h) must be implemented no later than August 1, 2012, except that any training required by another paragraph of this section must be implemented no later than the deadline for that paragraph.
- (b) *Roles and responsibilities.* Each operator must define the roles and responsibilities of a controller during normal, abnormal, and emergency operating conditions. To provide for a controller's prompt and appropriate response to operating conditions, an operator must define each of the following:
 - (1) A controller's authority and responsibility to make decisions and take actions during normal operations;

- (2) A controller's role when an abnormal operating condition is detected, even if the controller is not the first to detect the condition, including the controller's responsibility to take specific actions and to communicate with others;
 - (3) A controller's role during an emergency, even if the controller is not the first to detect the emergency, including the controller's responsibility to take specific actions and to communicate with others;
 - (4) A method of recording controller shift-changes and any hand-over of responsibility between controllers; and
 - (5) The roles, responsibilities and qualifications of others who have the authority to direct or supersede the specific technical actions of controllers.
- (c) Provide adequate information. Each operator must provide its controllers with the information, tools, processes and procedures necessary for the controllers to carry out the roles and responsibilities the operator has defined by performing each of the following:
- (1) Implement API RP 1165 (incorporated by reference, see §195.3) whenever a SCADA system is added, expanded or replaced, unless the operator demonstrates that certain provisions of API RP 1165 are not practical for the SCADA system used;
 - (2) Conduct a point-to-point verification between SCADA displays and related field equipment when field equipment is added or moved and when other changes that affect pipeline safety are made to field equipment or SCADA displays;
 - (3) Test and verify an internal communication plan to provide adequate means for manual operation of the pipeline safely, at least once each calendar year, but at intervals not to exceed 15 months;
 - (4) Test any backup SCADA systems at least once each calendar year, but at intervals not to exceed 15 months; and
 - (5) Implement section 5 of API RP 1168 (incorporated by reference, see § 195.3) to establish procedures for when a different controller assumes responsibility, including the content of information to be exchanged.
- (d) Fatigue mitigation. Each operator must implement the following methods to reduce the risk associated with controller fatigue that could inhibit a controller's ability to carry out the roles and responsibilities the operator has defined:
- (1) Establish shift lengths and schedule rotations that provide controllers off-duty time sufficient to achieve eight hours of continuous sleep;
 - (2) Educate controllers and supervisors in fatigue mitigation strategies and how off-duty activities contribute to fatigue;
 - (3) Train controllers and supervisors to recognize the effects of fatigue; and
 - (4) Establish a maximum limit on controller hours-of-service, which may provide for an emergency deviation from the maximum limit if necessary for the safe operation of a pipeline facility.
- (e) Alarm management. Each operator using a SCADA system must have a written alarm management plan to provide for effective controller response to alarms. An operator's plan must include provisions to:
- (1) Review SCADA safety-related alarm operations using a process that ensures alarms are accurate and support safe pipeline operations;
 - (2) Identify at least once each calendar month points affecting safety that have been taken off scan in the SCADA host, have had alarms inhibited, generated false alarms, or that have had forced or

- manual values for periods of time exceeding that required for associated maintenance or operating activities;
- (3) Verify the correct safety-related alarm set-point values and alarm descriptions when associated field instruments are calibrated or changed and at least once each calendar year, but at intervals not to exceed 15 months;
 - (4) Review the alarm management plan required by this paragraph at least once each calendar year, but at intervals not exceeding 15 months, to determine the effectiveness of the plan;
 - (5) Monitor the content and volume of general activity being directed to and required of each controller at least once each calendar year, but at intervals not exceeding 15 months, that will assure controllers have sufficient time to analyze and react to incoming alarms; and
 - (6) Address deficiencies identified through the implementation of paragraphs [\(e\)\(1\)](#) through [\(e\)\(5\)](#) of this section.
- (f) Change management. Each operator must assure that changes that could affect control room operations are coordinated with the control room personnel by performing each of the following:
- (1) Implement section 7 of API RP 1168 (incorporated by reference, see § [195.3](#)) for control room management change and require coordination between control room representatives, operator's management, and associated field personnel when planning and implementing physical changes to pipeline equipment or configuration; and
 - (2) Require its field personnel to contact the control room when emergency conditions exist and when making field changes that affect control room operations.
- (g) Operating experience. Each operator must assure that lessons learned from its operating experience are incorporated, as appropriate, into its control room management procedures by performing each of the following:
- (1) Review accidents that must be reported pursuant to § [195.50](#) and [195.52](#) to determine if control room actions contributed to the event and, if so, correct, where necessary, deficiencies related to:
 - (i) Controller fatigue;
 - (ii) Field equipment;
 - (iii) The operation of any relief device;
 - (iv) Procedures;
 - (v) SCADA system configuration; and
 - (vi) SCADA system performance.
 - (2) Include lessons learned from the operator's experience in the training program required by this section.
- (h) Training. Each operator must establish a controller training program and review the training program content to identify potential improvements at least once each calendar year, but at intervals not to exceed 15 months. An operator's program must provide for training each controller to carry out the roles and responsibilities defined by the operator. In addition, the training program must include the following elements:
- (1) Responding to abnormal operating conditions likely to occur simultaneously or in sequence;
 - (2) Use of a computerized simulator or non-computerized (tabletop) method for training controllers to recognize abnormal operating conditions;
 - (3) Training controllers on their responsibilities for communication under the operator's emergency response procedures;

- (4) Training that will provide a controller a working knowledge of the pipeline system, especially during the development of abnormal operating conditions;
 - (5) For pipeline operating setups that are periodically, but infrequently used, providing an opportunity for controllers to review relevant procedures in advance of their application; and
 - (6) Control room team training and exercises that include both controllers and other individuals, defined by the operator, who would reasonably be expected to operationally collaborate with controllers (control room personnel) during normal, abnormal or emergency situations. Operators must comply with the team training requirements under this paragraph no later than January 23, 2018.
- (i) Compliance validation. Upon request, operators must submit their procedures to PHMSA or, in the case of an intrastate pipeline facility regulated by a State, to the appropriate State agency.
- (j) Compliance and deviations. An operator must maintain for review during inspection:
- (1) Records that demonstrate compliance with the requirements of this section; and
 - (2) Documentation to demonstrate that any deviation from the procedures required by this section was necessary for the safe operation of the pipeline facility.

[Amdt. 195-93, 74 FR 63329, Dec. 3, 2009, as amended at 75 FR 5537, Feb. 3, 2010; 76 FR 35135, June 16, 2011; Amdt. 195-101, 82 FR 7999, Jan. 23, 2017]

§195.450 Definitions.

The following definitions apply to this section and §195.452:

Emergency flow restricting device or EFRD means a check valve or remote control valve as follows:

- (1) Check valve means a valve that permits fluid to flow freely in one direction and contains a mechanism to automatically prevent flow in the other direction.
- (2) Remote control valve or RCV means any valve that is operated from a location remote from where the valve is installed. The RCV is usually operated by the supervisory control and data acquisition (SCADA) system. The linkage between the pipeline control center and the RCV may be by fiber optics, microwave, telephone lines, or satellite.

High consequence area means:

- (1) A commercially navigable waterway, which means a waterway where a substantial likelihood of commercial navigation exists;
- (2) A high population area, which means an urbanized area, as defined and delineated by the Census Bureau, that contains 50,000 or more people and has a population density of at least 1,000 people per square mile;
- (3) An other populated area, which means a place, as defined and delineated by the Census Bureau, that contains a concentrated population, such as an incorporated or unincorporated city, town, village, or other designated residential or commercial area;
- (4) An unusually sensitive area, as defined in [§195.6](#).

[Amdt. 195-70, 65 FR 75405, Dec. 1, 2000]

§195.452 Pipeline integrity management in high consequence areas.

(a) *Which pipelines are covered by this section?* This section applies to each hazardous liquid pipeline and carbon dioxide pipeline that could affect a high consequence area, including any pipeline located in a high consequence area unless the operator effectively demonstrates by risk assessment that the pipeline could not affect the area. ([Appendix C](#) of this part provides guidance on determining if a pipeline could affect a high consequence area.) Covered pipelines are categorized as follows:

- (1) Category 1 includes pipelines existing on May 29, 2001, that were owned or operated by an operator who owned or operated a total of 500 or more miles of pipeline subject to this part.
- (2) Category 2 includes pipelines existing on May 29, 2001, that were owned or operated by an operator who owned or operated less than 500 miles of pipeline subject to this part.
- (3) Category 3 includes pipelines constructed or converted after May 29, 2001, and low-stress pipelines in rural areas under § [195.12](#).
- (4) Low stress pipelines as specified in § [195.12](#).

(b) *What program and practices must operators use to manage pipeline integrity?* Each operator of a pipeline covered by this section must:

- (1) Develop a written integrity management program that addresses the risks on each segment of pipeline in the first column of the following table no later than the date in the second column:

Pipeline	Date
Category 1	March 31, 2002.
Category 2	February 18, 2003.
Category 3	Date the pipeline begins operation or as provided in § 195.12 for low stress pipelines in rural areas.

- (2) Include in the program an identification of each pipeline or pipeline segment in the first column of the following table not later than the date in the second column:

Pipeline	Date
Category 1	December 31, 2001.
Category 2	November 18, 2002.
Category 3	Date the pipeline begins operation.

- (3) Include in the program a plan to carry out baseline assessments of line pipe as required by [paragraph \(c\)](#) of this section.
- (4) Include in the program a framework that-
 - (i) Addresses each element of the integrity management program under [paragraph \(f\)](#) of this section, including continual integrity assessment and evaluation under [paragraph \(j\)](#) of this section; and
 - (ii) Initially indicates how decisions will be made to implement each element.
- (5) Implement and follow the program.
- (6) Follow recognized industry practices in carrying out this section, unless-

- (i) This section specifies otherwise; or
- (ii) The operator demonstrates that an alternative practice is supported by a reliable engineering evaluation and provides an equivalent level of public safety and environmental protection.

(c) *What must be in the baseline assessment plan?*

(1) An operator must include each of the following elements in its written baseline assessment plan:

- (i) The methods selected to assess the integrity of the line pipe. An operator must assess the integrity of the line pipe by in-line inspection tool(s) described in paragraph [\(c\)\(1\)\(i\)\(A\)](#) of this section for the range of relevant threats to the pipeline segment. If it is impracticable based upon the construction of the pipeline (e.g., diameter changes, sharp bends, and elbows) or operational limits including operating pressure, low flow, pipeline length, or availability of in-line inspection tool technology for the pipe diameter, then the operator must use the appropriate method(s) in paragraphs [\(c\)\(1\)\(i\)\(B\)](#), [\(C\)](#), or [\(D\)](#) of this section for the range of relevant threats to the pipeline segment. The methods an operator selects to assess low-frequency electric resistance welded pipe, pipe with a seam factor less than 1.0 as defined in § [195.106](#)(e) or lap-welded pipe susceptible to longitudinal seam failure, must be capable of assessing seam integrity, cracking, and of detecting corrosion and deformation anomalies.

(A) In-line inspection tool or tools capable of detecting corrosion and deformation anomalies including dents, gouges, and grooves. For pipeline segments with an identified or probable risk or threat related to cracks (such as at pipe body or weld seams) based on the risk factors specified in [paragraph \(e\)](#), an operator must use an in-line inspection tool or tools capable of detecting crack anomalies. When performing an assessment using an in-line inspection tool, an operator must comply with § [195.591](#). An operator using this method must explicitly consider uncertainties in reported results (including tool tolerance, anomaly findings, and unity chart plots or equivalent for determining uncertainties) in identifying anomalies;

(B) Pressure test conducted in accordance with [subpart E](#) of this part;

(C) External corrosion direct assessment in accordance with § [195.588](#); or

(D) Other technology that the operator demonstrates can provide an equivalent understanding of the condition of the line pipe. An operator choosing this option must notify the Office of Pipeline Safety (OPS) 90 days before conducting the assessment, by sending a notice to the address or facsimile number specified in [paragraph \(m\)](#) of this section.

(ii) A schedule for completing the integrity assessment;

(iii) An explanation of the assessment methods selected and evaluation of risk factors considered in establishing the assessment schedule.

(2) An operator must document, prior to implementing any changes to the plan, any modification to the plan, and reasons for the modification.

(d) *When must operators complete baseline assessments?*

- (1) *All pipelines.* An operator must complete the baseline assessment before a new or conversion-to-service pipeline begins operation through the development of procedures, identification of high consequence areas, and pressure testing of could-affect high consequence areas in accordance with § [195.304](#).

- (2) *Newly identified areas.* If an operator obtains information (whether from the information analysis required under [paragraph \(g\)](#) of this section, Census Bureau maps, or any other source) demonstrating that the area around a pipeline segment has changed to meet the definition of a high consequence area (see § [195.450](#)), that area must be incorporated into the operator's baseline assessment plan within 1 year from the date that the information is obtained. An operator must complete the baseline assessment of any pipeline segment that could affect a newly identified high consequence area within 5 years from the date an operator identifies the area.
- (e) *What are the risk factors for establishing an assessment schedule (for both the baseline and continual integrity assessments)?*
- (1) An operator must establish an integrity assessment schedule that prioritizes pipeline segments for assessment (see [paragraphs \(d\)\(1\)](#) and [\(j\)\(3\)](#) of this section). An operator must base the assessment schedule on all risk factors that reflect the risk conditions on the pipeline segment. The factors an operator must consider include, but are not limited to:
- (i) Results of the previous integrity assessment, defect type and size that the assessment method can detect, and defect growth rate;
 - (ii) Pipe size, material, manufacturing information, coating type and condition, and seam type;
 - (iii) Leak history, repair history and cathodic protection history;
 - (iv) Product transported;
 - (v) Operating stress level;
 - (vi) Existing or projected activities in the area;
 - (vii) Local environmental factors that could affect the pipeline (e.g., seismicity, corrosivity of soil, subsidence, climatic);
 - (viii) geo-technical hazards; and
 - (ix) Physical support of the segment such as by a cable suspension bridge.
- (2) [Appendix C](#) of this part provides further guidance on risk factors.
- (f) *What are the elements of an integrity management program?* An integrity management program begins with the initial framework. An operator must continually change the program to reflect operating experience, conclusions drawn from results of the integrity assessments, and other maintenance and surveillance data, and evaluation of consequences of a failure on the high consequence area. An operator must include, at minimum, each of the following elements in its written integrity management program:
- (1) A process for identifying which pipeline segments could affect a high consequence area;
 - (2) A baseline assessment plan meeting the requirements of [paragraph \(c\)](#) of this section;
 - (3) An analysis that integrates all available information about the integrity of the entire pipeline and the consequences of a failure (see [paragraph \(g\)](#) of this section);
 - (4) Criteria for remedial actions to address integrity issues raised by the assessment methods and information analysis (see [paragraph \(h\)](#) of this section);
 - (5) A continual process of assessment and evaluation to maintain a pipeline's integrity (see [paragraph \(j\)](#) of this section);
 - (6) Identification of preventive and mitigative measures to protect the high consequence area (see [paragraph \(i\)](#) of this section);
 - (7) Methods to measure the program's effectiveness (see [paragraph \(k\)](#) of this section);
 - (8) A process for review of integrity assessment results and information analysis by a person qualified to evaluate the results and information (see [paragraph \(h\)\(2\)](#) of this section).

(g) *What is an information analysis?* In periodically evaluating the integrity of each pipeline segment (see [paragraph \(j\)](#) of this section), an operator must analyze all available information about the integrity of its entire pipeline and the consequences of a possible failure along the pipeline. Operators must continue to comply with the data integration elements specified in § 195.452(g) that were in effect on October 1, 2018, until October 1, 2022. Operators must begin to integrate all the data elements specified in this section starting October 1, 2020, with all attributes integrated by October 1, 2022. This analysis must:

- (1) Integrate information and attributes about the pipeline that include, but are not limited to:
 - (i) Pipe diameter, wall thickness, grade, and seam type;
 - (ii) Pipe coating, including girth weld coating;
 - (iii) Maximum operating pressure (MOP) and temperature;
 - (iv) Endpoints of segments that could affect high consequence areas (HCAs);
 - (v) Hydrostatic test pressure including any test failures or leaks - if known;
 - (vi) Location of casings and if shorted;
 - (vii) Any in-service ruptures or leaks - including identified causes;
 - (viii) Data gathered through integrity assessments required under this section;
 - (ix) Close interval survey (CIS) survey results;
 - (x) Depth of cover surveys;
 - (xi) Corrosion protection (CP) rectifier readings;
 - (xii) CP test point survey readings and locations;
 - (xiii) AC/DC and foreign structure interference surveys;
 - (xiv) Pipe coating surveys and cathodic protection surveys.
 - (xv) Results of examinations of exposed portions of buried pipelines (i.e., pipe and pipe coating condition, see § [195.569](#));
 - (xvi) Stress corrosion cracking (SCC) and other cracking (pipe body or weld) excavations and findings, including in- situ non-destructive examinations and analysis results for failure stress pressures and cyclic fatigue crack growth analysis to estimate the remaining life of the pipeline;
 - (xvii) Aerial photography;
 - (xviii) Location of foreign line crossings;
 - (xix) Pipe exposures resulting from repairs and encroachments;
 - (xx) Seismicity of the area; and
 - (xxi) Other pertinent information derived from operations and maintenance activities and any additional tests, inspections, surveys, patrols, or monitoring required under this part.
- (2) Consider information critical to determining the potential for, and preventing, damage due to excavation, including current and planned damage prevention activities, and development or planned development along the pipeline;
- (3) Consider how a potential failure would affect high consequence areas, such as location of a water intake.
- (4) Identify spatial relationships among anomalous information (e.g., corrosion coincident with foreign line crossings; evidence of pipeline damage where aerial photography shows evidence of encroachment). Storing the information in a geographic information system (GIS), alone, is not sufficient. An operator must analyze for interrelationships among the data.

(h) *What actions must an operator take to address integrity issues?*

- (1) *General requirements.* An operator must take prompt action to address all anomalous conditions in the pipeline that the operator discovers through the integrity assessment or information

analysis. In addressing all conditions, an operator must evaluate all anomalous conditions and remediate those that could reduce a pipeline's integrity, as required by this part. An operator must be able to demonstrate that the remediation of the condition will ensure that the condition is unlikely to pose a threat to the long-term integrity of the pipeline. An operator must comply with all other applicable requirements in this part in remediating a condition. Each operator must, in repairing its pipeline systems, ensure that the repairs are made in a safe and timely manner and are made so as to prevent damage to persons, property, or the environment. The calculation method(s) used for anomaly evaluation must be applicable for the range of relevant threats.

- (i) *Temporary pressure reduction.* An operator must notify PHMSA, in accordance with [paragraph \(m\)](#) of this section, if the operator cannot meet the schedule for evaluation and remediation required under paragraph [\(h\)\(3\)](#) of this section and cannot provide safety through a temporary reduction in operating pressure.
 - (ii) *Long-term pressure reduction.* When a pressure reduction exceeds 365 days, the operator must notify PHMSA in accordance with paragraph (m) of this section and explain the reasons for the delay. An operator must also take further remedial action to ensure the safety of the pipeline.
- (2) *Discovery of condition.* Discovery of a condition occurs when an operator has adequate information to determine that a condition presenting a potential threat to the integrity of the pipeline exists. An operator must promptly, but no later than 180 days after an assessment, obtain sufficient information about a condition to make that determination, unless the operator can demonstrate the 180-day interval is impracticable. If the operator believes that 180 days are impracticable to make a determination about a condition found during an assessment, the pipeline operator must notify PHMSA in accordance with [paragraph \(m\)](#) of this section and provide an expected date when adequate information will become available.
- (3) *Schedule for evaluation and remediation.* An operator must complete remediation of a condition according to a schedule prioritizing the conditions for evaluation and remediation. If an operator cannot meet the schedule for any condition, the operator must explain the reasons why it cannot meet the schedule and how the changed schedule will not jeopardize public safety or environmental protection.
- (4) *Special requirements for scheduling remediation*
 - (i) Immediate repair conditions. An operator's evaluation and remediation schedule must provide for immediate repair conditions. To maintain safety, an operator must temporarily reduce the operating pressure or shut down the pipeline until the operator completes the repair of these conditions. An operator must calculate the temporary reduction in operating pressure using the formulas referenced in paragraph [\(h\)\(4\)\(i\)\(B\)](#) of this section. If no suitable remaining strength calculation method can be identified, an operator must implement a minimum 20 percent or greater operating pressure reduction, based on actual operating pressure for two months prior to the date of inspection, until the anomaly is repaired. An operator must treat the following conditions as immediate repair conditions:
 - (A) Metal loss greater than 80% of nominal wall regardless of dimensions.
 - (B) A calculation of the remaining strength of the pipe shows a predicted burst pressure less than the established maximum operating pressure at the location of the anomaly. Suitable remaining strength calculation methods include, but are not limited to, ASME/ANSI B31G (incorporated by reference, see [§195.3](#)) and PRCI PR-3-805 (R-STRENG) (incorporated by reference, see [§195.3](#)).

- (C) A dent located on the top of the pipeline (above the 4 and 8 o'clock positions) that has any indication of metal loss, cracking or a stress riser.
 - (D) A dent located on the top of the pipeline (above the 4 and 8 o'clock positions) with a depth greater than 6% of the nominal pipe diameter.
 - (E) An anomaly that in the judgment of the person designated by the operator to evaluate the assessment results requires immediate action.
- (ii) 60-day conditions. Except for conditions listed in paragraph [\(h\)\(4\)\(i\)](#) of this section, an operator must schedule evaluation and remediation of the following conditions within 60 days of discovery of condition.
- (A) A dent located on the top of the pipeline (above the 4 and 8 o'clock positions) with a depth greater than 3% of the pipeline diameter (greater than 0.250 inches in depth for a pipeline diameter less than Nominal Pipe Size (NPS) 12).
 - (B) A dent located on the bottom of the pipeline that has any indication of metal loss, cracking or a stress riser.
- (iii) 180-day conditions. Except for conditions listed in paragraph [\(h\)\(4\)\(i\)](#) or [\(ii\)](#) of this section, an operator must schedule evaluation and remediation of the following within 180 days of discovery of the condition:
- (A) A dent with a depth greater than 2% of the pipeline's diameter (0.250 inches in depth for a pipeline diameter less than NPS 12) that affects pipe curvature at a girth weld or a longitudinal seam weld.
 - (B) A dent located on the top of the pipeline (above 4 and 8 o'clock position) with a depth greater than 2% of the pipeline's diameter (0.250 inches in depth for a pipeline diameter less than NPS 12).
 - (C) A dent located on the bottom of the pipeline with a depth greater than 6% of the pipeline's diameter.
 - (D) A calculation of the remaining strength of the pipe shows an operating pressure that is less than the current established maximum operating pressure at the location of the anomaly. Suitable remaining strength calculation methods include, but are not limited to, ASME/ANSI B31G and PRCI PR-3-805 (R-STRENG).
 - (E) An area of general corrosion with a predicted metal loss greater than 50% of nominal wall.
 - (F) Predicted metal loss greater than 50% of nominal wall that is located at a crossing of another pipeline, or is in an area with widespread circumferential corrosion, or is in an area that could affect a girth weld.
 - (G) A potential crack indication that when excavated is determined to be a crack.
 - (H) Corrosion of or along a longitudinal seam weld.
 - (I) A gouge or groove greater than 12.5% of nominal wall.
- (iv) Other conditions. In addition to the conditions listed in paragraphs [\(h\)\(4\)\(i\)](#) through [\(iii\)](#) of this section, an operator must evaluate any condition identified by an integrity assessment or information analysis that could impair the integrity of the pipeline, and as appropriate, schedule the condition for remediation. [Appendix C](#) of this part contains guidance concerning other conditions that an operator should evaluate.
- (i) *What preventive and mitigative measures must an operator take to protect the high consequence area?*

- (1) *General requirements.* An operator must take measures to prevent and mitigate the consequences of a pipeline failure that could affect a high consequence area. These measures include conducting a risk analysis of the pipeline segment to identify additional actions to enhance public safety or environmental protection. Such actions may include, but are not limited to, implementing damage prevention best practices, better monitoring of cathodic protection where corrosion is a concern, establishing shorter inspection intervals, installing EFRDs on the pipeline segment, modifying the systems that monitor pressure and detect leaks, providing additional training to personnel on response procedures, conducting drills with local emergency responders and adopting other management controls.
- (2) *Risk analysis criteria.* In identifying the need for additional preventive and mitigative measures, an operator must evaluate the likelihood of a pipeline release occurring and how a release could affect the high consequence area. This determination must consider all relevant risk factors, including, but not limited to:
 - (i) Terrain surrounding the pipeline segment, including drainage systems such as small streams and other smaller waterways that could act as a conduit to the high consequence area;
 - (ii) Elevation profile;
 - (iii) Characteristics of the product transported;
 - (iv) Amount of product that could be released;
 - (v) Possibility of a spillage in a farm field following the drain tile into a waterway;
 - (vi) Ditches along side a roadway the pipeline crosses;
 - (vii) Physical support of the pipeline segment such as by a cable suspension bridge;
 - (viii) Exposure of the pipeline to operating pressure exceeding established maximum operating pressure;
 - (ix) Seismicity of the area.
- (3) *Leak detection.* An operator must have a means to detect leaks on its pipeline system. An operator must evaluate the capability of its leak detection means and modify, as necessary, to protect the high consequence area. An operator's evaluation must, at least, consider, the following factors - length and size of the pipeline, type of product carried, the pipeline's proximity to the high consequence area, the swiftness of leak detection, location of nearest response personnel, leak history, and risk assessment results.
- (4) *Emergency Flow Restricting Devices (EFRD).* If an operator determines that an EFRD is needed on a pipeline segment that is located in, or which could affect, a high-consequence area (HCA) in the event of a hazardous liquid an operator must install the EFRD. In making this determination, an operator must, at least, evaluate the following factors--the swiftness of leak detection and pipeline shutdown capabilities, the type of commodity carried, the rate of potential leakage, the volume that can be released, topography or pipeline profile, the potential for ignition, proximity to power sources, location of nearest response personnel, specific terrain within the HCA or between the pipeline segment and the HCA it could affect, and benefits expected by reducing the spill size. An RMV installed under this paragraph must meet all of the other applicable requirements in this part.
 - (i) Where EFRDs are installed on pipeline segments in HCAs and that could affect HCAs with diameters of 6 inches or greater and that are placed into service or that have had 2 or more miles of pipe replaced within 5 contiguous miles within a 24-month period after April 10, 2023, the location, installation, actuation, operation, and maintenance of such EFRDs (including valve actuators, personnel response, operational control centers, supervisory control and data acquisition (SCADA), communications, and procedures) must meet the

design, operation, testing, maintenance, and rupture-mitigation requirements of §§ [195.258](#), [195.260](#), [195.402](#), [195.418](#), [195.419](#), and [195.420](#).

- (ii) The EFRD analysis and assessments specified in this paragraph (i)(4) must be completed prior to placing into service all onshore pipelines with diameters of 6 inches or greater and that are constructed or that have had 2 or more miles of pipe within any 5 contiguous miles within any 24-month period replaced after April 10, 2023. Implementation of EFRD findings for RMVs must meet § [195.418](#).
 - (iii) An operator may request an exemption from the compliance deadline requirements of this section if it can demonstrate to PHMSA, in accordance with the notification procedures in § [195.18](#), that installing an EFRD by that compliance deadline would be economically, technically, or operationally infeasible.
- (j) *What is a continual process of evaluation and assessment to maintain a pipeline's integrity?*
- (1) *General.* After completing the baseline integrity assessment, an operator must continue to assess the line pipe at specified intervals and periodically evaluate the integrity of each pipeline segment that could affect a high consequence area.
 - (2) *Verifying covered segments.* An operator must verify the risk factors used in identifying pipeline segments that could affect a high consequence area on at least an annual basis not to exceed 15 months ([Appendix C](#) of this part provides additional guidance on factors that can influence whether a pipeline segment could affect a high consequence area). If a change in circumstance indicates that the prior consideration of a risk factor is no longer valid or that an operator should consider new risk factors, an operator must perform a new integrity analysis and evaluation to establish the endpoints of any previously identified covered segments. The integrity analysis and evaluation must include consideration of the results of any baseline and periodic integrity assessments (see [paragraphs \(b\), \(c\), \(d\), and \(e\)](#) of this section), information analyses (see [paragraph \(g\)](#) of this section), and decisions about remediation and preventive and mitigative actions (see [paragraphs \(h\) and \(i\)](#) of this section). An operator must complete the first annual verification under this paragraph no later than July 1, 2021.
 - (3) *Assessment intervals.* An operator must establish five-year intervals, not to exceed 68 months, for continually assessing the line pipe's integrity. An operator must base the assessment intervals on the risk the line pipe poses to the high consequence area to determine the priority for assessing the pipeline segments. An operator must establish the assessment intervals based on the factors specified in [paragraph \(e\)](#) of this section, the analysis of the results from the last integrity assessment, and the information analysis required by [paragraph \(g\)](#) of this section.
 - (4) *Variance from the 5-year intervals in limited situations-*
 - (i) *Engineering basis.* An operator may be able to justify an engineering basis for a longer assessment interval on a segment of line pipe. The justification must be supported by a reliable engineering evaluation combined with the use of other technology, such as external monitoring technology, that provides an understanding of the condition of the line pipe equivalent to that which can be obtained from the assessment methods allowed in [paragraph \(j\)\(5\)](#) of this section. An operator must notify OPS 270 days before the end of the five-year (or less) interval of the justification for a longer interval, and propose an alternative interval. An operator must send the notice to the address specified in [paragraph \(m\)](#) of this section.
 - (ii) *Unavailable technology.* An operator may require a longer assessment period for a segment of line pipe (for example, because sophisticated internal inspection technology is not available). An operator must justify the reasons why it cannot comply with the required

assessment period and must also demonstrate the actions it is taking to evaluate the integrity of the pipeline segment in the interim. An operator must notify OPS 180 days before the end of the five-year (or less) interval that the operator may require a longer assessment interval, and provide an estimate of when the assessment can be completed. An operator must send a notice to the address specified in [paragraph \(m\)](#) of this section.

- (5) *Assessment methods.* An operator must assess the integrity of the line pipe by any of the following methods. The methods an operator selects to assess low frequency electric resistance welded pipe or lap welded pipe susceptible to longitudinal seam failure must be capable of assessing seam integrity and of detecting corrosion and deformation anomalies.
- (i) In-Line Inspection tool or tools capable of detecting corrosion and deformation anomalies, including dents, gouges, and grooves. For pipeline segments that are susceptible to cracks (pipe body and weld seams), an operator must use an in-line inspection tool or tools capable of detecting crack anomalies. When performing an assessment using an In-Line Inspection tool, an operator must comply with § [195.591](#);
 - (ii) Pressure test conducted in accordance with [subpart E](#) of this part;
 - (iii) External corrosion direct assessment in accordance with § [195.588](#); or
 - (iv) Other technology that the operator demonstrates can provide an equivalent understanding of the condition of the line pipe. An operator choosing this option must notify OPS 90 days before conducting the assessment, by sending a notice to the address or facsimile number specified in [paragraph \(m\)](#) of this section.
- (k) *What methods to measure program effectiveness must be used?* An operator's program must include methods to measure whether the program is effective in assessing and evaluating the integrity of each pipeline segment and in protecting the high consequence areas. See [Appendix C](#) of this part for guidance on methods that can be used to evaluate a program's effectiveness.
- (l) *What records must an operator keep to demonstrate compliance?*
- (1) An operator must maintain, for the useful life of the pipeline, records that demonstrate compliance with the requirements of this subpart. At a minimum, an operator must maintain the following records for review during an inspection:
 - (i) A written integrity management program in accordance with [paragraph \(b\)](#) of this section.
 - (ii) Documents to support the decisions and analyses, including any modifications, justifications, deviations and determinations made, variances, and actions taken, to implement and evaluate each element of the integrity management program listed in [paragraph \(f\)](#) of this section.
 - (2) See [Appendix C](#) of this part for examples of records an operator would be required to keep.
- (m) *How does an operator notify PHMSA?* An operator must provide any notification required by this section by:
- (1) Sending the notification by electronic mail to InformationResourcesManager@dot.gov; or
 - (2) Sending the notification by mail to ATTN: Information Resources Manager, DOT/PHMSA/OPS, East Building, 2nd Floor, E22-321, 1200 New Jersey Ave SE., Washington, DC 20590.
- (n) *Accommodation of instrumented internal inspection devices -*
- (1) *Scope.* This paragraph does not apply to any pipeline facilities listed in § [195.120](#)(b).
 - (2) *General.* An operator must ensure that each pipeline is modified to accommodate the passage of an instrumented internal inspection device by July 2, 2040.

- (3) *Newly identified areas.* If a pipeline could affect a newly identified high consequence area (see [paragraph \(d\)\(2\)](#) of this section) after July 2, 2035, an operator must modify the pipeline to accommodate the passage of an instrumented internal inspection device within 5 years of the date of identification or before performing the baseline assessment, whichever is sooner.
- (4) *Lack of accommodation.* An operator may file a petition under § 190.9 of this chapter for a finding that the basic construction (i.e., length, diameter, operating pressure, or location) of a pipeline cannot be modified to accommodate the passage of an instrumented internal inspection device or that the operator determines it would abandon or shut-down a pipeline as a result of the cost to comply with the requirement of this section.
- (5) *Emergencies.* An operator may file a petition under § 190.9 of this chapter for a finding that a pipeline cannot be modified to accommodate the passage of an instrumented internal inspection device as a result of an emergency. An operator must file such a petition within 30 days after discovering the emergency. If the petition is denied, the operator must modify the pipeline to allow the passage of an instrumented internal inspection device within 1 year after the date of the notice of the denial.

[Amdt. 195-70, 65 FR 75406, Dec. 1, 2000; Amdt 195-105, 87 FR 20940, Apr. 8, 2022]

§195.454 Integrity assessments for certain underwater hazardous liquid pipeline facilities located in high consequence areas.

Notwithstanding any pipeline integrity management program or integrity assessment schedule otherwise required under §195.452, each operator of any underwater hazardous liquid pipeline facility located in a high consequence area that is not an offshore pipeline facility and any portion of which is located at depths greater than 150 feet under the surface of the water must ensure that:

- (a) Pipeline integrity assessments using internal inspection technology appropriate for the integrity threats to the pipeline are completed not less often than once every 12 months, and;
- (b) Pipeline integrity assessments using pipeline route surveys, depth of cover surveys, pressure tests, external corrosion direct assessment, or other technology that the operator demonstrates can further the understanding of the condition of the pipeline facility, are completed on a schedule based on the risk that the pipeline facility poses to the high consequence area in which the pipeline facility is located.

[Amdt. 195-102, 84 FR 52298, Oct. 1, 2019]

Subpart G - Qualification of Pipeline Personnel (§§501-509)

Subpart G - Qualification of Pipeline Personnel

- 195.501 [Scope.](#)
- 195.503 [Definitions](#)
- 195.505 [Qualification Program](#)
- 195.507 [Recordkeeping](#)
- 195.509 [General](#)

§195.501 Scope.

- (a) This subpart prescribes the minimum requirements for operator qualification of individuals performing covered tasks on a pipeline facility.
- (b) For the purpose of this subpart, a covered task is an activity, identified by the operator, that:
 - (1) Is performed on a pipeline facility;
 - (2) Is an operations or maintenance task;
 - (3) Is performed as a requirement of this part; and
 - (4) Affects the operation or integrity of the pipeline.

§195.503 Definitions.

Abnormal operating condition means a condition identified by the operator that may indicate a malfunction of a component or deviation from normal operations that may:

- (a) Indicate a condition exceeding design limits; or
- (b) Result in a hazard(s) to persons, property, or the environment.

Evaluation means a process, established and documented by the operator, to determine an individual's ability to perform a covered task by any of the following:

- (a) Written examination;
- (b) Oral examination;
- (c) Work performance history review;
- (d) Observation during:
 - (1) performance on the job,
 - (2) on the job training, or
 - (3) simulations;
- (e) Other forms of assessment.

Qualified means that an individual has been evaluated and can:

- (a) Perform assigned covered tasks and
- (b) Recognize and react to abnormal operating conditions.

[Amdt. 195-67, 64 FR 46866, Aug. 27, 1999, as amended by Amdt. 195-72, 66 FR 43524, Aug. 20, 2001]

§195.505 Qualification program.

Each operator shall have and follow a written qualification program. The program shall include provisions to:

- (a) Identify covered tasks;
- (b) Ensure through evaluation that individuals performing covered tasks are qualified;
- (c) Allow individuals that are not qualified pursuant to this subpart to perform a covered task if directed and observed by an individual that is qualified;
- (d) Evaluate an individual if the operator has reason to believe that the individual's performance of a covered task contributed to an accident as defined in Part 195;
- (e) Evaluate an individual if the operator has reason to believe that the individual is no longer qualified to perform a covered task;
- (f) Communicate changes that affect covered tasks to individuals performing those covered tasks;
- (g) Identify those covered tasks and the intervals at which evaluation of the individual's qualifications is needed;
- (h) After December 16, 2004, provide training, as appropriate, to ensure that individuals performing covered tasks have the necessary knowledge and skills to perform the tasks in a manner that ensures the safe operation of pipeline facilities; and
- (i) After December 16, 2004, notify the Administrator or a state agency participating under 49 U.S.C. Chapter 601 if the operator significantly modifies the program after the Administrator or state agency has verified that it complies with this section. Notifications to PHMSA may be submitted by electronic mail to InformationResourcesManager@dot.gov, or by mail to ATTN: Information Resources Manager DOT/PHMSA/OPS, East Building, 2nd Floor, E22-321, New Jersey Avenue SE., Washington, DC 20590.

[Amdt. 195-67, [64 FR 46866](#), Aug. 27, 1999, as amended by Amdt. 195-84, [70 FR 10336](#), Mar. 3, 2005; Amdt. 195-100, [80 FR 12780](#), Mar. 11, 2015]

§195.507 Recordkeeping.

Each operator shall maintain records that demonstrate compliance with this subpart.

- (a) Qualification records shall include:
 - (1) Identification of qualified individual(s);
 - (2) Identification of the covered tasks the individual is qualified to perform;
 - (3) Date(s) of current qualification; and
 - (4) Qualification method(s).
- (b) Records supporting an individual's current qualification shall be maintained while the individual is performing the covered task. Records of prior qualification and records of individuals no longer performing covered tasks shall be retained for a period of five years.

§195.509 General.

- (a) Operators must have a written qualification program by April 27, 2001. The program must be available for review by the Administrator or by a state agency participating under 49 U.S.C. Chapter 601 if the program is under the authority of that state agency.
- (b) Operators must complete the qualification of individuals performing covered tasks by October 28, 2002.
- (c) Work performance history review may be used as a sole evaluation method for individuals who were performing a covered task prior to October 26, 1999.
- (d) After October 28, 2002, work performance history may not be used as a sole evaluation method.
- (e) After December 16, 2004, observation of on-the-job performance may not be used as the sole method of evaluation.

[Amdt. 195-67, 64 FR 46866, Aug. 27, 1999, as amended by Amdt. 195-72, 66 FR 43524, Aug. 20, 2001; Amdt. 195-84, 70 FR 10336, Mar. 3, 2005]

SubPart H - Corrosion Control (§§551-591)

SubPart H - Corrosion Control

- 195.551 [What do the regulations in this subpart cover?](#)
- 195.553 [What special definitions apply to this subpart?](#)
- 195.555 [What are the qualifications for supervisors?](#)
- 195.557 [Which pipelines must have coating for external corrosion control?](#)
- 195.559 [What coating material may I use for external corrosion control?](#)
- 195.561 [When must I inspect pipe coating used for external corrosion control?](#)
- 195.563 [Which pipelines must have cathodic protection?](#)
- 195.565 [How do I install cathodic protection on breakout tanks?](#)
- 195.567 [Which pipelines must have test leads and how do I install and maintain the leads?](#)
- 195.569 [Do I have to examine exposed portions of buried pipelines?](#)
- 195.571 [What criteria must I use to determine the adequacy of cathodic protection?](#)
- 195.573 [What must I do to monitor external corrosion control?](#)
- 195.575 [Which facilities must I electrically isolate and what inspections, tests, and safeguards are required?](#)
- 195.577 [What must I do to alleviate interference currents?](#)
- 195.579 [What must I do to mitigate internal corrosion?](#)
- 195.581 [Which pipelines must I protect against atmospheric corrosion and what coating material may I use?](#)
- 195.583 [What must I do to monitor atmospheric corrosion control?](#)
- 195.585 [What must I do to correct corroded pipe?](#)
- 195.587 [What methods are available to determine the strength of corroded pipe?](#)
- 195.588 [What standards apply to direct assessment?](#)
- 195.589 [What corrosion control information do I have to maintain?](#)
- 195.591 [In-Line inspection of pipelines](#)

§195.551 What do the regulations in this subpart cover?

This subpart prescribes minimum requirements for protecting steel pipelines against corrosion.

§195.553 What special definitions apply to this subpart?

As used in this subpart -

Active corrosion means continuing corrosion which, unless controlled, could result in a condition that is detrimental to public safety or the environment.

Buried means covered or in contact with soil.

Direct assessment means an integrity assessment method that utilizes a process to evaluate certain threats (i.e., external corrosion, internal corrosion and stress corrosion cracking) to a pipeline segment's integrity. The process includes the gathering and integration of risk factor data, indirect examination or analysis to identify areas of suspected corrosion, direct examination of the pipeline in these areas, and post assessment evaluation.

Electrical survey means a series of closely spaced pipe-to-soil readings over a pipeline that are subsequently analyzed to identify locations where a corrosive current is leaving the pipeline.

External corrosion direct assessment (ECDA) means a four-step process that combines pre-assessment, indirect inspection, direct examination, and post-assessment to evaluate the threat of external corrosion to the integrity of a pipeline.

Pipeline environment includes soil resistivity (high or low), soil moisture (wet or dry), soil contaminants that may promote corrosive activity, and other known conditions that could affect the probability of active corrosion.

You means operator.

[Amdt. 195-73, 66 FR 67004, Dec. 27, 2001, as amended by Amdt. 195-85, 70 FR 61576, Oct. 25, 2005]

§195.555 What are the qualifications for supervisors?

You must require and verify that supervisors maintain a thorough knowledge of that portion of the corrosion control procedures established under § 195.402(c)(3) for which they are responsible for insuring compliance.

§195.557 Which pipelines must have coating for external corrosion control?

Except bottoms of aboveground breakout tanks, each buried or submerged pipeline must have an external coating for external corrosion control if the pipeline is-

- (a) Constructed, relocated, replaced, or otherwise changed after the applicable date in [§ 195.401\(c\)](#), not including the movement of pipe covered by [§ 195.424](#); or
- (b) Converted under [§ 195.5](#) and--
 - (1) Has an external coating that substantially meets [§ 195.559](#) before the pipeline is placed in service; or
 - (2) Is a segment that is relocated, replaced, or substantially altered.

§195.559 What coating material may I use for external corrosion control?

Coating material for external corrosion control under [§195.557](#) must-

- (a) Be designed to mitigate corrosion of the buried or submerged pipeline;
- (b) Have sufficient adhesion to the metal surface to prevent under film migration of moisture;
- (c) Be sufficiently ductile to resist cracking;
- (d) Have enough strength to resist damage due to handling and soil stress;
- (e) Support any supplemental cathodic protection; and
- (f) If the coating is an insulating type, have low moisture absorption and provide high electrical resistance.

[As amended by Amdt 195-73, 66 FR 66993, December 27, 2001]

§195.561 When must I inspect pipe coating used for external corrosion control?

- (a) You must inspect all external pipe coating required by [§ 195.557](#) just prior to lowering the pipe into the ditch or submerging the pipe.
- (b) You must repair any coating damage discovered.

§195.563 Which pipelines must have cathodic protection?

- (a) Each buried or submerged pipeline that is constructed, relocated, replaced, or otherwise changed after the applicable date in [§ 195.401\(c\)](#) must have cathodic protection. The cathodic protection must be in operation not later than 1 year after the pipeline is constructed, relocated, replaced, or otherwise changed, as applicable.
- (b) Each buried or submerged pipeline converted under [§195.5](#) must have cathodic protection if the pipeline--
 - (1) Has cathodic protection that substantially meets [§195.571](#) before the pipeline is placed in service; or
 - (2) Is a segment that is relocated, replaced, or substantially altered.
- (c) All other buried or submerged pipelines that have an effective external coating must have cathodic protection.¹ Except as provided by paragraph (d) of this section, this requirement does not apply to breakout tanks and does not apply to buried piping in breakout tank areas and pumping stations until December 29, 2003.

¹A pipeline does not have an effective external coating material if the current required to cathodically protect the pipeline is substantially the same as if the pipeline were bare.

- (d) Bare pipelines, breakout tank areas, and buried pumping station piping must have cathodic protection in places where regulations in effect before January 28, 2002 required cathodic protection as a result of electrical inspections. See previous editions of this part in 49 CFR, parts 186 to 199.
- (e) Unprotected pipe must have cathodic protection if required by [§195.573\(b\)](#).

§195.565 How do I install cathodic protection on breakout tanks?

This section has been amended by Amdt. 195-107, eff. 6/28/24.

After October 2, 2000, when you install cathodic protection under [§195.563\(a\)](#) to protect the bottom of an aboveground breakout tank of more than 500 barrels 79.49m³ capacity built to API Spec 12F (incorporated by reference, see [§195.3](#)), API Std 620 (incorporated by reference, see [§195.3](#)), API Std 650 (incorporated by reference, see [§195.3](#)), or API Std 650's predecessor, Standard 12C, you must install the system in accordance with API RP 651 (incorporated by reference, see [§195.3](#)). However, you don't need to comply with API RP 651 when installing any tank for which you note in the corrosion control procedures established under [§195.402\(c\)\(3\)](#) why complying with all or certain provisions of API RP 651 is not necessary for the safety of the tank.

[As amended by Amdt. 195-73, 66 FR 66993, Dec. 27, 2001; Amdt. 195-99, 80 FR 168, Jan. 5, 2015; Amdt. 195-107, 89 FR 33264, Apr. 29, 2024]

§195.567 Which pipelines must have test leads and what must I do to install and maintain the leads?

- (a) General. Except for offshore pipelines, each buried or submerged pipeline or segment of pipeline under cathodic protection required by this subpart must have electrical test leads for external corrosion control. However, this requirement does not apply until December 27, 2004 to pipelines or pipeline segments on which test leads were not required by regulations in effect before January 28, 2002.
- (b) Installation. You must install test leads as follows:
 - (1) Locate the leads at intervals frequent enough to obtain electrical measurements indicating the adequacy of cathodic protection.
 - (2) Provide enough looping or slack so backfilling will not unduly stress or break the lead and the lead will otherwise remain mechanically secure and electrically conductive.
 - (3) Prevent lead attachments from causing stress concentrations on pipe.
 - (4) For leads installed in conduits, suitably insulate the lead from the conduit.
 - (5) At the connection to the pipeline, coat each bared test lead wire and bared metallic area with an electrical insulating material compatible with the pipe coating and the insulation on the wire.
- (c) Maintenance. You must maintain the test lead wires in a condition that enables you to obtain electrical measurements to determine whether cathodic protection complies with [§ 195.571](#).

§195.569 Do I have to examine exposed portions of buried pipelines?

Whenever you have knowledge that any portion of a buried pipeline is exposed, you must examine the exposed portion for evidence of external corrosion if the pipe is bare, or if the coating is deteriorated. If you find external corrosion requiring corrective action under [§ 195.585](#), you must investigate circumferentially and longitudinally beyond the exposed portion (by visual examination, indirect method, or both) to determine whether additional corrosion requiring remedial action exists in the vicinity of the exposed portion.

§195.571 What criteria must I use to determine the adequacy of cathodic protection?

Cathodic protection required by this Subpart must comply with one or more of the applicable criteria and other considerations for cathodic protection contained paragraphs 6.2.2, 6.2.3, 6.2.4, 6.2.5 and 6.3 in NACE SP 0169 (incorporated by reference, see [§ 195.3](#)).

[Amdt. 195-100, 80 FR 12781, Mar. 11, 2015]

§195.573 What must I do to monitor external corrosion control?

- (a) *Protected pipelines*. You must do the following to determine whether cathodic protection required by this subpart complies with [§ 195.571](#):

- (1) Conduct tests on the protected pipeline at least once each calendar year, but with intervals not exceeding 15 months. However, if tests at those intervals are impractical for separately protected short sections of bare or ineffectively coated pipelines, testing may be done at least once every 3 calendar years, but with intervals not exceeding 39 months.
- (2) Identify not more than 2 years after cathodic protection is installed, the circumstances in which a close-interval survey or comparable technology is practicable and necessary to accomplish the objectives of paragraph 10.1.1.3 of NACE SP 0169 (incorporated by reference, see § [195.3](#)).
- (b) *Unprotected pipe.* You must reevaluate your unprotected buried or submerged pipe and cathodically protect the pipe in areas in which active corrosion is found, as follows:
- (1) Determine the areas of active corrosion by electrical survey, or where an electrical survey is impractical, by other means that include review and analysis of leak repair and inspection records, corrosion monitoring records, exposed pipe inspection records, and the pipeline environment.
- (2) For the period in the first column, the second column prescribes the frequency of evaluation.

Period	Evaluation frequency
Before December 29, 2003	At least once every 5 calendar years, but with intervals not exceeding 63 months
Beginning December 29, 2003	At least once every 3 calendar years, but with intervals not exceeding 39 months.

- (c) *Rectifiers and other devices.* You must electrically check for proper performance each device in the first column at the frequency stated in the second column.

Device	Check frequency
Rectifier Reverse current switch Diode Interference bond whose failure would jeopardize structural protection	At least six times each calendar year, but with intervals not exceeding 2 ½ months
Other interference bond	At least once each calendar year, but with intervals not exceeding 15 months.

- (d) *Breakout tanks.* You must inspect each cathodic protection system used to control corrosion on the bottom of an aboveground breakout tank to ensure that operation and maintenance of the system are in accordance with API RP 651 (incorporated by reference, see § [195.3](#)). However, this inspection is not required if you note in the corrosion control procedures established under § 195.402(c)(3) why complying with all or certain operation and maintenance provisions of API RP 651 is not necessary for the safety of the tank.
- (e) *Corrective action.* You must correct any identified deficiency in corrosion control as required by § [195.401\(b\)](#). However, if the deficiency involves a pipeline in an integrity management program under § 195.452, you must correct the deficiency as required by § 195.452(h).

[Amdt. 195-73, 66 FR 67004, Dec. 27, 2001; 67 FR 70118, Nov. 20, 2002, as amended by Amdt. 195-86, 71 FR 33411, June 9, 2006; Amdt. 195-94, 75 FR 48607, Aug. 11, 2010; Amdt. 195-99, 80 FR 188, Jan. 5, 2015]

§195.575 Which facilities must I electrically isolate and what inspections, tests, and safeguards are required?

- (a) You must electrically isolate each buried or submerged pipeline from other metallic structures, unless you electrically interconnect and cathodically protect the pipeline and the other structures as a single unit.
- (b) You must install one or more insulating devices where electrical isolation of a portion of a pipeline is necessary to facilitate the application of corrosion control.
- (c) You must inspect and electrically test each electrical isolation to assure the isolation is adequate.
- (d) If you install an insulating device in an area where a combustible atmosphere is reasonable to foresee, you must take precautions to prevent arcing.
- (e) If a pipeline is in close proximity to electrical transmission tower footings, ground cables, or counterpoise, or in other areas where it is reasonable to foresee fault currents or an unusual risk of lightning, you must protect the pipeline against damage from fault currents or lightning and take protective measures at insulating devices.

§195.577 What must I do to alleviate interference currents?

- (a) For pipelines exposed to stray currents, you must have a program to identify, test for, and minimize the detrimental effects of such currents.
- (b) You must design and install each impressed current or galvanic anode system to minimize any adverse effects on existing adjacent metallic structures.

§195.579 What must I do to mitigate internal corrosion?

- (a) *General.* If you transport any hazardous liquid or carbon dioxide that would corrode the pipeline, you must investigate the corrosive effect of the hazardous liquid or carbon dioxide on the pipeline and take adequate steps to mitigate internal corrosion.
- (b) *Inhibitors.* If you use corrosion inhibitors to mitigate internal corrosion, you must-
 - (1) Use inhibitors in sufficient quantity to protect the entire part of the pipeline system that the inhibitors are designed to protect;
 - (2) Use coupons or other monitoring equipment to determine the effectiveness of the inhibitors in mitigating internal corrosion; and
 - (3) Examine the coupons or other monitoring equipment at least twice each calendar year, but with intervals not exceeding 7 1/2 months.
- (c) *Removing pipe.* Whenever you remove pipe from a pipeline, you must inspect the internal surface of the pipe for evidence of corrosion. If you find internal corrosion requiring corrective action under [Sec. 195.585](#), you must investigate circumferentially and longitudinally beyond the removed pipe (by visual examination, indirect method, or both) to determine whether additional corrosion requiring remedial action exists in the vicinity of the removed pipe.
- (d) *Breakout tanks.* After October 2, 2000, when you install a tank bottom lining in an aboveground breakout tank built to API Spec 12F (incorporated by reference, see §195.3), API Std 620 (incorporated by reference, see §195.3), API Std 650 (incorporated by reference, see §195.3), or API Std 650's predecessor, Standard 12C, you must install the lining in accordance with API RP 652 (incorporated by reference, see §195.3). However, you don't need to comply with API RP 652 when

installing any tank for which you note in the corrosion control procedures established under §195.402(c)(3) why compliance with all or certain provisions of API RP 652 is not necessary for the safety of the tank.

[Amdt. 195-73, 66 FR 67004, Dec. 27, 2001, as amended by Amdt. 195-99, 80 FR 188, Jan. 5, 2015]

§195.581 Which pipelines must I protect against atmospheric corrosion and what coating material may I use?

- (a) You must clean and coat each pipeline or portion of pipeline that is exposed to the atmosphere, except pipelines under paragraph (c) of this section.
- (b) Coating material must be suitable for the prevention of atmospheric corrosion.
- (c) Except portions of pipelines in offshore splash zones or soil-to-air interfaces, you need not protect against atmospheric corrosion any pipeline for which you demonstrate by test, investigation, or experience appropriate to the environment of the pipeline that corrosion will-
 - (1) Only be a light surface oxide; or
 - (2) Not affect the safe operation of the pipeline before the next scheduled inspection.

§195.583 What must I do to monitor atmospheric corrosion control?

- (a) You must inspect each pipeline or portion of pipeline that is exposed to the atmosphere for evidence of atmospheric corrosion, as follows:

If the pipeline is located:	Then the frequency of inspection is:
Onshore	At least once every 3 calendar years, but with intervals not exceeding 39 months
Offshore	At least once each calendar year, but with intervals not exceeding 15 months

- (b) During inspections you must give particular attention to pipe at soil-to-air interfaces, under thermal insulation, under disbonded coatings, at pipe supports, in splash zones, at deck penetrations, and in spans over water.
- (c) If you find atmospheric corrosion during an inspection, you must provide protection against the corrosion as required by [§ 195.581](#).

§195.585 What must I do to correct corroded pipe?

- (a) General corrosion. If you find pipe so generally corroded that the remaining wall thickness is less than that required for the maximum operating pressure of the pipeline, you must replace the pipe. However, you need not replace the pipe if you-
 - (1) Reduce the maximum operating pressure commensurate with the strength of the pipe needed for serviceability based on actual remaining wall thickness; or
 - (2) Repair the pipe by a method that reliable engineering tests and analyses show can permanently restore the serviceability of the pipe.

- (b) Localized corrosion pitting. If you find pipe that has localized corrosion pitting to a degree that leakage might result, you must replace or repair the pipe, unless you reduce the maximum operating pressure commensurate with the strength of the pipe based on actual remaining wall thickness in the pits.

§195.587 What methods are available to determine the strength of corroded pipe?

Under §[195.585](#), you may use the procedure in ASME/ANSI B31G (incorporated by reference, see §195.3) or in PRCI PR-3-805 (R- STRENG) (incorporated by reference, see §[195.3](#)) to determine the strength of corroded pipe based on actual remaining wall thickness. These procedures apply to corroded regions that do not penetrate the pipe wall, subject to the limitations set out in the respective procedures.

[Amdt. 195-99, 80 FR 188, Jan. 5, 2015]

§195.588 What standards apply to direct assessment?

This section has been amended by Amdt. 195-107, eff. 6/28/24.

- (a) If you use direct assessment on an onshore pipeline to evaluate the effects of external corrosion or stress corrosion cracking, you must follow the requirements of this section. This section does not apply to methods associated with direct assessment, such as close interval surveys, voltage gradient surveys, or examination of exposed pipelines, when used separately from the direct assessment process.
- (b) The requirements for performing external corrosion direct assessment are as follows:
- (1) General. You must follow the requirements of NACE SP0502 (incorporated by reference, see § [195.3](#)). Also, you must develop and implement a External Corrosion Direct Assessment (ECDA) plan that includes procedures addressing pre-assessment, indirect examination, direct examination, and post-assessment.
 - (2) Pre-assessment. In addition to the requirements in Section 3 of NACE SP0502 (incorporated by reference, see § [195.3](#)), the ECDA plan procedures for pre-assessment must include-
 - (i) Provisions for applying more restrictive criteria when conducting ECDA for the first time on a pipeline segment;
 - (ii) The basis on which you select at least two different, but complementary, indirect assessment tools to assess each ECDA region; and
 - (iii) If you utilize an indirect inspection method not described in Appendix A of NACE SP0502 (incorporated by reference, see § [195.3](#)), you must demonstrate the applicability, validation basis, equipment used, application procedure, and utilization of data for the inspection method.
 - (3) Indirect examination. In addition to the requirements in Section 4 of NACE SP0502 (incorporated by reference, see § [195.3](#)), the procedures for indirect examination of the ECDA regions must include-
 - (i) Provisions for applying more restrictive criteria when conducting ECDA for the first time on a pipeline segment;

- (ii) Criteria for identifying and documenting those indications that must be considered for excavation and direct examination, including at least the following:
 - (A) The known sensitivities of assessment tools;
 - (B) The procedures for using each tool; and
 - (C) The approach to be used for decreasing the physical spacing of indirect assessment tool readings when the presence of a defect is suspected;
 - (iii) For each indication identified during the indirect examination, criteria for-
 - (A) Defining the urgency of excavation and direct examination of the indication; and
 - (B) Defining the excavation urgency as immediate, scheduled, or monitored; and
 - (iv) Criteria for scheduling excavations of indications in each urgency level.
- (4) Direct examination. In addition to the requirements in Section 5 of NACE SP0502 (incorporated by reference, see [§195.3](#)), the procedures for direct examination of indications from the indirect examination must include-
- (i) Provisions for applying more restrictive criteria when conducting ECDA for the first time on a pipeline segment;
 - (ii) Criteria for deciding what action should be taken if either:
 - (A) Corrosion defects are discovered that exceed allowable limits (Section 5.5.2.2 of NACE SP0502 (incorporated by reference, see [§ 195.3](#)) provides guidance for criteria); or
 - (B) Root cause analysis reveals conditions for which ECDA is not suitable (Section 5.6.2 of NACE SP0502 (incorporated by reference, see [§ 195.3](#)) provides guidance for criteria);
 - (iii) Criteria and notification procedures for any changes in the ECDA plan, including changes that affect the severity classification, the priority of direct examination, and the time frame for direct examination of indications; and
 - (iv) Criteria that describe how and on what basis you will reclassify and re-prioritize any of the provisions specified in Section 5.9 of NACE SP0502 (incorporated by reference, see [§ 195.3](#)).
- (5) Post assessment and continuing evaluation. In addition to the requirements in Section 6 of NACE SP 0502 (incorporated by reference, see [§ 195.3](#)), the procedures for post assessment of the effectiveness of the ECDA process must include-
- (i) Measures for evaluating the long-term effectiveness of ECDA in addressing external corrosion in pipeline segments; and
 - (ii) Criteria for evaluating whether conditions discovered by direct examination of indications in each ECDA region indicate a need for reassessment of the pipeline segment at an interval less than that specified in Sections 6.2 and 6.3 of NACE SP0502 (see appendix D of NACE SP0502) (incorporated by reference, see [§ 195.3](#)).
- (c) If you use direct assessment on an onshore pipeline to evaluate the effects of stress corrosion cracking, you must develop and follow a Stress Corrosion Cracking Direct Assessment plan that meets all requirements and recommendations of NACE SP0204 (incorporated by reference, see [§ 195.3](#)) and that implements all four steps of the Stress Corrosion Cracking Direct Assessment process including pre- assessment, indirect inspection, detailed examination and post- assessment. As specified in NACE SP0204, Section 1.1.7, Stress Corrosion Cracking Direct Assessment is complementary with other inspection methods such as in-line inspection or hydrostatic testing and is not necessarily an alternative or replacement for these methods in all instances. In addition, the plan must provide for--

- (1) Data gathering and integration. An operator's plan must provide for a systematic process to collect and evaluate data to identify whether the conditions for stress corrosion cracking are present and to prioritize the segments for assessment in accordance with NACE SP0204- 2008, Sections 3 and 4, and Table 1. This process must also include gathering and evaluating data related to SCC at all sites an operator excavates during the conduct of its pipeline operations (both within and outside covered segments) where the criteria in NACE SP0204-2008 indicate the potential for Stress Corrosion Cracking Direct Assessment. This data gathering process must be conducted in accordance with NACE SP0204-2008, Section 5.3, and must include, at a minimum, all data listed in NACE SP0204-2008, Table 2. Further, an operator must analyze the following factors as part of this evaluation:
 - (i) The effects of a carbonate-bicarbonate environment, including the implications of any factors that promote the production of a carbonate-bicarbonate environment such as soil temperature, moisture, factors that affect the rate of carbon dioxide generation, and/or cathodic protection.
 - (ii) The effects of cyclic loading conditions on the susceptibility and propagation of SCC in both high-pH and near-neutral-pH environments.
 - (iii) The effects of variations in applied cathodic protection such as overprotection, cathodic protection loss for extended periods, and high negative potentials.
 - (iv) The effects of coatings that shield cathodic protection when disbonded from the pipe.
 - (v) Other factors that affect the mechanistic properties associated with SCC including but not limited to operating pressures, high tensile residual stresses, and the presence of sulfides.
- (2) Indirect inspection. In addition to the requirements and recommendations of NACE SP0204-2008, Section 4, the plan's procedures for indirect inspection must include provisions for conducting at least two different, but complementary, indirect assessment electrical surveys, and the basis on the selections as the most appropriate for the pipeline segment based on the data gathering and integration step.
- (3) Direct examination. In addition to the requirements and recommendations of NACE SP0204-2008, Section 5, the plan's procedures for direct examination must provide for conducting a minimum of four direct examinations within the SCC segment at locations determined to be the most likely for SCC to occur.
- (4) Remediation and mitigation. If any indication of SCC is discovered in a segment, an operator must mitigate the threat in accordance with one of the following applicable methods:
 - (i) Non-significant SCC, as defined by NACE SP0204-2008, may be mitigated by either hydrostatic testing in accordance with paragraph (b)(4)(ii) of this section, or by grinding out with verification by Non-Destructive Examination (NDE) methods that the SCC defect is removed and repairing the pipe. If grinding is used for repair, the remaining strength of the pipe at the repair location must be determined using ASME/ANSI B31G or RSTRENG (incorporated by reference, see § [195.3](#)) and must be sufficient to meet the design requirements of [subpart C](#) of this part.
 - (ii) Significant SCC must be mitigated using a hydrostatic testing program with a minimum test pressure between 100% up to 110% of the specified minimum yield strength for a 30-minute spike test immediately followed by a pressure test in accordance with [subpart E](#) of this part. The test pressure for the entire sequence must be continuously maintained for at least 8 hours, in accordance with subpart E of this part. Any test failures due to SCC must be repaired by replacement of the pipe segment, and the segment retested until the pipe passes the complete test without leakage. Pipe segments that have SCC present, but that

pass the pressure test, may be repaired by grinding in accordance with paragraph (c)(4)(i) of this section.

- (5) Post assessment. In addition to the requirements and recommendations of NACE SP0204-2008, sections 6.3, periodic reassessment, and 6.4, effectiveness of Stress Corrosion Cracking Direct Assessment, the plan's procedures for post assessment must include development of a reassessment plan based on the susceptibility of the operator's pipe to Stress Corrosion Cracking as well as on the behavior mechanism of identified cracking. Factors to be considered include, but are not limited to:
- (i) Evaluation of discovered crack clusters during the direct examination step in accordance with NACE SP0204-2008, sections 5.3.5.7, 5.4, and 5.5;
 - (ii) Conditions conducive to creation of the carbonate-bicarbonate environment;
 - (iii) Conditions in the application (or loss) of cathodic protection that can create or exacerbate SCC;
 - (iv) Operating temperature and pressure conditions;
 - (v) Cyclic loading conditions;
 - (vi) Conditions that influence crack initiation and growth rates;
 - (vii) The effects of interacting crack clusters;
 - (viii) The presence of sulfides; and
 - (ix) Disbonded coatings that shield CP from the pipe.

[As amended by Amdt. 195-85, 70 CFR 61571, Oct. 25, 2005; Amdt. 195-94, 75 FR 48593, Aug. 11, 2010; Amdt. 195-101, 82 FR 7972, Jan. 23, 2017; Amdt. 195-107, 89 FR 33264, Apr. 29, 2024]

§195.589 What corrosion control information do I have to maintain?

- (a) You must maintain current records or maps to show the location of-
- (1) Cathodically protected pipelines;
 - (2) Cathodic protection facilities, including galvanic anodes, installed after January 28, 2002; and
 - (3) Neighboring structures bonded to cathodic protection systems.
- (b) Records or maps showing a stated number of anodes, installed in a stated manner or spacing, need not show specific distances to each buried anode.
- (c) You must maintain a record of each analysis, check, demonstration, examination, inspection, investigation, review, survey, and test required by this subpart in sufficient detail to demonstrate the adequacy of corrosion control measures or that corrosion requiring control measures does not exist. You must retain these records for at least 5 years, except that records related to Secs. [195.569](#), [195.573\(a\) and \(b\)](#), and [195.579\(b\)\(3\) and \(c\)](#) must be retained for as long as the pipeline remains in service.

§195.591 In-Line inspection of pipelines.

When conducting in-line inspection of pipelines required by this part, each operator must comply with the requirements and recommendations of API Std 1163, Inline Inspection Systems Qualification Standard; ANSI/ASNT ILI-PQ, Inline Inspection Personnel Qualification and Certification; and NACE SP0102-2010, Inline Inspection of Pipelines (incorporated by reference, see § [195.3](#)). An in-line

inspection may also be conducted using tethered or remote control tools provided they generally comply with those sections of NACE SP0102-2010 that are applicable.

[Amdt. 195-101, 82 FR 8000, Jan. 23, 2017]

Appendix A to Part 195 - Delineation Between Federal and State Jurisdiction—Statement of Agency Policy and Interpretation

Appendix A to Part 195 - Delineation Between Federal and State Jurisdiction—Statement of Agency Policy and Interpretation

Accompanying Drawings

Example 1	Example 2	Example 3	Example 4a	Example 4b	Example 5a	Example 5b
Example 6	Example 7	Example 8	Example 9	Example 10		

In 1979, Congress enacted comprehensive safety legislation governing the transportation of hazardous liquids by pipeline, the Hazardous Liquids Pipeline Safety Act of 1979, 49 U.S.C. 2001 et seq. (HLPISA). The HLPISA expanded the existing statutory authority for safety regulation, which was limited to transportation by common carriers in interstate and foreign commerce, to transportation through facilities used in or affecting interstate or foreign commerce. It also added civil penalty, compliance order, and injunctive enforcement authorities to the existing criminal sanctions. Modeled largely on the Natural Gas Pipeline Safety Act of 1968, 49 U.S.C. 1671 et seq. (NGPSA), the HLPISA provides for a national hazardous liquid pipeline safety program with nationally uniform minimal standards and with enforcement administered through a Federal-State partnership. The HLPISA leaves to exclusive Federal regulation and enforcement the "interstate pipeline facilities," those used for the pipeline transportation of hazardous liquids in interstate or foreign commerce. For the remainder of the pipeline facilities, denominated "intrastate pipeline facilities," the HLPISA provides that the same Federal regulation and enforcement will apply unless a State certifies that it will assume those responsibilities. A certified State must adopt the same minimal standards but may adopt additional more stringent standards so long as they are compatible. Therefore, in States which participate in the hazardous liquid pipeline safety program through certification, it is necessary to distinguish the interstate from the intrastate pipeline facilities.

In deciding that an administratively practical approach was necessary in distinguishing between interstate and intrastate liquid pipeline facilities and in determining how best to accomplish this, DOT has logically examined the approach used in the NGPSA. The NGPSA defines the interstate gas pipeline facilities subject to exclusive Federal jurisdiction as those subject to the economic regulatory jurisdiction of the Federal Energy Regulatory Commission (FERC). Experience has proven this approach practical. Unlike the NGPSA however, the HLPISA has no specific reference to FERC jurisdiction, but instead defines interstate liquid pipeline facilities by the more commonly used means of specifying the end points of the transportation involved. For example, the economic regulatory jurisdiction of FERC over the transportation of both gas and liquids by pipeline is defined in much the same way. In implementing the HLPISA DOT has sought a practicable means of distinguishing between interstate and intrastate pipeline facilities that provide the requisite degree of certainty to Federal and State enforcement personnel and to the regulated entities. DOT intends that this statement of agency policy and interpretation provide that certainty.

In 1981, DOT decided that the inventory of liquid pipeline facilities identified as subject to the jurisdiction of FERC approximates the HLPISA category of "interstate pipeline facilities." Administrative use of the FERC inventory has the added benefit of avoiding the creation of a separate Federal scheme for determination of jurisdiction over the same regulated entities. DOT recognizes that the FERC inventory is only an approximation and may not be totally satisfactory without some modification. The difficulties stem from some significant differences in the economic regulation of liquid and of natural gas

pipelines. There is an affirmative assertion of jurisdiction by FERC over natural gas pipelines through the issuance of certificates of public convenience and necessity prior to commencing operations. With liquid pipelines, there is only a rebuttable presumption of jurisdiction created by the filing by pipeline operators of tariffs (or concurrences) for movement of liquids through existing facilities. Although FERC does police the filings for such matters as compliance with the general duties of common carriers, the question of jurisdiction is normally only aired upon complaint. While any person, including State or Federal agencies can avail themselves of the FERC forum by use of the complaint process, that process has only been rarely used to review jurisdictional matters (probably because of the infrequency of real disputes on the issue). Where the issue has arisen, the reviewing body has noted the need to examine various criteria primarily of an economic nature. DOT believes that, in most cases, the formal FERC forum can better receive and evaluate the type of information that is needed to make decisions of this nature than can DOT.

In delineating which liquid pipeline facilities are interstate pipeline facilities within the meaning of the HLPFA, DOT will generally rely on the FERC filings; that is, if there is a tariff or concurrence filed with FERC governing the transportation of hazardous liquids over a pipeline facility or if there has been an exemption from the obligation to file tariffs obtained from FERC, then DOT will, as a general rule, consider the facility to be an interstate pipeline facility within the meaning of the HLPFA. The types of situations in which DOT will ignore the existence or non-existence of a filing with FERC will be limited to those cases in which it appears obvious that a complaint filed with FERC would be successful or in which blind reliance on a FERC filing would result in a situation clearly not intended by the HLPFA such as a pipeline facility not being subject to either State or Federal safety regulation. DOT anticipates that the situations in which there is any question about the validity of the FERC filings as a ready reference will be few and that the actual variations from reliance on those filings will be rare. The following examples indicate the types of facilities which DOT believes are interstate pipeline facilities subject to the HLPFA despite the lack of a filing with FERC and the types of facilities over which DOT will generally defer to the jurisdiction of a certifying state despite the existence of a filing with FERC.

Example 1. Pipeline company P operates a pipeline from "Point A" located in State X to "Point B" (also in X). The physical facilities never cross a state line and do not connect with any other pipeline which does cross a state line. Pipeline company P also operates another pipeline between "Point C" in State X and "Point D" in an adjoining State Y. Pipeline company P files a tariff with FERC for transportation from "Point A" to "Point B" as well as for transportation from "Point C" to "Point D." DOT will ignore filing for the line from "Point A" to "Point B" and consider the line to be intrastate.

Example 2. Same as in example 1 except that P does not file any tariffs with FERC. DOT will assume jurisdiction of the line between "Point C" and "Point D."

Example 3. Same as in example 1 except that P files its tariff for the line between "Point C" and "Point D" not only with FERC but also with State X. DOT will rely on the FERC filing as indication of interstate commerce.

Example 4. Same as in example 1 except that the pipeline from "Point A" to "Point B" (in State X) connects with a pipeline operated by another company transports liquid between "Point B" (in State X) and "Point D" (in State Y). DOT will rely on the FERC filing as indication of interstate commerce.

Example 5. Same as in example 1 except that the line between "Point C" and "Point D" has a lateral line connected to it. The lateral is located entirely with State X. DOT will rely on the existence or non-existence of a FERC filing covering transportation over that lateral as determinative of interstate commerce.

Example 6. Same as in example 1 except that the certified agency in State X has brought an enforcement action (under the pipeline safety laws) against P because of its operation of the line between "Point A" and "Point B". P has successfully defended against the action on jurisdictional grounds. DOT will assume jurisdiction if necessary to avoid the anomaly of a pipeline subject to neither State or Federal safety

enforcement. DOT's assertion of jurisdiction in such a case would be based on the gap in the state's enforcement authority rather than a DOT decision that the pipeline is an interstate pipeline facility.

Example 7. Pipeline Company P operates a pipeline that originates on the Outer Continental Shelf. P does not file any tariff for that line with FERC. DOT will consider the pipeline to be an interstate pipeline facility.

Example 8. Pipeline Company P is constructing a pipeline from "Point C" (in State X) to "Point D" (in State Y). DOT will consider the pipeline to be an interstate pipeline facility.

Example 9. Pipeline company P is constructing a pipeline from "Point C" to "Point E" (both in State X) but intends to file tariffs with FERC in the transportation of hazardous liquid in interstate commerce. Assuming there is some connection to an interstate pipeline facility, DOT will consider this line to be an interstate pipeline facility.

Example 10. Pipeline Company P has operated a pipeline subject to FERC economic regulation. Solely because of some statutory economic deregulation, that pipeline is no longer regulated by FERC. DOT will continue to consider that pipeline to be an interstate pipeline facility.

As seen from the examples, the types of situations in which DOT will not defer to the FERC regulatory scheme are generally clear-cut cases. For the remainder of the situations where variation from the FERC scheme would require DOT to replicate the forum already provided by FERC and to consider economic factors better left to that agency, DOT will decline to vary its reliance on the FERC filings unless, of course, not doing so would result in situations clearly not intended by the HLPFA.

[Amdt. 195-33, 50 FR 15899, Apr. 23, 1985]

Example Appendix A - 1

PART 195 - LIQUID PIPELINE
INTERSTATE/INTRASTATE DELINEATION

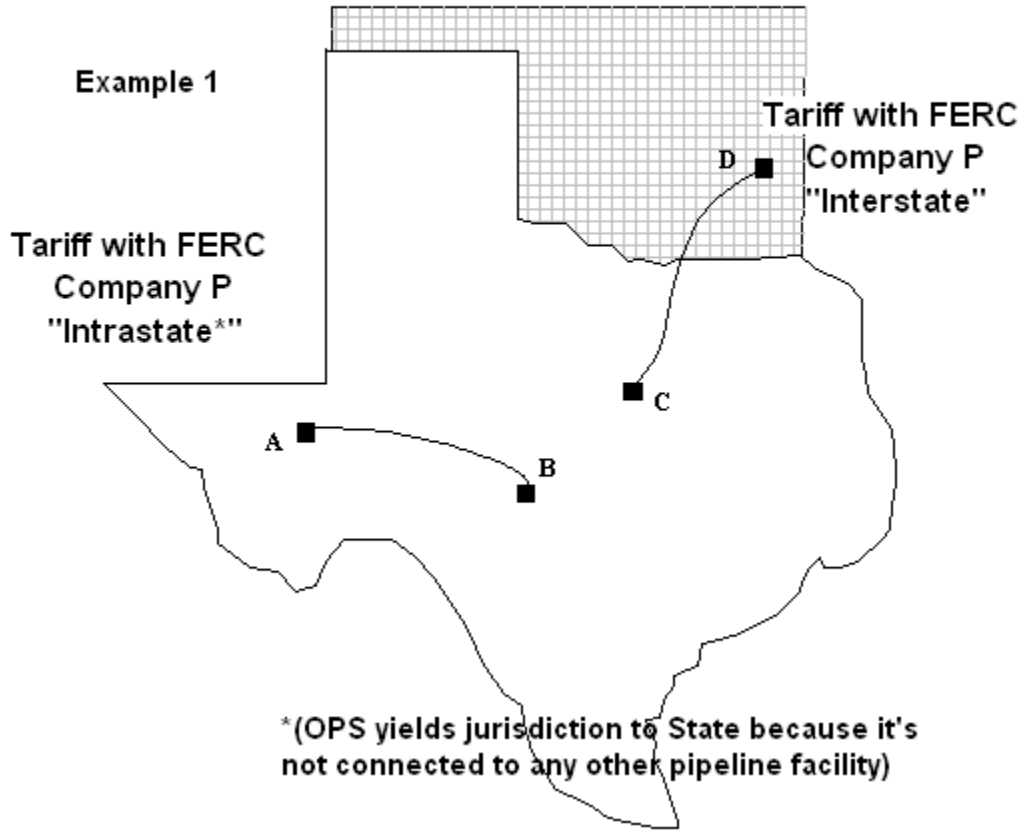

Example Appendix A - 2

PART 195 - LIQUID PIPELINE
INTERSTATE/INTRASTATE DELINEATION

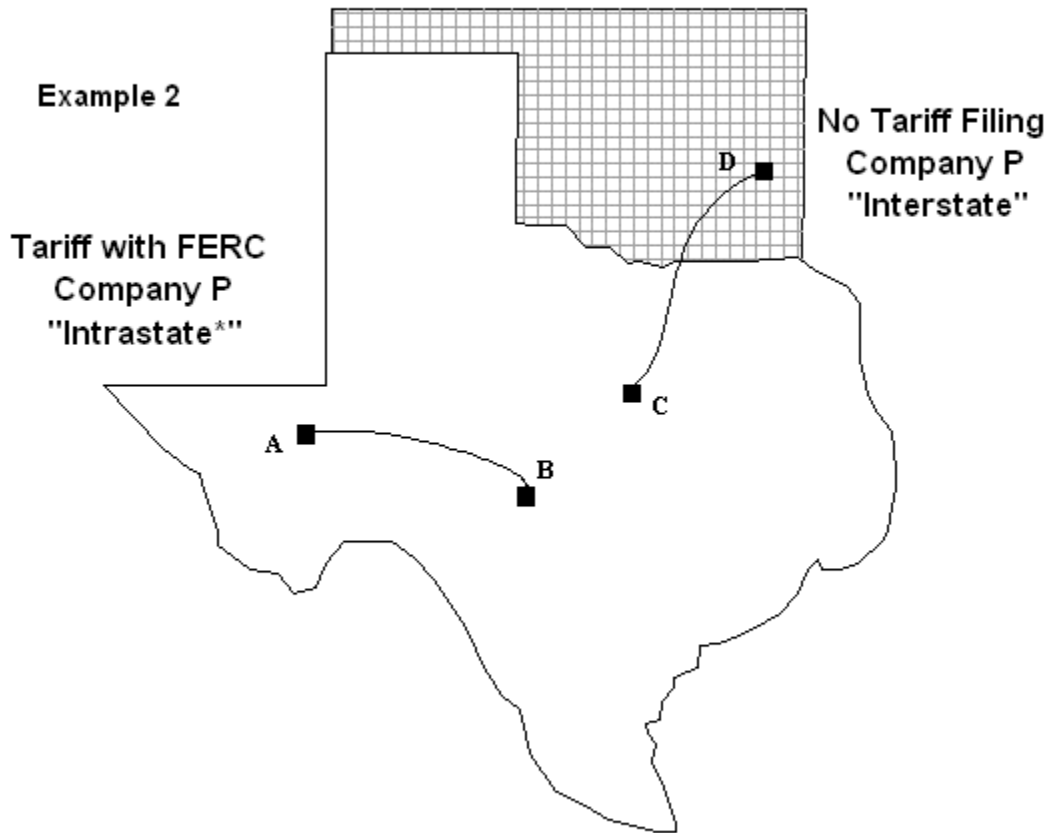

*(OPS yields jurisdiction to State because it's not connected to any other pipeline facility)

Example Appendix A - 3

**PART 195 - LIQUID PIPELINE
INTERSTATE/INTRASTATE DELINEATION**

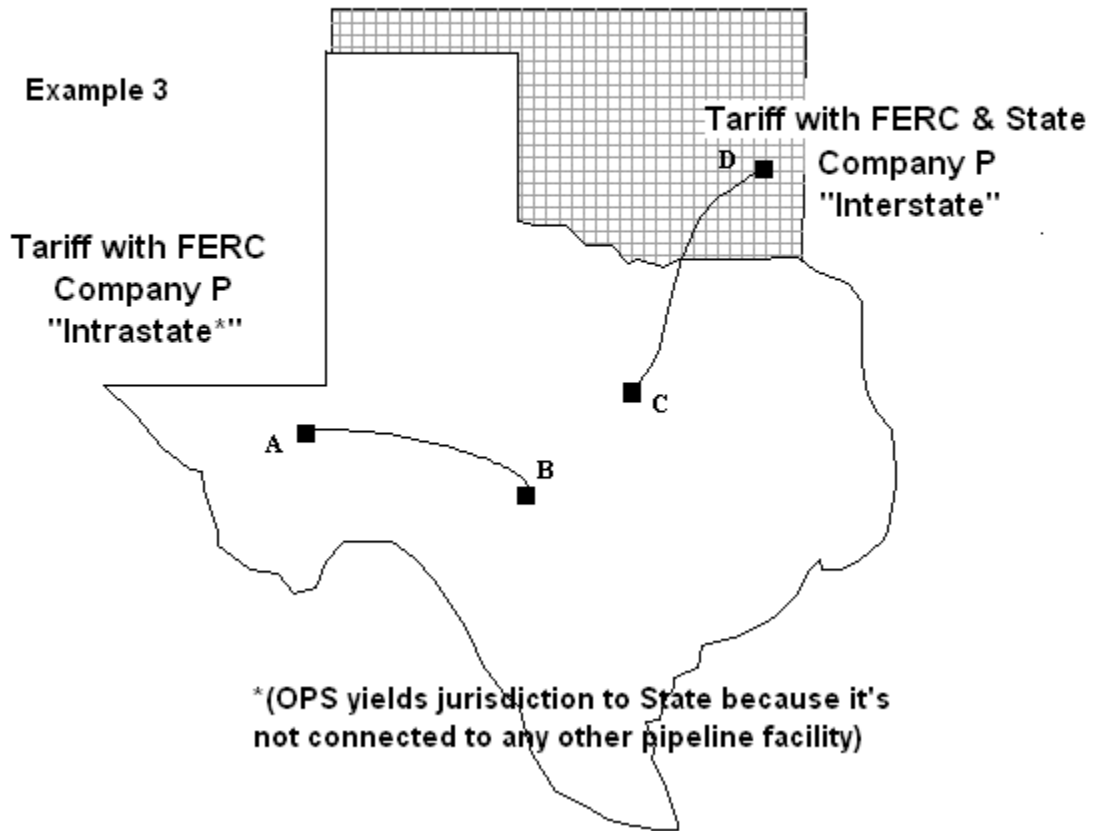

Example Appendix A - 4a

**PART 195 - LIQUID PIPELINE
INTERSTATE/INTRASTATE DELINEATION**

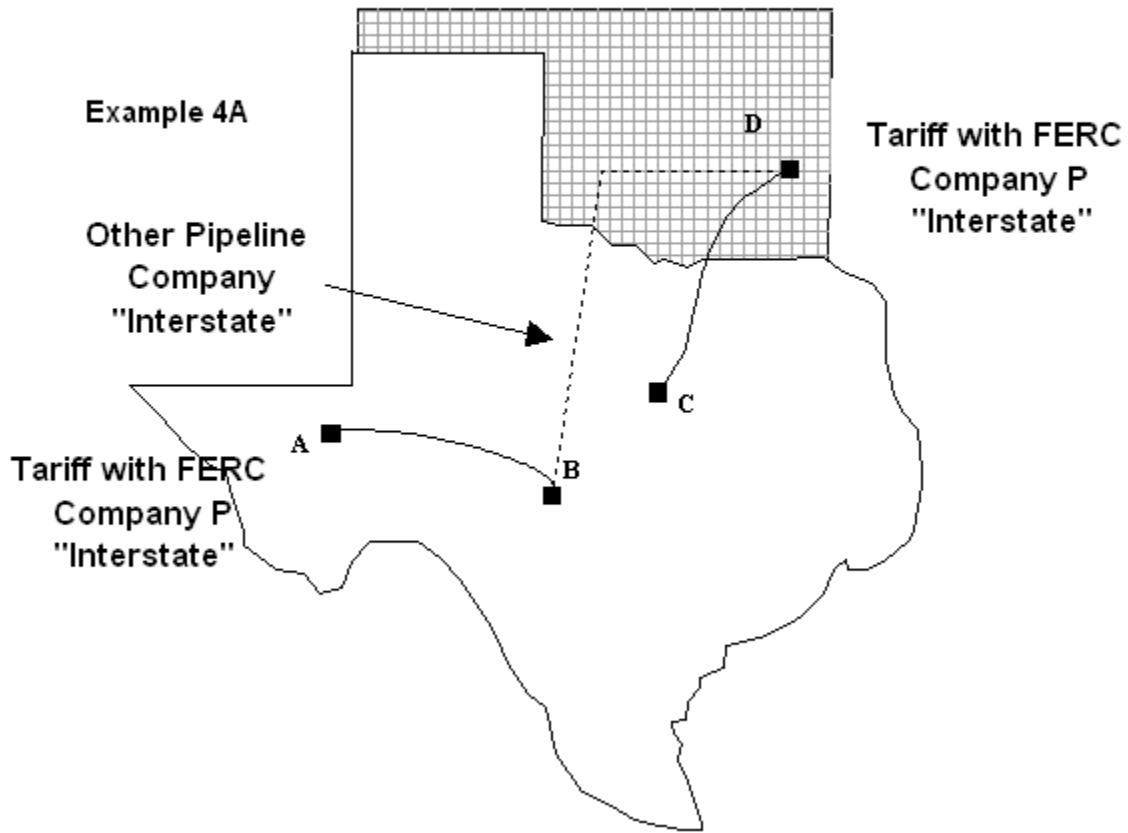

Example Appendix A - 4b

**PART 195 - LIQUID PIPELINE
INTERSTATE/INTRASTATE DELINEATION**

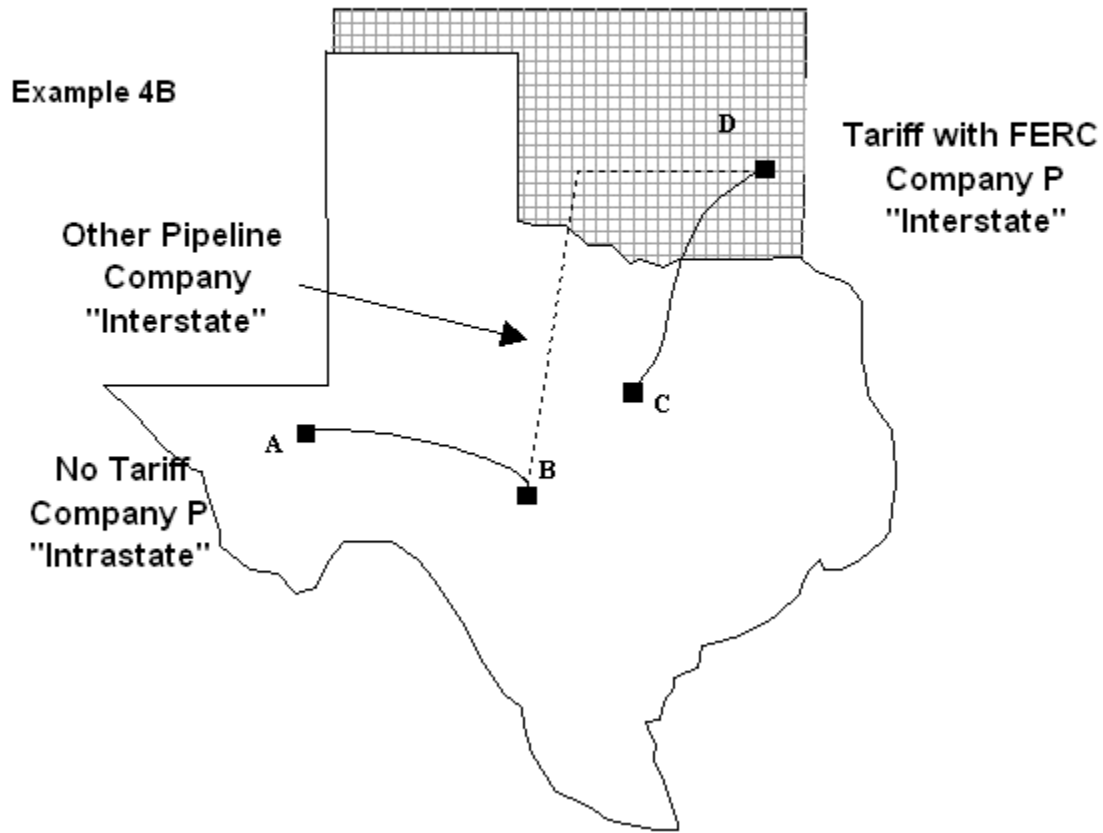

Example Appendix A - 5a

**PART 195 - LIQUID PIPELINE
INTERSTATE/INTRASTATE DELINEATION**

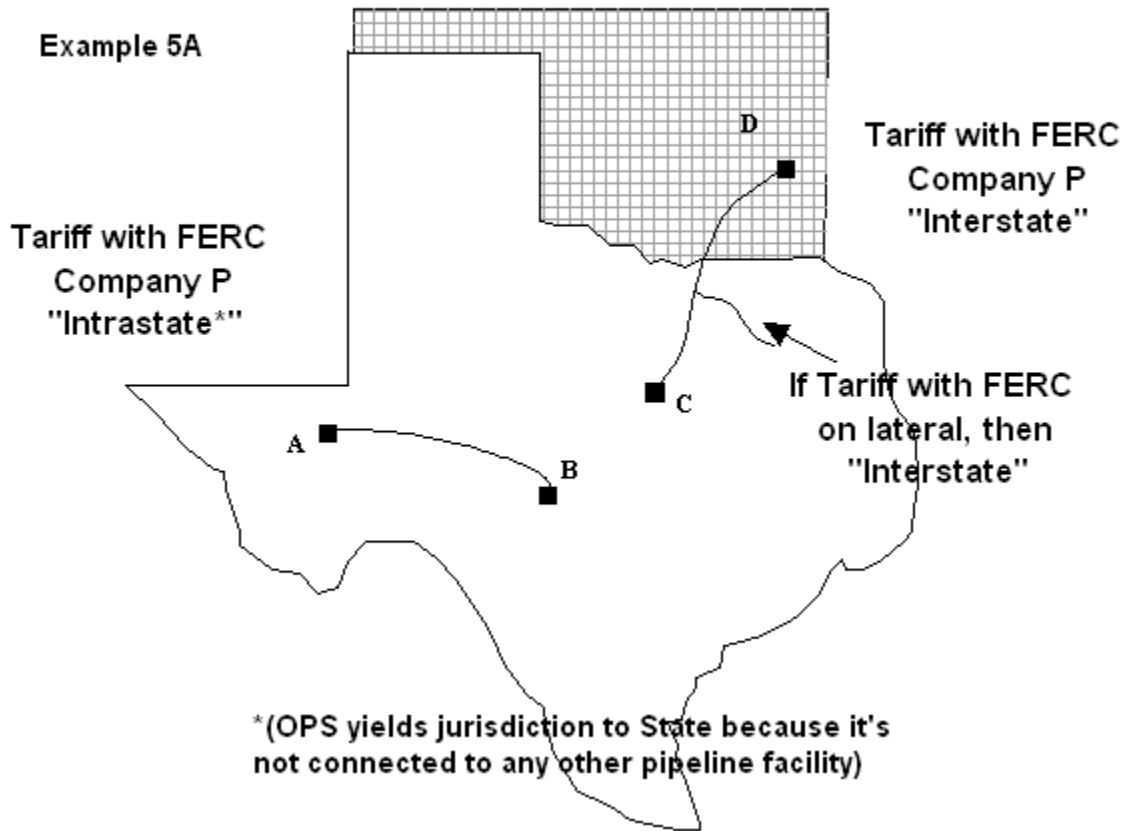

Example Appendix A - 5b

**PART 195 - LIQUID PIPELINE
INTERSTATE/INTRASTATE DELINEATION**

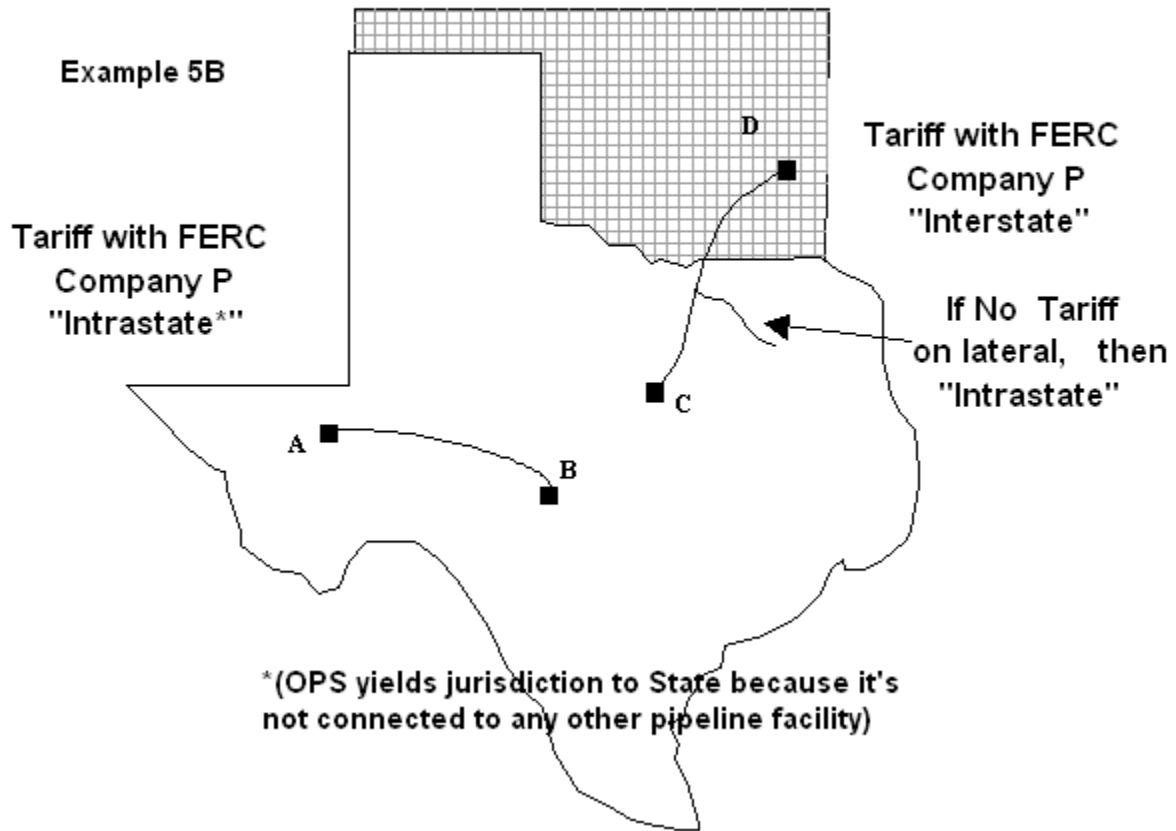

Example Appendix A - 6

**PART 195 - LIQUID PIPELINE
INTERSTATE/INTRASTATE DELINEATION**

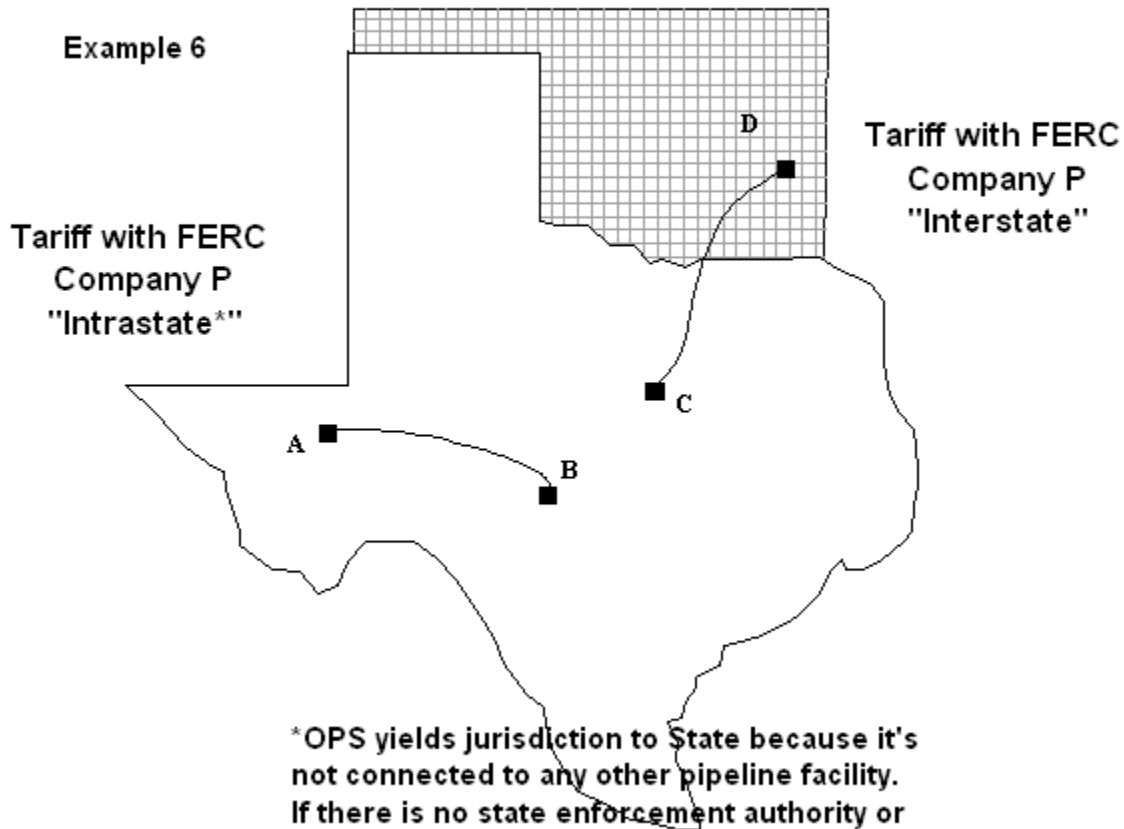

*OPS yields jurisdiction to State because it's not connected to any other pipeline facility. If there is no state enforcement authority or their authority is challenged by the pipeline, then OPS assumes jurisdictional authority.

Example Appendix A - 7

**PART 195 - LIQUID PIPELINE
INTERSTATE/INTRASTATE DELINEATION**

Example 7

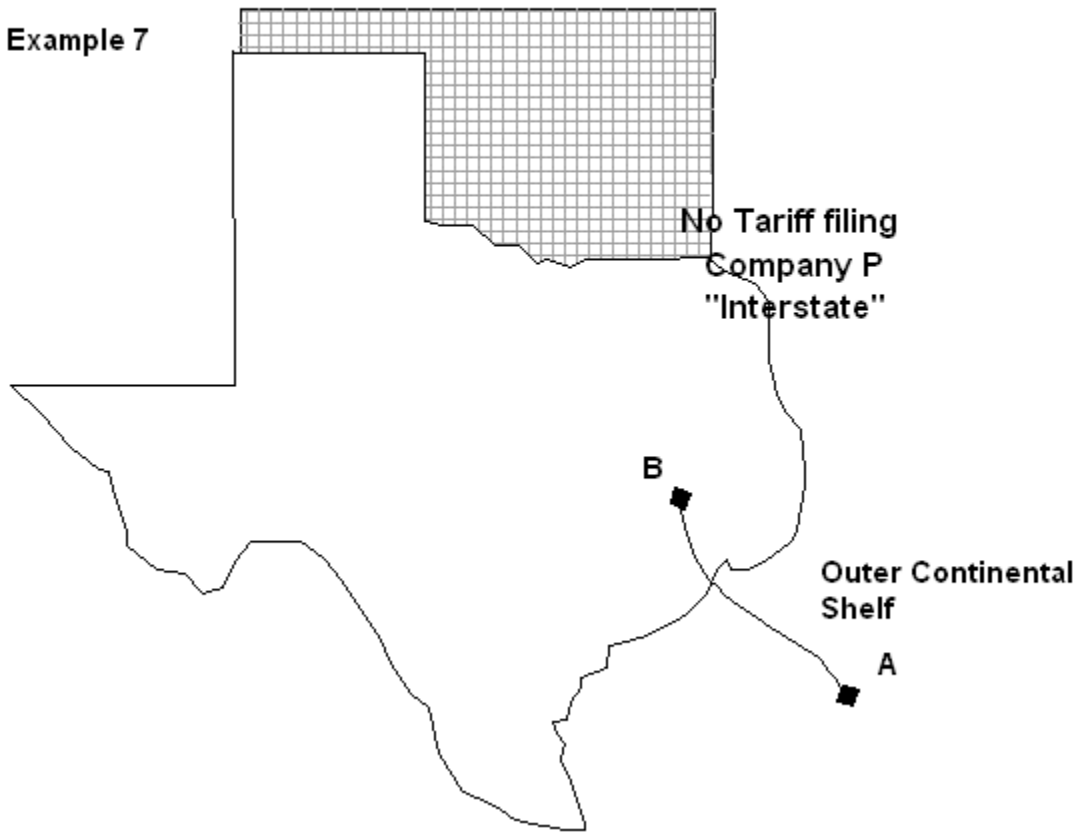

Example Appendix A - 8

**PART 195 - LIQUID PIPELINE
INTERSTATE/INTRASTATE DELINEATION**

Example 8

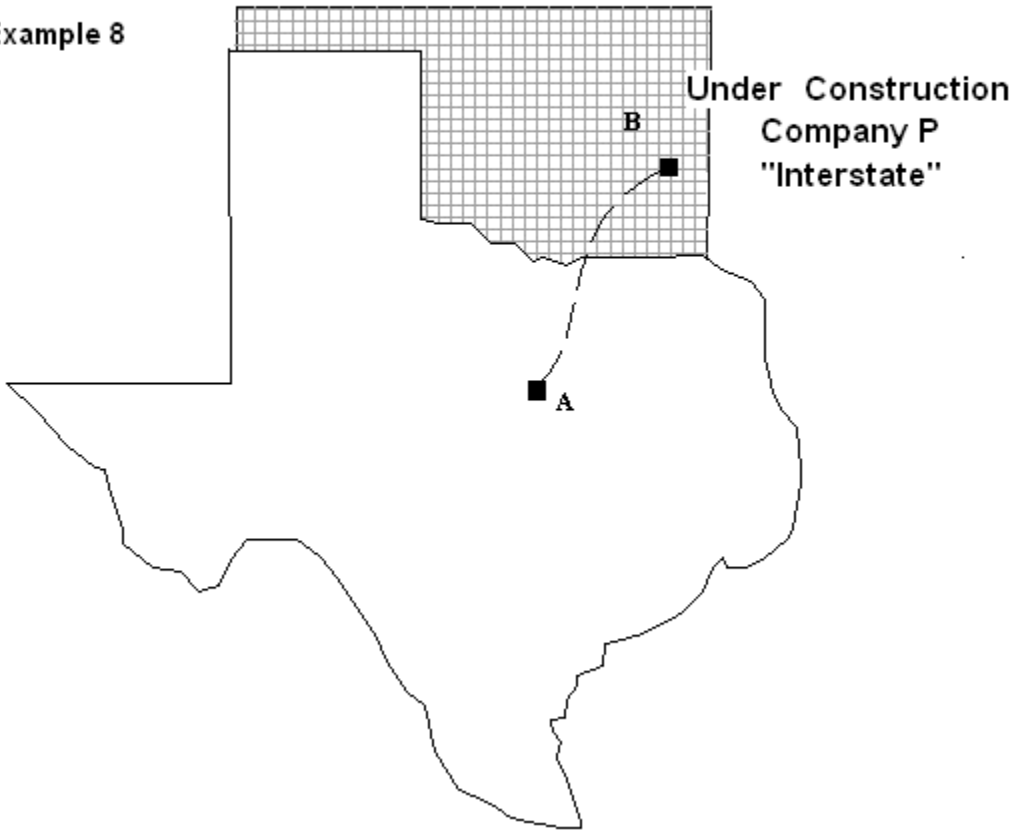

Example Appendix A - 9

**PART 195 - LIQUID PIPELINE
INTERSTATE/INTRASTATE DELINEATION**

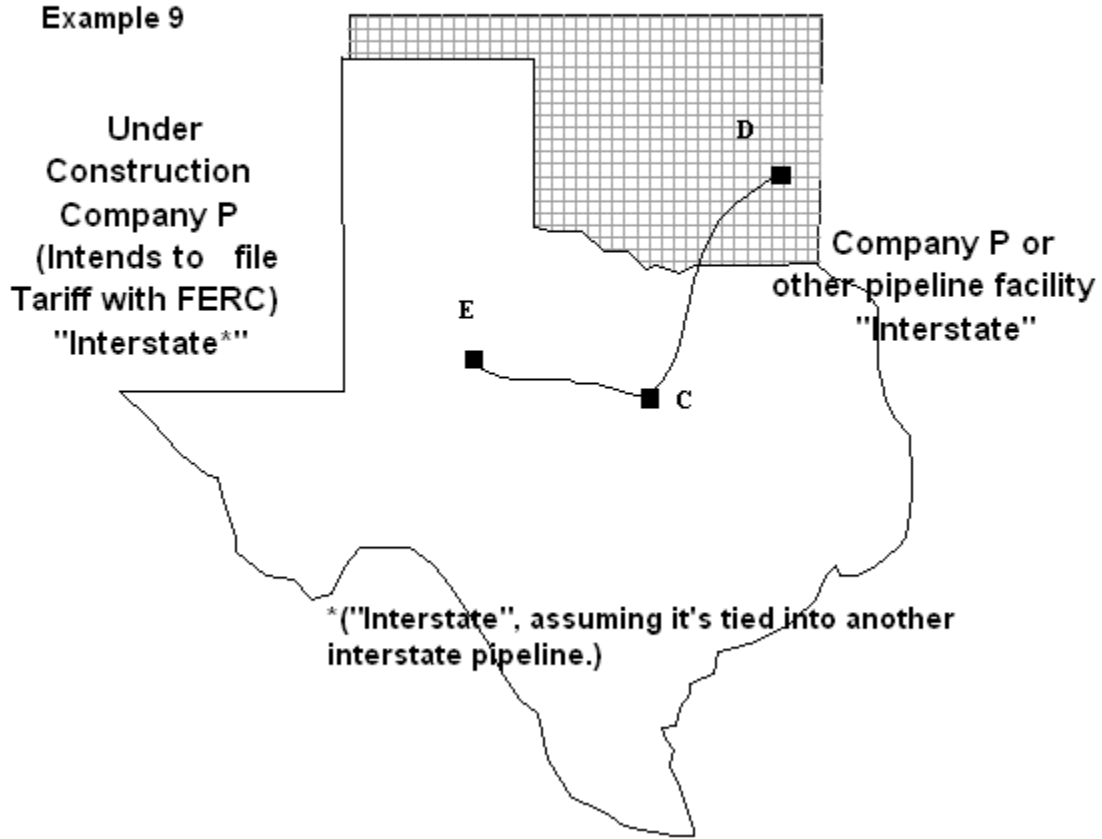

Appendix B to Part 195 - Risk-Based Alternative to Pressure Testing Older Hazardous Liquid and Carbon Dioxide Pipelines

This Appendix provides guidance on how a risk-based alternative to pressure testing older hazardous liquid and carbon dioxide pipelines rule allowed by [§ 195.303](#) will work. This risk-based alternative establishes test priorities for older pipelines, not previously pressure tested, based on the inherent risk of a given pipeline segment. The first step is to determine the classification based on the type of pipe or on the pipeline segment's proximity to populated or environmentally sensitive area. Secondly, the classifications must be adjusted based on the pipeline failure history, product transported, and the release volume potential.

Tables [2](#), [3](#), [4](#), [5](#), and [6](#) give definitions of risk classification A, B, and C facilities. For the purposes of this rule, pipeline segments containing high risk electric resistance-welded pipe (ERW pipe) and lapwelded pipe manufactured prior to 1970 and considered a risk classification C or B facility shall be treated as the top priority for testing because of the higher risk associated with the susceptibility of this pipe to longitudinal seam failures.

In all cases, operators shall annually, at intervals not to exceed 15 months, review their facilities to reassess the classification and shall take appropriate action within two years or operate the pipeline system at a lower pressure. Pipeline failures, changes in the characteristics of the pipeline route, or changes in service should all trigger a reassessment of the originally classification.

[Table 1](#) explains different levels of test requirements depending on the inherent risk of a given pipeline segment. The overall risk classification is determined based on the type of pipe involved, the facility's location, the product transported, the relative volume of flow and pipeline failure history as determined from Tables 2-6.

Table 1. Test Requirements-Mainline Segments Outside of Terminals, Stations, and Tank Farms

Pipeline segment	Risk classification	Test deadline ¹	Test medium
Pre-1970 Pipeline Segments susceptible to longitudinal seam ²	C or B	12/7/2000 ³	Water only.
	A	12/7/2002 ⁵	Water only.
All Other Pipeline Segments	C	12/7/2002 ⁴	Water only.
	B	12/7/2004 ⁴	Water/Liq. ⁵
	A	Additional pressure testing not required	

¹ If operational experience indicates a history of past failures for a particular pipeline segment, failure causes (time-dependent defects due to corrosion, construction, manufacture, or transmission problems, etc.) shall be reviewed in determining risk classification (See [Table 6](#)) and the timing of the pressure test should be accelerated.

² All pre-1970 ERW pipeline segments may not require testing. In determining which ERW pipeline segments should be included in this category, an operator must consider the seam-related leak history of the pipe and pipe manufacturing information as available, which may include the pipe steel's mechanical properties, including fracture toughness; the manufacturing process and controls related to seam properties, including whether the ERW process was high-frequency or low-frequency, whether the weld seam was heat treated, whether the seam was inspected, the test pressure and duration during mill hydrotest; the quality control of the steel-making process; and other factors pertinent to seam properties and quality.

³ For those pipeline operators with extensive mileage of pre-1970 ERW pipe, any waiver requests for timing relief should be supported by an assessment of hazards in accordance with location, product, volume, and probability of failure considerations consistent with Tables 3, 4, 5, and 6.

⁴ A magnetic flux leakage or ultrasonic internal inspection survey may be utilized as an alternative to pressure testing where leak history and operating experience do not indicate leaks caused by longitudinal cracks or seam failures.

⁵ Pressure tests utilizing a hydrocarbon liquid may be conducted, but only with a liquid which does not vaporize rapidly.

Using LOCATION, PRODUCT, VOLUME, and FAILURE HISTORY "Indicators" from Tables 3, 4, 5, and 6 respectively, the overall risk classification of a given pipeline or pipeline segment can be established from Table 2. The LOCATION Indicator is the primary factor which determines overall risk, with the PRODUCT, VOLUME, and PROBABILITY OF FAILURE Indicators used to adjust to a higher or lower overall risk classification per the following table.

Table 2. Risk Classification

Risk classification	Hazard location indicator	Product/volume indicator	Probability of failure indicator
A	L or H	L/L	L
B		Not A or C Risk Classification	
C	H	Any	Any

H=High M=Moderate L=Low.

Note: For Location, Product, Volume, and Probability of Failure Indicators, see Tables 3, 4, 5, and 6. Table 3 is used to establish the LOCATION Indicator used in Table 2. Based on the population and environment characteristics associated with a pipeline facility's location, a LOCATION Indicator of H, M or L is selected.

Table 3. Location Indicators-Pipeline Segments

Indicator	Population ¹	Environment ²
H	Non-rural areas	Environmentally sensitive ² areas.
M		
L	Rural areas	Not environmentally sensitive ² areas.

¹ The effects of potential vapor migration should be considered for pipeline segments transporting highly volatile or toxic products.

² We expect operators to use their best judgment in applying this factor.

Tables 4, 5, and 6, are used to establish the PRODUCT, VOLUME, and PROBABILITY OF FAILURE Indicators respectively, in Table 2. The PRODUCT Indicator is selected from Table 4 as H, M, or L based on the acute and chronic hazards associated with the product transported. The VOLUME Indicator is selected from Table 5 as H, M, or L based on the nominal diameter of the pipeline. The Probability of Failure Indicator is selected from Table 6.

Table 4. Product Indicators

Indicator	Considerations	Product examples
H	(Highly volatile and flammable).	(Propane, butane, Natural Gas Liquid(NGL), ammonia)
	Highly toxic	(Benzene, high Hydrogen Sulfide content crude oils)

Appendix B to Part 195 - Risk-Based Alternative to Pressure Testing Older Hazardous Liquid and Carbon Dioxide Pipelines

M	Flammable--flashpoint <100F	(Gasoline, JP4, low flashpoint crude oils).
L	Non-flammable-- flashpoint 100+F	(Diesel, fuel oil, kerosene, JP5, most crude oils).
	Highly volatile and non-flammable/non-toxic.	Carbon Dioxide.

Considerations: The degree of acute and chronic toxicity to humans, wildlife, and aquatic life; reactivity; and, volatility, flammability, and water solubility determine the Product Indicator. Comprehensive Environmental Response, Compensation and Liability Act Reportable Quantity values can be used as an indication of chronic toxicity. National Fire Protection Association health factors can be used for rating acute hazards.

Table 5. Volume Indicators

Indicator	Line size
H	>= 18".
M	10"-16" nominal diameters.
L	<= 8" nominal diameter.

H=High M=Moderate L=Low.

Table 6 is used to establish the PROBABILITY OF FAILURE Indicator used in [Table 2](#). The "Probability of Failure" Indicator is selected from Table 6 as H or L.

Table 6. Probability of Failure Indicators [in each haz. location]

Indicator	Failure history (time-dependent defects) ²
H ¹	>Three spills in last 10 years.
L	<= Three spills in last 10 years.

H=High L=Low.

¹ Pipeline segments with greater than three product spills in the last 10 years should be reviewed for failure causes as described in subnote ². The pipeline operator should make an appropriate investigation and reach a decision based on sound engineering judgment, and be able to demonstrate the basis of the decision.

² Time-Dependent Defects are defects that result in spills due to corrosion, gouges, or problems developed during manufacture, construction or operation, etc.

[Amdt. 195-65, 63 FR 59480, Nov. 4, 1998; 64 FR 6815, Feb. 11, 1999]

Appendix C to Part 195 - Guidance for Implementation of an Integrity Management Program

This Appendix gives guidance to help an operator implement the requirements of the integrity management program rule in §§ [195.450](#) and 195.452. Guidance is provided on:

- (1) Information an operator may use to identify a high consequence area and factors an operator can use to consider the potential impacts of a release on an area;
- (2) Risk factors an operator can use to determine an integrity assessment schedule;
- (3) Safety risk indicator tables for leak history, volume or line size, age of pipeline, and product transported, an operator may use to determine if a pipeline segment falls into a high, medium or low risk category;
- (4) Types of internal inspection tools an operator could use to find pipeline anomalies;
- (5) Measures an operator could use to measure an integrity management program's performance; and
- (6) Types of records an operator will have to maintain.
- (7) Types of conditions that an integrity assessment may identify that an operator should include in its required schedule for evaluation and remediation.

I. Identifying a high consequence area and factors for considering a pipeline segment's potential impact on a high consequence area.

- A. The rule defines a High Consequence Area as a high population area, an other populated area, an unusually sensitive area, or a commercially navigable waterway. The Office of Pipeline Safety (OPS) will map these areas on the National Pipeline Mapping System (NPMS). An operator, member of the public or other government agency may view and download the data from the NPMS home page <http://www.npms.phmsa.gov/>. OPS will maintain the NPMS and update it periodically. However, it is an operator's responsibility to ensure that it has identified all high consequence areas that could be affected by a pipeline segment. An operator is also responsible for periodically evaluating its pipeline segments to look for population or environmental changes that may have occurred around the pipeline and to keep its program current with this information. (Refer to § 195.452(d)(3).)
 - (1) Digital Data on populated areas available on U.S. Census Bureau maps.
 - (2) Geographic Database on the commercial navigable waterways available on <http://www.bts.gov/gis/ntatlas/networks.html>.
 - (3) The Bureau of Transportation Statistics database that includes commercially navigable waterways and non-commercially navigable waterways. The database can be downloaded from the BTS website at <http://www.bts.gov/gis/ntatlas/networks.html>.
- B. The rule requires an operator to include a process in its program for identifying which pipeline segments could affect a high consequence area and to take measures to prevent and mitigate the consequences of a pipeline failure that could affect a high consequence area. (See §§ 195.452 (f) and (i).) Thus, an operator will need to consider how each pipeline segment could affect a high consequence area. The primary source for the listed risk factors is a US DOT study on instrumented Internal Inspection devices (November 1992). Other sources include the National Transportation Safety Board, the Environmental Protection Agency and the Technical Hazardous Liquid Pipeline Safety Standards Committee. The following list provides guidance to an operator on both the mandatory and additional factors:
 - (1) Terrain surrounding the pipeline. An operator should consider the contour of the land profile and if it could allow the liquid from a release to enter a high consequence area. An

operator can get this information from topographical maps such as U.S. Geological Survey quadrangle maps.

- (2) Drainage systems such as small streams and other smaller waterways that could serve as a conduit to a high consequence area.
- (3) Crossing of farm tile fields. An operator should consider the possibility of a spillage in the field following the drain tile into a waterway.
- (4) Crossing of roadways with ditches along the side. The ditches could carry a spillage to a waterway.
- (5) The nature and characteristics of the product the pipeline is transporting (refined products, crude oils, highly volatile liquids, etc.) Highly volatile liquids becomes gaseous when exposed to the atmosphere. A spillage could create a vapor cloud that could settle into the lower elevation of the ground profile.
- (6) Physical support of the pipeline segment such as by a cable suspension bridge. An operator should look for stress indicators on the pipeline (strained supports, inadequate support at towers), atmospheric corrosion, vandalism, and other obvious signs of improper maintenance.
- (7) Operating conditions of the pipeline (pressure, flow rate, etc.). Exposure of the pipeline to an operating pressure exceeding the established maximum operating pressure.
- (8) The hydraulic gradient of the pipeline.
- (9) The diameter of the pipeline, the potential release volume, and the distance between the isolation points.
- (10) Potential physical pathways between the pipeline and the high consequence area.
- (11) Response capability (time to respond, nature of response).
- (12) Potential natural forces inherent in the area (flood zones, earthquakes, subsidence areas, etc.)

II. Risk factors for establishing frequency of assessment.

- A. By assigning weights or values to the risk factors, and using the risk indicator tables, an operator can determine the priority for assessing pipeline segments, beginning with those segments that are of highest risk, that have not previously been assessed. This list provides some guidance on some of the risk factors to consider (see §195.452(e)). An operator should also develop factors specific to each pipeline segment it is assessing, including:
 - (1) Populated areas, unusually sensitive environmental areas, National Fish Hatcheries, commercially navigable waters, areas where people congregate.
 - (2) Results from previous testing/inspection. (See §195.452(h).)
 - (3) Leak History. (See leak history risk table.)
 - (4) Known corrosion or condition of pipeline. (See §195.452(g).)
 - (5) Cathodic protection history.
 - (6) Type and quality of pipe coating (disbonded coating results in corrosion).
 - (7) Age of pipe (older pipe shows more corrosion - may be uncoated or have an ineffective coating) and type of pipe seam. (See Age of Pipe risk table.)
 - (8) Product transported (highly volatile, highly flammable and toxic liquids present a greater threat for both people and the environment) (see Product transported risk table.)
 - (9) Pipe wall thickness (thicker walls give a better safety margin)
 - (10) Size of pipe (higher volume release if the pipe ruptures).

- (11) Location related to potential ground movement (e.g., seismic faults, rock quarries, and coal mines); climatic (permafrost causes settlement - Alaska); geologic (landslides or subsidence).
- (12) Security of throughput (effects on customers if there is failure requiring shutdown).
- (13) Time since the last internal inspection/pressure testing.
- (14) With respect to previously discovered defects/anomalies, the type, growth rate, and size.
- (15) Operating stress levels in the pipeline.
- (16) Location of the pipeline segment as it relates to the ability of the operator to detect and respond to a leak. (e.g., pipelines deep underground, or in locations that make leak detection difficult without specific sectional monitoring and/or significantly impede access for spill response or any other purpose).
- (17) Physical support of the segment such as by a cable suspension bridge.
- (18) Non-standard or other than recognized industry practice on pipeline installation (e.g., horizontal directional drilling).

B. Example: This example illustrates a hypothetical model used to establish an integrity assessment schedule for a hypothetical pipeline segment. After we determine the risk factors applicable to the pipeline segment, we then assign values or numbers to each factor, such as, high (5), moderate (3), or low (1). We can determine an overall risk classification (A, B, C) for the segment using the risk tables and a sliding scale (values 5 to 1) for risk factors for which tables are not provided. We would classify a segment as C if it fell above 2/3 of maximum value (highest overall risk value for any one segment when compared with other segments of a pipeline), a segment as B if it fell between 1/3 to 2/3 of maximum value, and the remaining segments as A.

- i. For the baseline assessment schedule, we would plan to assess 50% of all pipeline segments covered by the rule, beginning with the highest risk segments, within the first 3½ years and the remaining segments within the seven-year period. For the continuing integrity assessments, we would plan to assess the C segments within the first two (2) years of the schedule, the segments classified as moderate risk no later than year three or four and the remaining lowest risk segments no later than year five (5).
- ii. For our hypothetical pipeline segment, we have chosen the following risk factors and obtained risk factor values from the appropriate table. The values assigned to the risk factors are for illustration only.

Age of pipeline: assume 30 years old (refer to "Age of Pipeline" risk table) -

Risk Value=5

Pressure tested: tested once during construction -

Risk Value=5

Coated: (yes/no) -

yes

Coating Condition: Recent excavation of suspected areas showed holidays in coating (potential corrosion risk) -

Risk Value=5

Cathodically Protected: (yes/no) - yes -

Risk Value=1

Date cathodic protection installed: five years after pipeline was constructed (Cathodic protection installed within one year of the pipeline's construction is generally considered low risk.) -

Risk Value=3

Close interval survey: (yes/no) - no -

Risk Value =5

Internal Inspection tool used: (yes/no) - yes. Date of pig run? In last five years -

Risk Value=1

Anomalies found: (yes/no) - yes, but do not pose an immediate safety risk or environmental hazard -

Risk Value=3

Leak History: yes, one spill in last 10 years. (refer to "Leak History" risk table) -

Risk Value=2

Product transported: Diesel fuel. Product low risk. (refer to "Product" risk table) -

Risk Value=1

Pipe size: 16 inches. Size presents moderate risk (refer to "Line Size" risk table) -

Risk Value=3

- iii. Overall risk value for this hypothetical segment of pipe is 34. Assume we have two other pipeline segments for which we conduct similar risk rankings. The second pipeline segment has an overall risk value of 20, and the third segment, 11. For the baseline assessment we would establish a schedule where we assess the first segment (highest risk segment) within two years, the second segment within five years and the third segment within seven years. Similarly, for the continuing integrity assessment, we could establish an assessment schedule where we assess the highest risk segment no later than the second year, the second segment no later than the third year, and the third segment no later than the fifth year.

III. Safety risk indicator tables for leak history, volume or line size, age of pipeline, and product transported.

Leak History	
Safety risk indicator	Leak history (Time-dependent defects) ¹
High	> 3 Spills in last 10 years
Low	< 3 Spills in last 10 years

¹ Time-dependent defects are those that result in spills due to corrosion, gouges, or problems developed during manufacture, construction or operation, etc.

Line size or Volume transported	
Safety risk indicator	Line size
High	≥ 18'
Moderate	10'-16' nominal diameters
Low	≤ 8' nominal diameter
Age of Pipeline	

Safety risk indicator	Age Pipeline condition dependent ¹
High	> 25 years
Low	< 25 years

¹ Depends on pipeline's coating & corrosion condition, and steel quality, toughness, welding.

Product Transported		
Safety risk indicator	Considerations ¹	Product examples
High	(Highly volatile and flammable)	(Propane, butane, Natural Gas Liquid (NGL), ammonia).
	Highly toxic	(Benzene, high Hydrogen Sulfide content crude oils).
Medium	Flammable-flashpoint <100F	(Gasoline, JP4, low flashpoint crude oils).
Low	Non-flammable - flashpoint 100+F	(Diesel, fuel oil, kerosene, JP5, most crude oils).

¹ The degree of acute and chronic toxicity to humans, wildlife, and aquatic life; reactivity; and, volatility, flammability, and water solubility determine the Product Indicator. Comprehensive Environmental Response, Compensation and Liability Act Reportable Quantity values may be used as an indication of chronic toxicity. National Fire Protection Association health factors may be used for rating acute hazards.

IV. Types of internal inspection tools to use.

An operator should consider at least two types of internal inspection tools for the integrity assessment from the following list. The type of tool or tools an operator selects will depend on the results from previous internal inspection runs, information analysis and risk factors specific to the pipeline segment:

- (1) Geometry Internal inspection tools for detecting changes to ovality, e.g., bends, dents, buckles or wrinkles, due to construction flaws or soil movement, or other outside force damage;
- (2) Metal Loss Tools (Ultrasonic and Magnetic Flux Leakage) for determining pipe wall anomalies, e.g., wall loss due to corrosion.
- (3) Crack Detection Tools for detecting cracks and crack-like features, e.g., stress corrosion cracking (SCC), fatigue cracks, narrow axial corrosion, toe cracks, hook cracks, etc.

V. Methods to measure performance.

A. General.

- (1) This guidance is to help an operator establish measures to evaluate the effectiveness of its integrity management program. The performance measures required will depend on the details of each integrity management program and will be based on an understanding and analysis of the failure mechanisms or threats to integrity of each pipeline segment.
- (2) An operator should select a set of measurements to judge how well its program is performing. An operator's objectives for its program are to ensure public safety, prevent or minimize leaks and spills and prevent property and environmental damage. A typical integrity management program will be an ongoing program and it may contain many elements. Therefore, several performance measure are likely to be needed to measure the effectiveness of an ongoing program.

B. Performance measures.

These measures show how a program to control risk on pipeline segments that could affect a high consequence area is progressing under the integrity management requirements. Performance measures generally fall into three categories:

- (1) Selected Activity Measures - Measures that monitor the surveillance and preventive activities the operator has implemented. These measure indicate how well an operator is implementing the various elements of its integrity management program.
- (2) Deterioration Measures - Operation and maintenance trends that indicate when the integrity of the system is weakening despite preventive measures. This category of performance measure may indicate that the system condition is deteriorating despite well executed preventive activities.
- (3) Failure Measures - Leak History, incident response, product loss, etc. These measures will indicate progress towards fewer spills and less damage.

C. Internal vs. External Comparisons.

These comparisons show how a pipeline segment that could affect a high consequence area is progressing in comparison to the operator's other pipeline segments that are not covered by the integrity management requirements and how that pipeline segment compares to other operators' pipeline segments.

- (1) Internal - Comparing data from the pipeline segment that could affect the high consequence area with data from pipeline segments in other areas of the system may indicate the effects from the attention given to the high consequence area.
- (2) External - Comparing data external to the pipeline segment (e.g., OPS incident data) may provide measures on the frequency and size of leaks in relation to other companies.

D. Examples.

Some examples of performance measures an operator could use include-

- (1) A performance measurement goal to reduce the total volume from unintended releases by -% (percent to be determined by operator) with an ultimate goal of zero.
- (2) A performance measurement goal to reduce the total number of unintended releases (based on a threshold of 5 gallons) by ____-% (percent to be determined by operator) with an ultimate goal of zero.
- (3) A performance measurement goal to document the percentage of integrity management activities completed during the calendar year.
- (4) A performance measurement goal to track and evaluate the effectiveness of the operator's community outreach activities.
- (5) A narrative description of pipeline system integrity, including a summary of performance improvements, both qualitative and quantitative, to an operator's integrity management program prepared periodically.
- (6) A performance measure based on internal audits of the operator's pipeline system per 49 CFR Part 195.
- (7) A performance measure based on external audits of the operator's pipeline system per 49 CFR Part 195.
- (8) A performance measure based on operational events (for example: relief occurrences, unplanned valve closure, SCADA outages, etc.) that have the potential to adversely affect pipeline integrity.
- (9) A performance measure to demonstrate that the operator's integrity management program reduces risk over time with a focus on high risk items.

- (10) A performance measure to demonstrate that the operator's integrity management program for pipeline stations and terminals reduces risk over time with a focus on high risk items.

VI. Examples of types of records an operator must maintain.

The rule requires an operator to maintain certain records. (See §195.452(l)). This section provides examples of some records that an operator would have to maintain for inspection to comply with the requirement. This is not an exhaustive list.

- (1) a process for identifying which pipelines could affect a high consequence area and a document identifying all pipeline segments that could affect a high consequence area;
- (2) a plan for baseline assessment of the line pipe that includes each required plan element;
- (3) modifications to the baseline plan and reasons for the modification;
- (4) use of and support for an alternative practice;
- (5) a framework addressing each required element of the integrity management program, updates and changes to the initial framework and eventual program;
- (6) a process for identifying a new high consequence area and incorporating it into the baseline plan, particularly, a process for identifying population changes around a pipeline segment;
- (7) an explanation of methods selected to assess the integrity of line pipe;
- (8) a process for review of integrity assessment results and data analysis by a person qualified to evaluate the results and data;
- (9) the process and risk factors for determining the baseline assessment interval;
- (10) results of the baseline integrity assessment;
- (11) the process used for continual evaluation, and risk factors used for determining the frequency of evaluation;
- (12) process for integrating and analyzing information about the integrity of a pipeline, information and data used for the information analysis;
- (13) results of the information analyses and periodic evaluations;
- (14) the process and risk factors for establishing continual re-assessment intervals;
- (15) justification to support any variance from the required re-assessment intervals;
- (16) integrity assessment results and anomalies found, process for evaluating and remediating anomalies, criteria for remedial actions and actions taken to evaluate and remediate the anomalies;
- (17) other remedial actions planned or taken;
- (18) schedule for evaluation and remediation of anomalies, justification to support deviation from required remediation times;
- (19) risk analysis used to identify additional preventive or mitigative measures, records of preventive and mitigative actions planned or taken;
- (20) criteria for determining EFRD installation;
- (21) criteria for evaluating and modifying leak detection capability;
- (22) methods used to measure the program's effectiveness.

VII. Conditions that may impair a pipeline's integrity.

Section 195.452(h) requires an operator to evaluate and remediate all pipeline integrity issues raised by the integrity assessment or information analysis. An operator must develop a schedule that prioritizes conditions discovered on the pipeline for evaluation and remediation. The following are some examples of conditions that an operator should schedule for evaluation and remediation.

- A. Any change since the previous assessment.
- B. Mechanical damage that is located on the top side of the pipe.

- C. An anomaly abrupt in nature.
- D. An anomaly longitudinal in orientation.
- E. An anomaly over a large area.
- F. An anomaly located in or near a casing, a crossing of another pipeline, or an area with suspect cathodic protection.

[Amdt. 195-70, 65 FR 75409, Dec. 1, 2000, as amended by Amdt. 195-74, 67 FR 1661, Jan. 14, 2002; Amdt. 195-94, 75 FR 48608, Aug. 11, 2010]

Jurisdictional Tank Drawings

Jurisdictional Tank Drawings

Note: These drawings cannot be cut and pasted from the screen display. The drawings are provided as separate graphics files with the wmf extension (Windows Metafile Format) on the WinDOT CD in the folder *Drawings/Part 195*.

- [Drawing 1](#) Breakout Tankage
- [Drawing 2](#) Terminal Tankage
- [Drawing 3](#) Terminal Tankage
- [Drawing 4](#) Refinery and Refinery Piping
- [Drawing 5](#) Refinery and Refinery Piping
- [Drawing 6](#) Terminal Tankage
- [Drawing 7](#) Terminal and Breakout Tankage

Jurisdictional Tank Drawing 1

Breakout Tankage

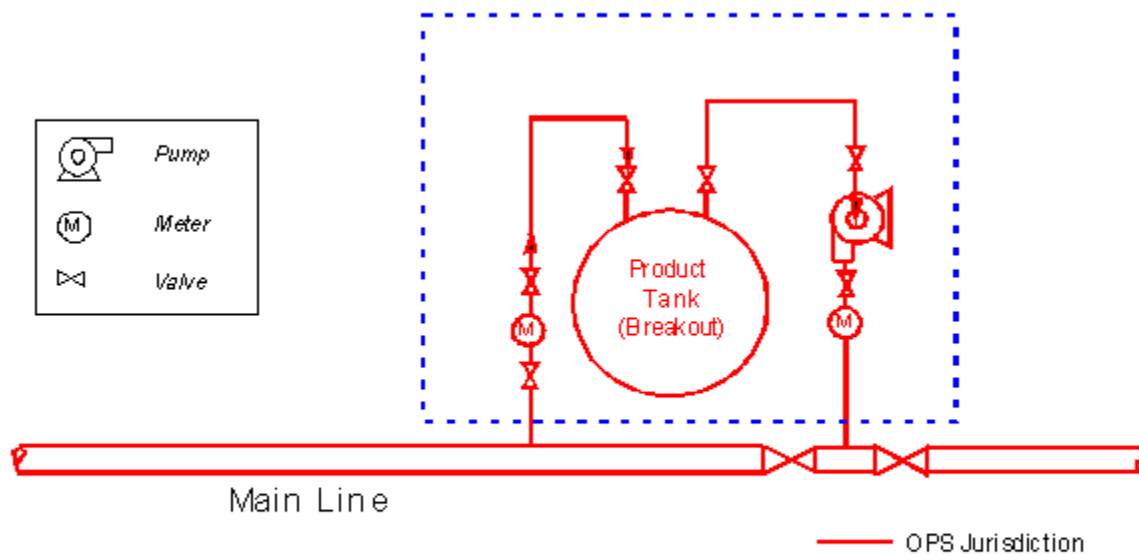

Tank 1

Jurisdictional Tank Drawing 2

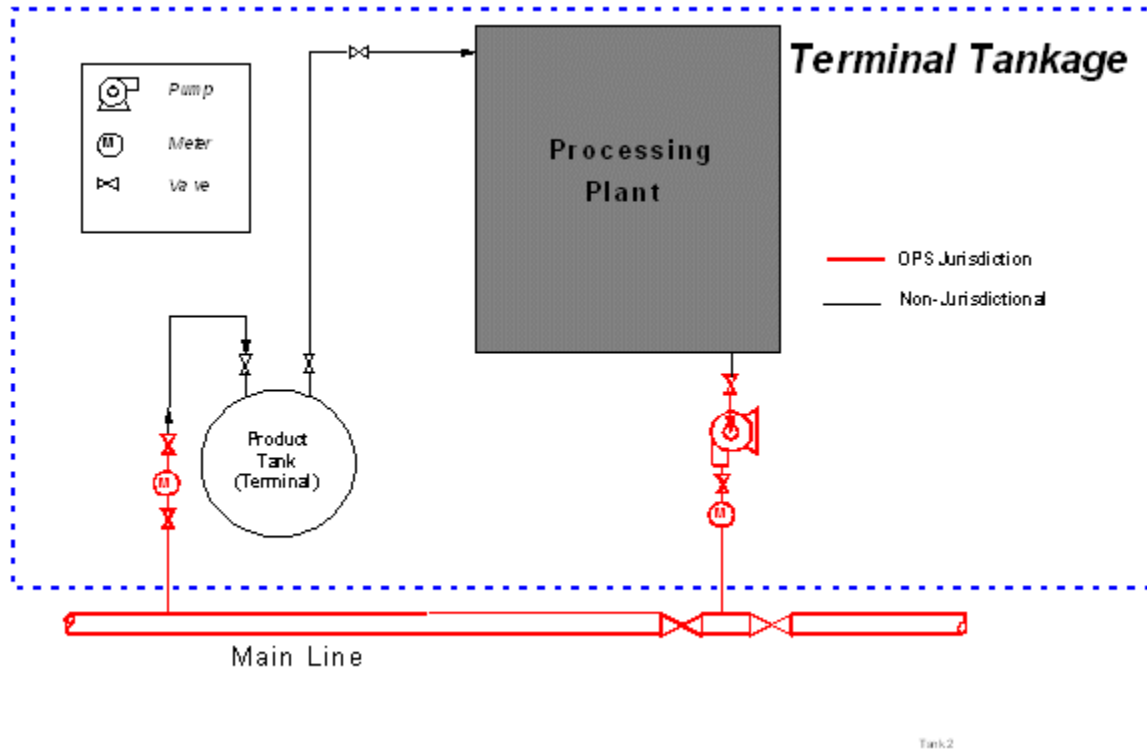

Jurisdictional Tank Drawing 3

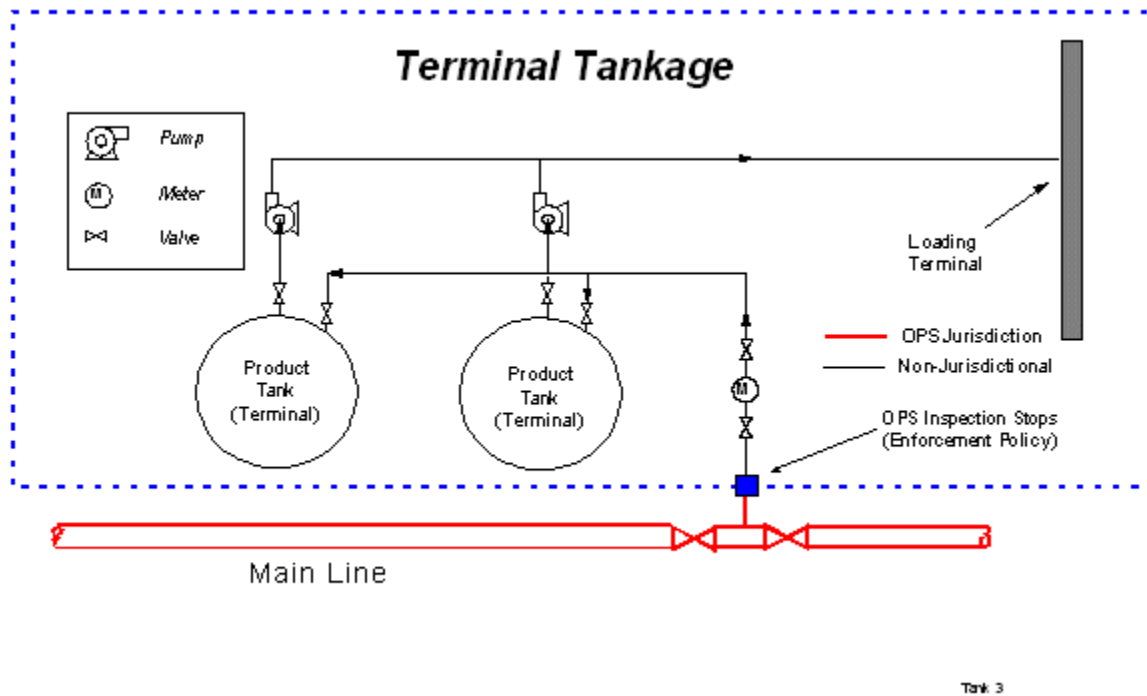

Jurisdictional Tank Drawing 5

Refinery and Refinery Piping

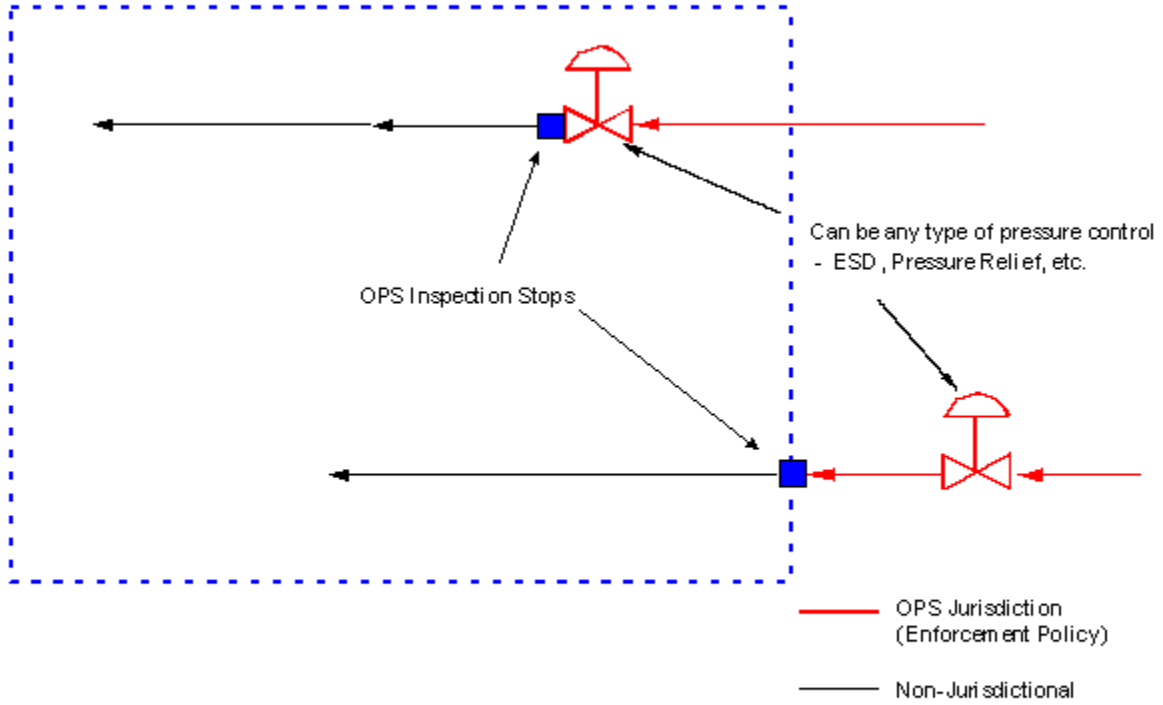

Tank 5

Jurisdictional Tank Drawing 6

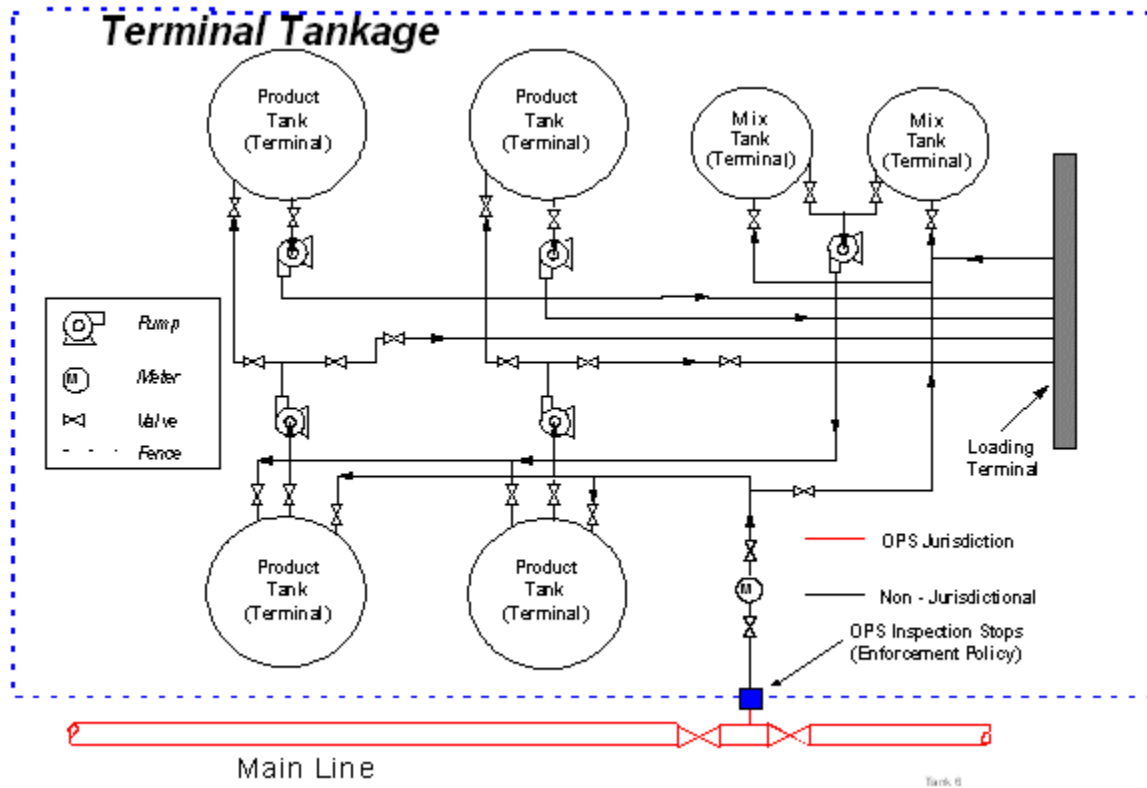

Jurisdictional Tank Drawing 7

